

SKETCH/AREA TABLE ADDENDUM

SUBJECT INFO

File No.: R96278 Parcel No.: 073W26AD13200
 Property Address: 2250 BREYMAN ST NE
 City: SALEM County: MARION State: OR ZipCode: 97301
 Owner:
 Client: Client Address:
 Appraiser Name: Inspection Date:

SKETCH

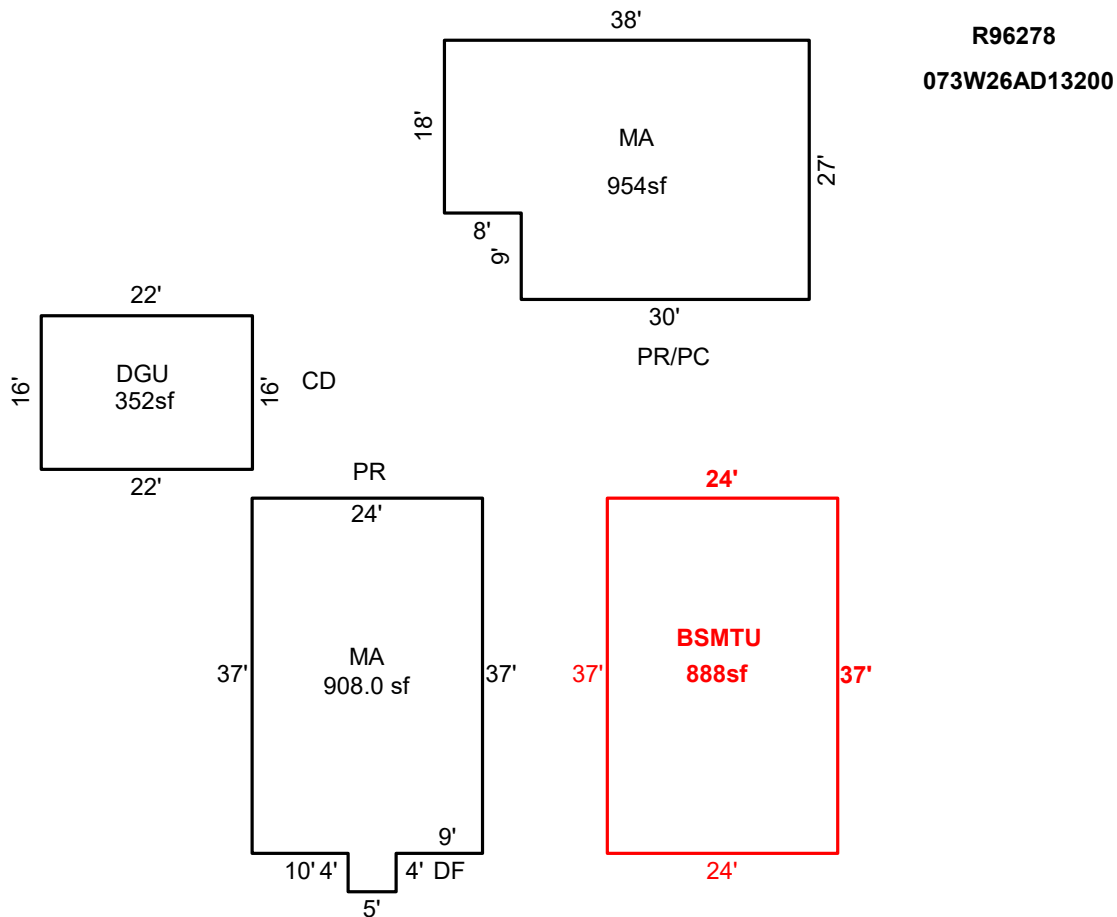

Sketch by Apex Sketch

AREA CALCULATIONS SUMMARY						COMMENT TABLE 1	
Code	Description	Factor	Net Size	Perimeter	Net Totals		
GLA1	MA	1.0	908.0	130.0		DRAWN BY KMOORE 8/8/19 UPDATED BY KMOORE 1/29/2020 updated by lk 12-3-2020 UPDATED BY CBAILEY 2/1/21	
	MA	1.0	954.0	130.0	1862.0		
BSMT	BSMTU	1.0	888.0	122.0	888.0		
GAR	DGU	1.0	352.0	76.0	352.0		
Net LIVABLE		cnt	2 (rounded)		1,862		
						COMMENT TABLE 2	COMMENT TABLE 3
						1-24-20 96 ver 10/22/20 #96 TAG NV	