

SKETCH/AREA TABLE ADDENDUM

SUBJECT INFO

File No.: R320586 Parcel No.: 042W19AD04100
 Property Address: 4236 LUCIER AV NE
 City: ST PAUL County: State: OR ZipCode: 97137
 Owner:
 Client: Client Address:
 Appraiser Name: Inspection Date:

SKETCH

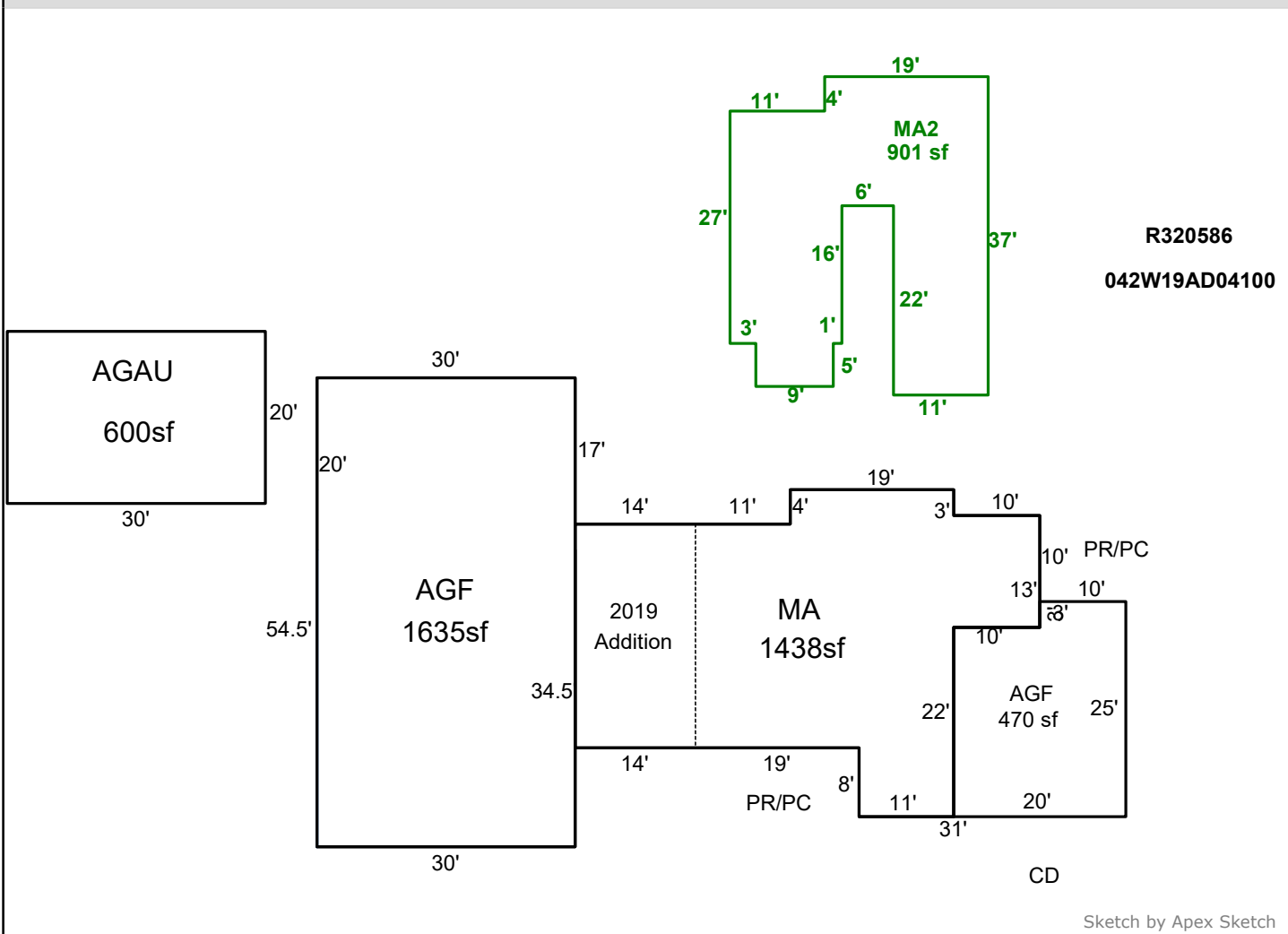

AREA CALCULATIONS SUMMARY

Code	Description	Factor	Net Size	Perimeter	Net Totals
GLA1	MA	1.0	0.0	251.0	
	MA	1.0	1437.7	184.0	1437.7
GLA2	MA2	1.0	901.0	176.0	901.0
AGF	AGF	1.0	0.0	99.0	0.0
GAR	AGF	1.0	470.0	90.0	
	AGAU	1.0	600.0	100.0	
	AGF	1.0	1635.0	169.0	2705.0

COMMENT TABLE 1

DRAWN BY PST 10/02/09
 UPDATED BY KMOORE 12/18/19
 UPDATED BY CBAILEY 12/29/20

COMMENT TABLE 2

COMMENT TABLE 3

Net LIVABLE cnt 3 (rounded) 2,339