

SKETCH/AREA TABLE ADDENDUM

SUBJECT INFO

File No.: R331509 Parcel No.: 063W34CC15300
 Property Address: 1422 HUNTER AV N
 City: KEIZER County: State: OR ZipCode: 97303
 Owner:
 Client: Client Address:
 Appraiser Name: Inspection Date:

SKETCH

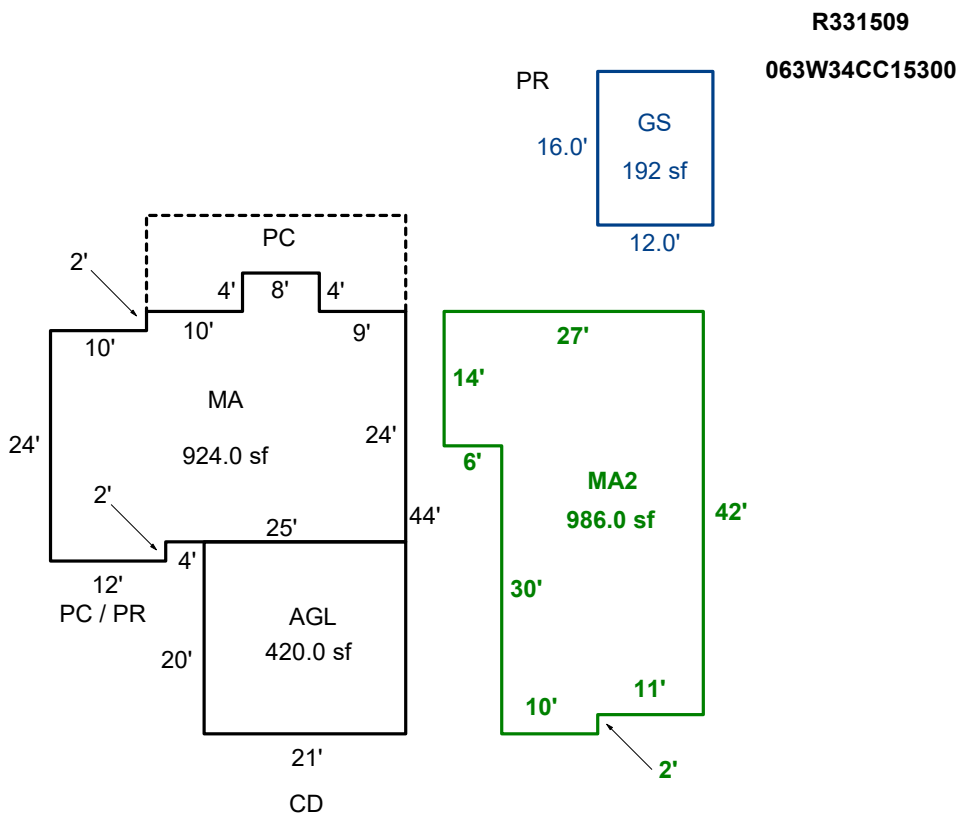

Sketch by Apex Sketch

AREA CALCULATIONS SUMMARY

Code	Description	Factor	Net Size	Perimeter	Net Totals
GBA1	GS	1.0	192.0	56.0	192.0
GLA1	MA	1.0	924.0	134.0	924.0
GLA2	MA2	1.0	986.0	142.0	986.0
GARAGE	AGL	1.0	420.0	82.0	420.0

COMMENT TABLE 1

APEX BY MJB 05-27-11
 UPDATED BY CBAILEY 2/2/21

COMMENT TABLE 2

6/20/18 #96 CYCLE NV
 1/22/21 #24 TAG VER GS

COMMENT TABLE 3

Net LIVABLE cnt 2 (rounded) 1,910
 Net BUILDING cnt 1 (rounded) 192