

Acct ID: 523460 MTL: 072W20D002900 Date: **3/27/24** Appr: **MLH** Prop Class: 551 RMV Prop Class: 451
 Situs: 1190 CORDON RD NE SALEM OR 97317 MaSaNh: 03 06 000 Unit: 40921 Year: 2024



Last Date Appraised: 01/23/2024 Appraiser: MATTHEW HAMILTON Retag: Y N Tag info: 2024 - Tags/Permit (Alt Energy System)

Owner: PANIAGUA, SERGIO Roll Type: R

Cycle Tag **Sales Verification** Other: _____ Inspection level: 1 2 3 **4** LCB TTO INSP AV: 276363

RMV Land: 289980 RMV Imp: 345980 RMV Total: 635960 MAV: 204430 MSAV: 71933 SAV: 140169

Comment: 24-25: L3 01.23.24 GRH
 23-24 L4 05.08.23 WW

No Listing Sales code 7 **Data entry error on previous deed entry** INPUT MLH 3/29/24
 or 21 (new solar after sale) **update inventory**

RP/MS	Code	Description	2022
RP	ZONED	FARM EFU ZONED	

OSDs

Count	Code	Description	RMV	Code Area	Exception
1	SAA	SA OSD - AVERAGE	45000	92410	0

Land

Site: 2	Code Area: 92410	Size: 1.00 Acres	Use Code: 005	Zone: REST	SAV Use: 011	Exception: 0
Class: 2BD	Value Source: Farm Homesite	Description: TWO BENCH DRY	RMV: 133870	Exception: Y N		
Adjustment(s): GSOIL	Fire Patrol:	Description:				
Comments: Liability year - 2009 / 2400210						
Site: 3	Code Area: 92410	Size: 0.83 Acres	Use Code: 005	Zone: REST	SAV Use: 011	Exception: 0
Class: 2BD	Value Source: Farm Use - EFU	Description: TWO BENCH DRY	RMV: 111110	Exception: Y N		
Adjustment(s): GSOIL	Fire Patrol:	Description:				
Comments: Liability year - 1986 / 2400210						

Improvements - Residence / Manufactured Structures

Bldg: 1	Code Area: 92410	Stat Class: 142 -	Year Blt: 1948	Eff Year Blt: 1993	Sq.Ft: 2232	% Complete: 100
Desc: Multi Story above grade	Dimensions:	RMV: 264960				
Func Obsc: 100	Econ %: 100	Other %: 100	Exception: 0	Adjust:	Adjust RMV: 0	

Floors

Type	Class	Display Group	Floor Size	Beds	Baths	Yr Blt	Eff Yr Blt	Inventory	Exception
First Floor	4 -	Finished	1488	2	FB-2	1948	1993	BATH - 2, HVAC+, FP - 1, KIT+, ROOF	Y N
Attic	4 -	Finished	744	2	0	1948	1993	HVAC+	Y N

Accessories

Description	Class	Size SqFt	Eff Yr Blt	RMV	Quantity	Exception
YARD IMPROVEMENTS GOOD	4	1	1993	31620	1	Y N

Bldg: 4	Code Area: 92410	Stat Class: 138	Year Blt: 2003	Eff Year Blt: 2003	Sq.Ft: 0	% Complete: 100
Desc: Res other improvements	Dimensions:	RMV: 56370				
Func Obsc: 100	Econ %: 100	Other %: 100	Exception: 0	Adjust:	Adjust RMV: 0	

Floors

Type	Class	Display Group	Floor Size	Beds	Baths	Yr Blt	Eff Yr Blt	Inventory	Exception
Garage Oversized Detached	3	Unfinished	1260	0	0	2003	2003	ROOF	Y N

Accessories

Description	Class	Size SqFt	Eff Yr Blt	RMV	Quantity
No accessory data available					

Improvements - Accessory Buildings

Bldg: 2	Code Area: 92410	Stat Class: 341	Year Blt: 1992	Eff Year Blt: 1992	Sq.Ft: 96	% Complete: 100
Desc: Multi Purpose Shed (MP)	Dimensions: 12x8	RMV: 150				
Func Obsc: 100	Econ %: 100	Other %: 100	Exception: 0	Adjust:	Adjust RMV: 0	

Floors

Type	Class	Display Group	Floor Size	Beds	Baths	Yr Blt	Eff Yr Blt	Inventory	Exception
Multi-Purpose Bldg	4	Finished	96	0	0	1992	1992	FAIR	Y N

Accessories

Description	Class	Size SqFt	Eff Yr Blt	RMV	Quantity
No accessory data available					

50 under 100sf

Bldg: 3 Code Area: 92410 Stat Class: 351 Year Blt: 1992 Eff Year Blt: 1992 Sq.Ft: 728 % Complete: 100
 Desc: General Purpose Building (GB) Dimensions: 52x14 RMV: 4500
 Func Obsc: 100 Econ %: 100 Other %: 100 Exception: 0 Adjust: Adjust RMV: 0

1993

Has been this way

I/O

Floors

Type	Class	Display Group	Floor Size	Beds	Baths	Yr Blt	Eff Yr Blt	Inventory
General Purpose Bldg	4	Finished	728	0	0	1992	1992	FAIR

Accessories

Description	Class	Size SqFt	Eff Yr Blt	RMV	Quantity
No accessory data available					

Bldg: 5 Code Area: 92410 Stat Class: 905 Year Blt: 2023 Eff Year Blt: 2023 Sq.Ft: 0 % Complete: 100
 Desc: Rural Solar Panel/Array Dimensions: RMV: 20000
 Func Obsc: 100 Econ %: 100 Other %: 100 Exception: 0 Adjust: Adjust RMV: 0

N/C

Floors

Type	Class	Display Group	Floor Size	Beds	Baths	Yr Blt	Eff Yr Blt	Inventory
No floor data available								

Accessories

Description	Class	Size SqFt	Eff Yr Blt	RMV	Quantity
No accessory data available					

SKETCH/AREA TABLE ADDENDUM

SUBJECT INFO

File No.: 523460 Parcel No.: 072W20D 02900
 Property Address: 1190 CORDON RD NE
 City: SALEM County: MARION State: OR ZipCode: 97317
 Owner:
 Client: Client Address:
 Appraiser Name: Inspection Date:

SKETCH

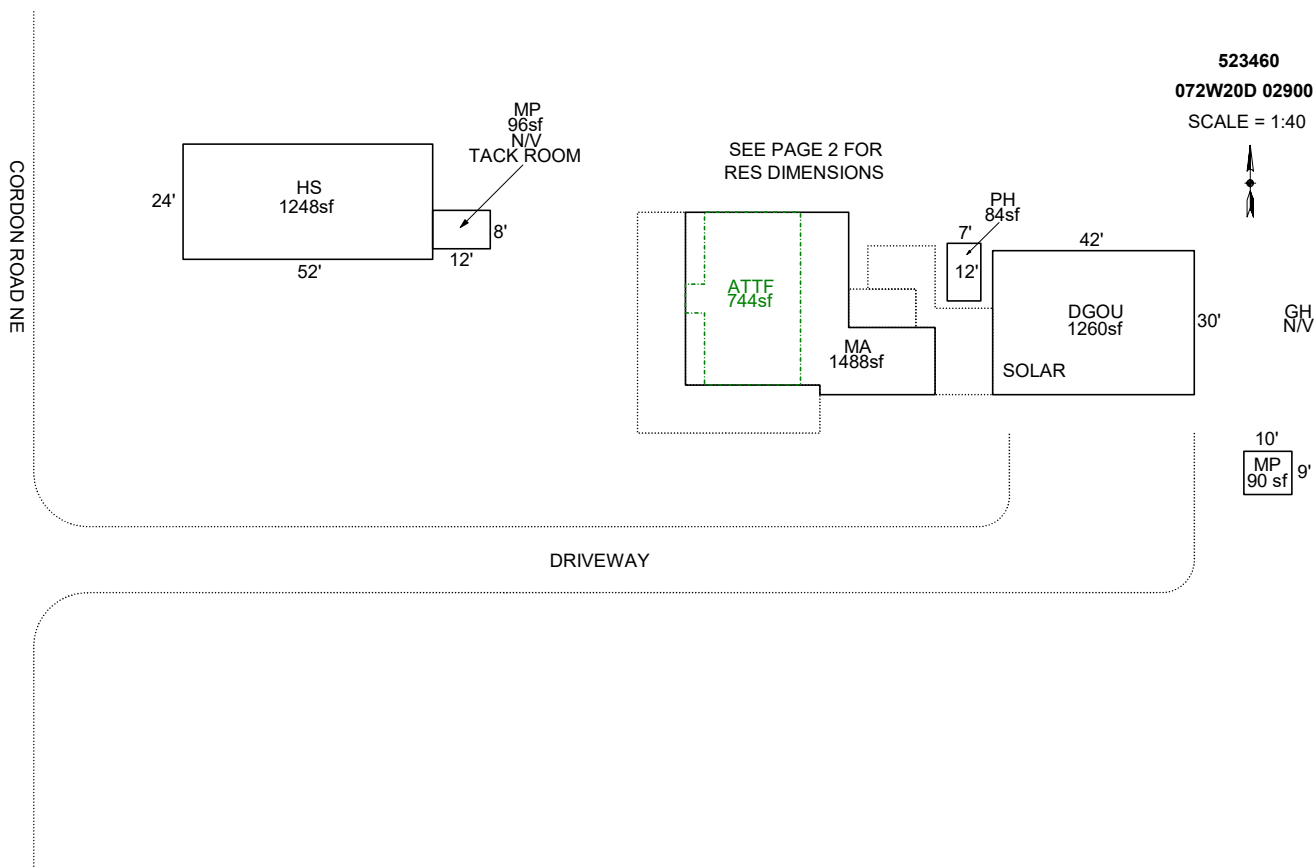

Sketch by Apex Sketch

AREA CALCULATIONS SUMMARY						COMMENT TABLE 1			
Code	Description	Factor	Net Size	Perimeter	Net Totals				
GBA1	MP	1.0	90.0	38.0		APEX BY CW 11/6/17 UPDATED BY WW 05/08/23 UPDATED BY CJURAN 08/28/2023 555-23-005310 UPDATED BY CJURAN 02/08/2024 UPLOADED BY CJURAN 03/27/2024			
	PH	1.0	84.0	38.0					
	HS	1.0	1248.0	152.0					
	MP	1.0	96.0	40.0	1518.0				
GLA1	MA	1.0	1488.0	180.0	1488.0				
GLA2	ATTF	1.0	744.0	120.0	744.0				
DW	PR/DW	1.0	740.0	168.0					
	PR/DF	1.0	112.0	44.0	852.0				
GAR	DGOU	1.0	1260.0	144.0	1260.0				
PC	PC	1.0	374.0	114.0	374.0	COMMENT TABLE 2	COMMENT TABLE 3		
						WW 05.08.23 GRH 01/23/2024 MLH 03/27/2024	SV L4 TAGS L3 SV L4		
	Net LIVABLE	cnt	2 (rounded)		2,232				
	Net BUILDING	cnt	4 (rounded)		1,518				

SKETCH/AREA TABLE ADDENDUM

SUBJECT INFO

File No.: 523460 Parcel No.: 072W20D 02900
 Property Address: 1190 CORDON RD NE
 City: SALEM County: MARION State: OR ZipCode: 97317
 Owner:
 Client: Client Address:
 Appraiser Name: Inspection Date:

SKETCH

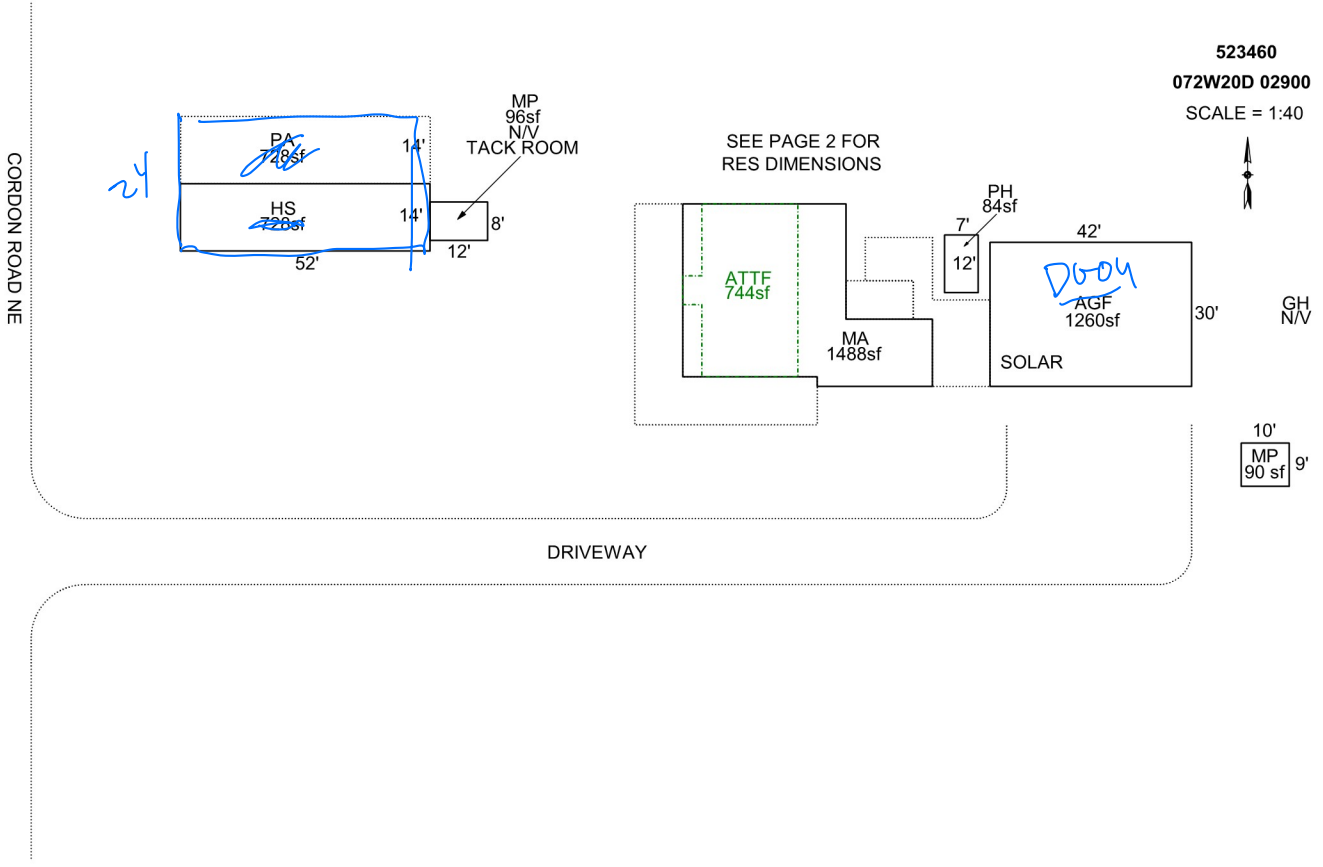

AREA CALCULATIONS SUMMARY

Code	Description	Factor	Net Size	Perimeter	Net Totals
GBA1	MP	1.0	90.0	38.0	
	PH	1.0	84.0	38.0	
	HS	1.0	728.0	132.0	
	MP	1.0	96.0	40.0	998.0
GLA1	MA	1.0	1488.0	180.0	1488.0
GLA2	ATTF	1.0	744.0	120.0	744.0
DW	PR/DW	1.0	740.0	168.0	
	PR/DF	1.0	112.0	44.0	
	PA	1.0	728.0	132.0	1580.0
GAR	AGF	1.0	1260.0	144.0	1260.0
PC	PC	1.0	374.0	114.0	374.0
	Net LIVABLE	cnt	2 (rounded)		2,232
	Net BUILDING	cnt	4 (rounded)		998

COMMENT TABLE 1

APEX BY CW 11/6/17
 UPDATED BY WW 05/08/23
 UPDATED BY CJURAN 08/28/2023 555-23-005310
 UPDATED BY CJURAN 02/08/2024

COMMENT TABLE 2

WW 05.08.23
 GRH 01/23/2024

3/27/24 MLH

COMMENT TABLE 3

SV L4
 TAGS L3

SV 24

SKETCH/AREA TABLE ADDENDUM

SUBJECT INFO

File No.: 523460 Parcel No.: 072W20D 02900
 Property Address: 1190 CORDON RD NE
 City: SALEM County: MARION State: OR ZipCode: 97317
 Owner:
 Client: Client Address:
 Appraiser Name: Inspection Date:

SKETCH

523460
072W20D 02900
 SCALE = 1:20

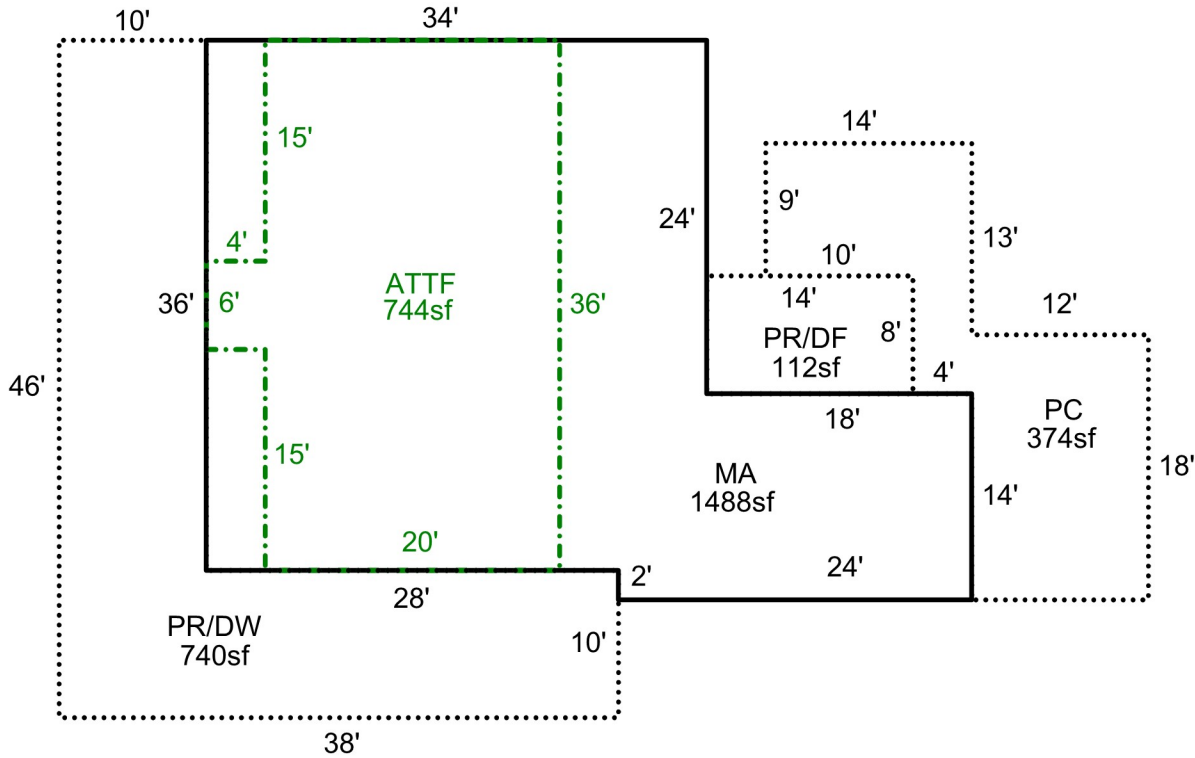

Sketch by Apex Sketch

AREA CALCULATIONS SUMMARY

Code	Description	Factor	Net Size	Perimeter	Net Totals
GLA1	MA	1.0	1488.0	180.0	1488.0
GLA2	ATTF	1.0	744.0	120.0	744.0
DW	PR/DW	1.0	740.0	168.0	
	PR/DF	1.0	112.0	44.0	852.0
PC	PC	1.0	374.0	114.0	374.0

COMMENT TABLE 1

APEX BY CW 11/6/17
 UPDATED BY WW 05/08/23
 UPDATED BY CJURAN 08/28/2023 555-23-005310
 UPDATED BY CJURAN 02/08/2024

COMMENT TABLE 2

WW 05.08.23
 GRH 01/23/2024

COMMENT TABLE 3

SV L4
 TAGS L3

Net LIVABLE cnt 2 (rounded) 2,232

R23460
072W20D 02900
See Page 2 for Res Dimensions

Scale=1:50



GH
N/V
10'
MP
90 sf 9'

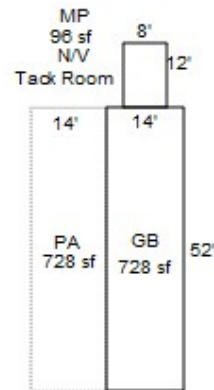
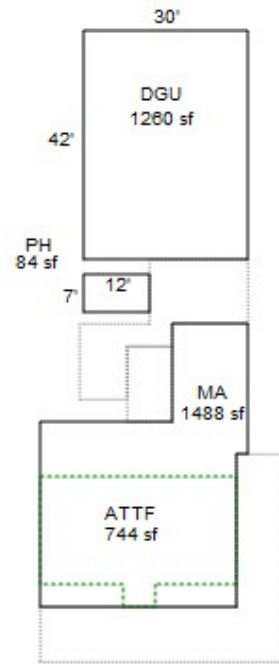

R23460
072W20D 02900
See Page 1 for All Bldgs

Scale=1:20

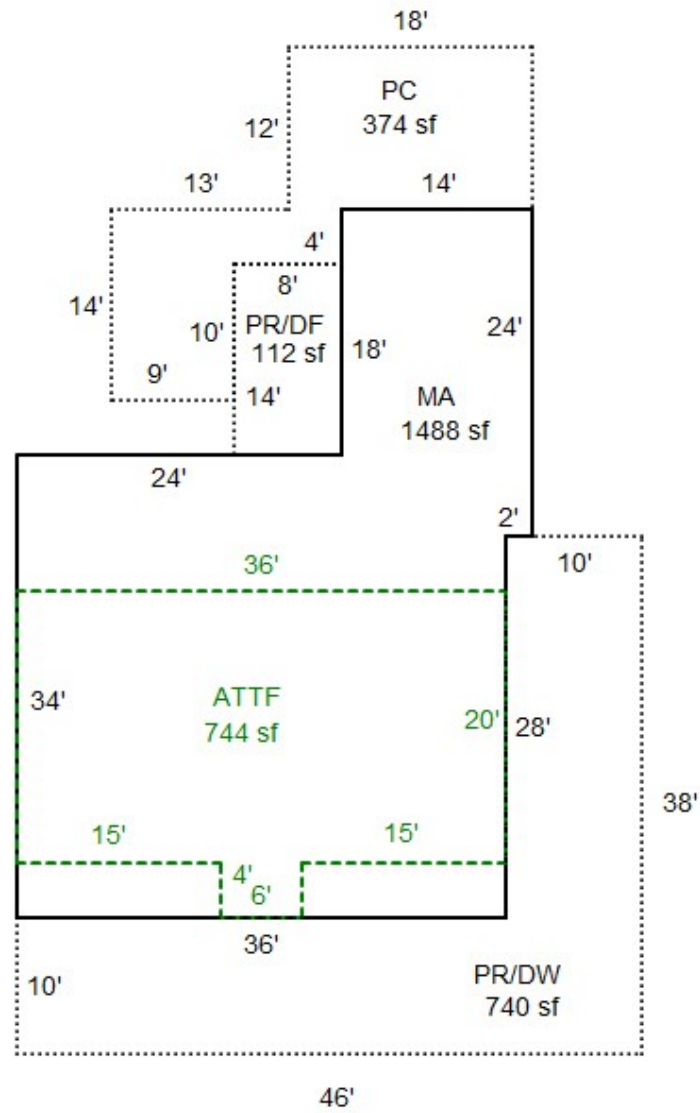

SKETCH/AREA TABLE ADDENDUM

SUBJECT INFO

File No.: 523460 Parcel No.: 072W20D 02900
 Property Address: 1190 CORDON RD NE
 City: SALEM County: MARION State: OR ZipCode: 97317
 Owner:
 Client: Client Address:
 Appraiser Name: Inspection Date:

SKETCH

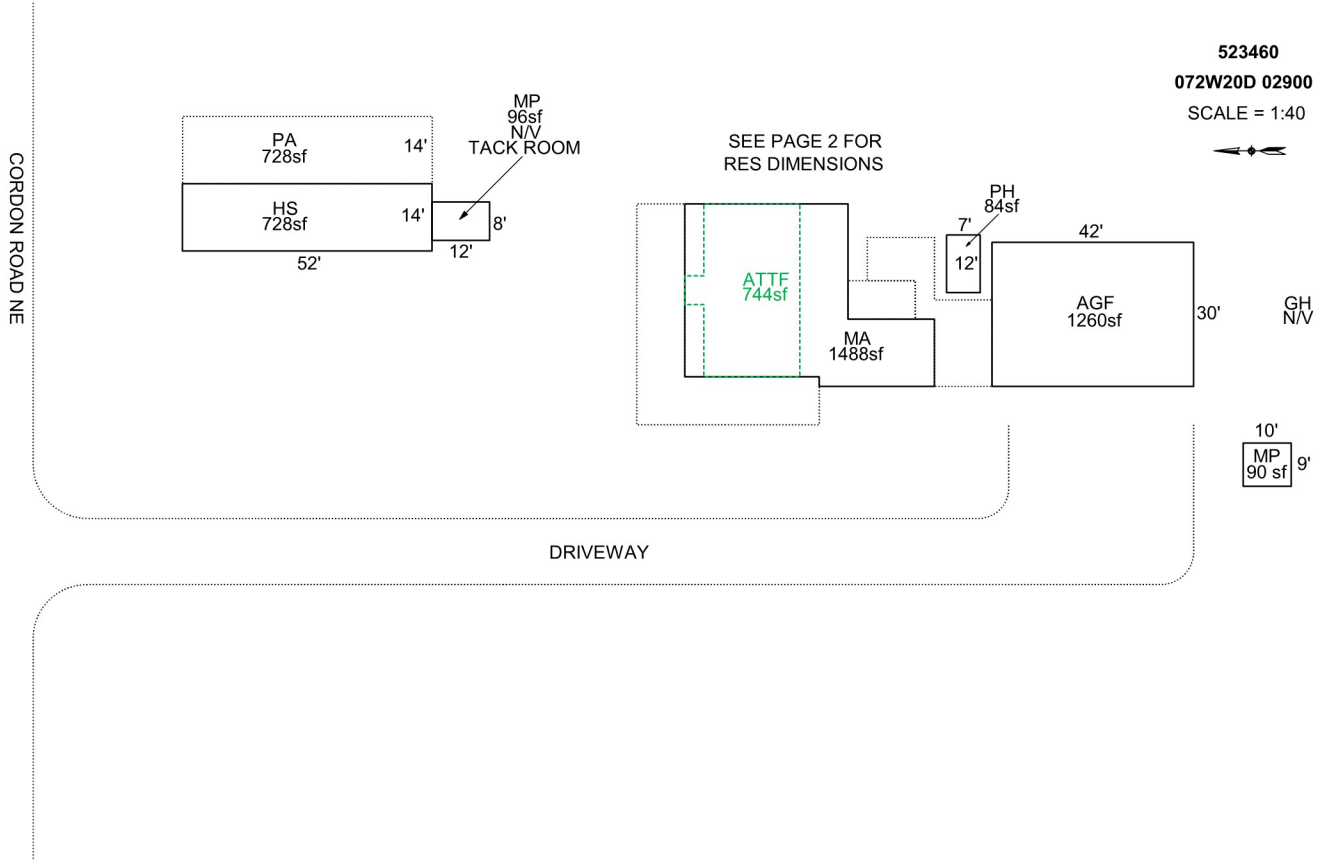

Sketch by Apex Sketch

AREA CALCULATIONS SUMMARY

COMMENT TABLE 1

Code	Description	Factor	Net Size	Perimeter	Net Totals
GBA1	MP	1.0	90.0	38.0	
	PH	1.0	84.0	38.0	
	HS	1.0	728.0	132.0	
	MP	1.0	96.0	40.0	998.0
GLA1	MA	1.0	1488.0	180.0	1488.0
GLA2	ATTF	1.0	744.0	120.0	744.0
DW	PR/DW	1.0	740.0	168.0	
	PR/DF	1.0	112.0	44.0	
	PA	1.0	728.0	132.0	1580.0
GAR	AGF	1.0	1260.0	144.0	1260.0
PC	PC	1.0	374.0	114.0	374.0

APEX BY CW 11/6/17
 UPDATED BY WW 05/08/23
 UPDATED BY CJURAN 08/28/2023 555-23-005310

COMMENT TABLE 2

COMMENT TABLE 3

WW 05.08.23

SV L4

Net LIVABLE cnt 2 (rounded) 2,232
 Net BUILDING cnt 4 (rounded) 998

SKETCH/AREA TABLE ADDENDUM

SUBJECT INFO

File No.: 523460 Parcel No.: 072W20D 02900
 Property Address: 1190 CORDON RD NE
 City: SALEM County: MARION State: OR ZipCode: 97317
 Owner:
 Client: Client Address:
 Appraiser Name: Inspection Date:

SKETCH

523460
072W20D 02900
 SCALE = 1:20

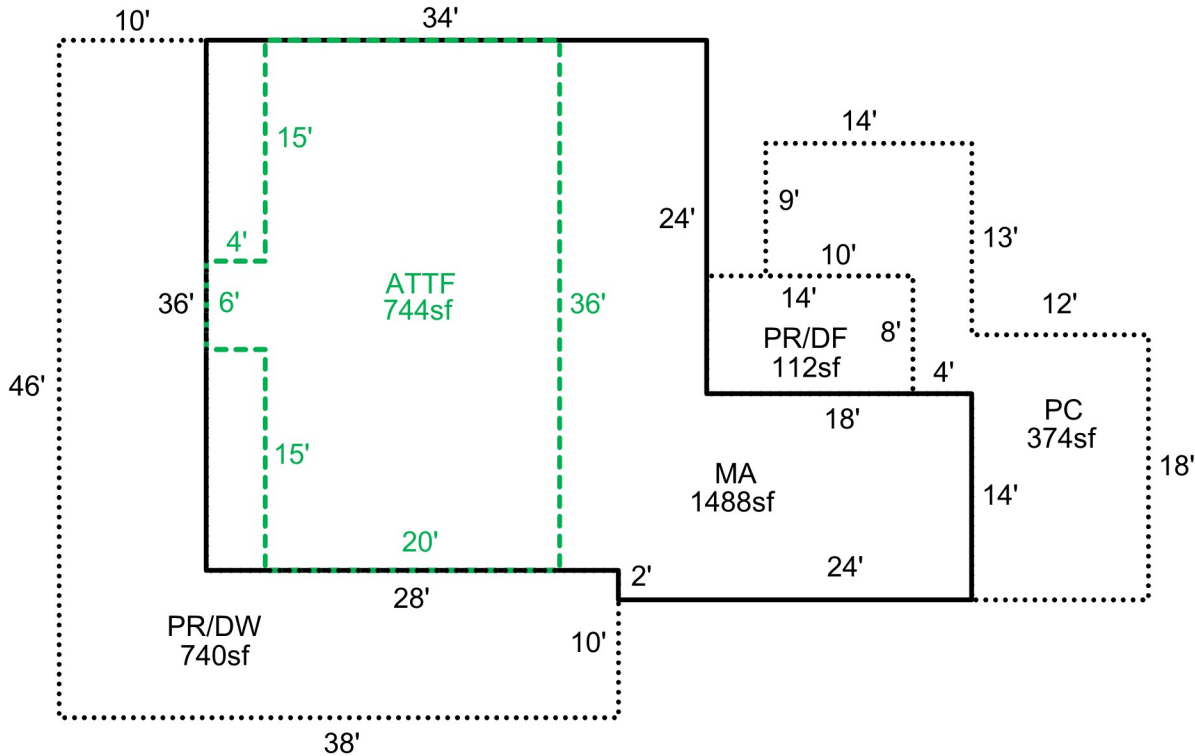

Sketch by Apex Sketch

AREA CALCULATIONS SUMMARY

Code	Description	Factor	Net Size	Perimeter	Net Totals
GLA1	MA	1.0	1488.0	180.0	1488.0
GLA2	ATTF	1.0	744.0	120.0	744.0
DW	PR/DW	1.0	740.0	168.0	
	PR/DF	1.0	112.0	44.0	852.0
PC	PC	1.0	374.0	114.0	374.0

COMMENT TABLE 1

APEX BY CW 11/6/17
 UPDATED BY WW 05/08/23
 UPDATED BY CJURAN 08/28/2023 555-23-005310

COMMENT TABLE 2

WW 05.08.23

COMMENT TABLE 3

SV L4

Net LIVABLE cnt 2 (rounded) 2,232

072W20D 02900

R23460

1190 CORDON RD NE
SALEM, OR 97317

BUILDING DIAGRAM AND OUTBUILDINGS

CAND 10F2

ACCT NO: ~~51745-000~~ R23460

MAP NO: 72W20D

TAX LOT: 2900

11-5-03
8-10-04-05
GONE
MP-5

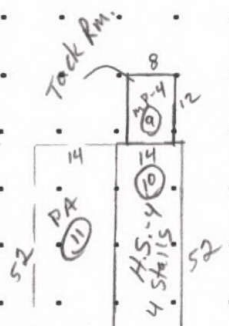
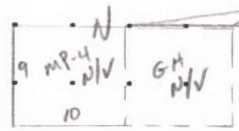
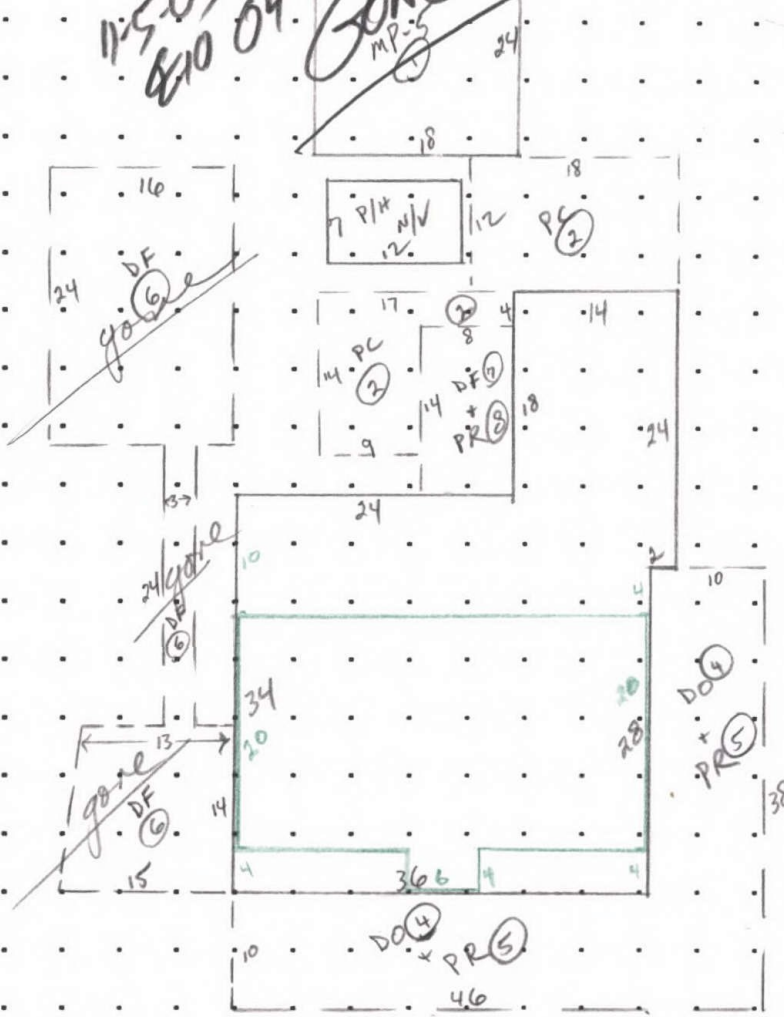

CALCULATIONS:

House
 $34 \times 36 = 1224$
 $14 \times 18 = 252$
 $2 \times 6 = 12$
1488

Fin. Attic
 $20 \times 36 = 720$
 $4 \times 6 = 24$
744

SCALE: 1" = 20'

MEASUREMENT VERIFIED

YR BLT: 1948

ADDRESS: 1190 Cordon Rd. N.E.

SALES Date Amt.

DATE
10-27-93

BY
DK #87

REMARKS:
Est. Remodel 1991
At least Kitchen.

BUILDER: Sa Cm, 97301

6. 21.04
11-7-12

Royce
19/20

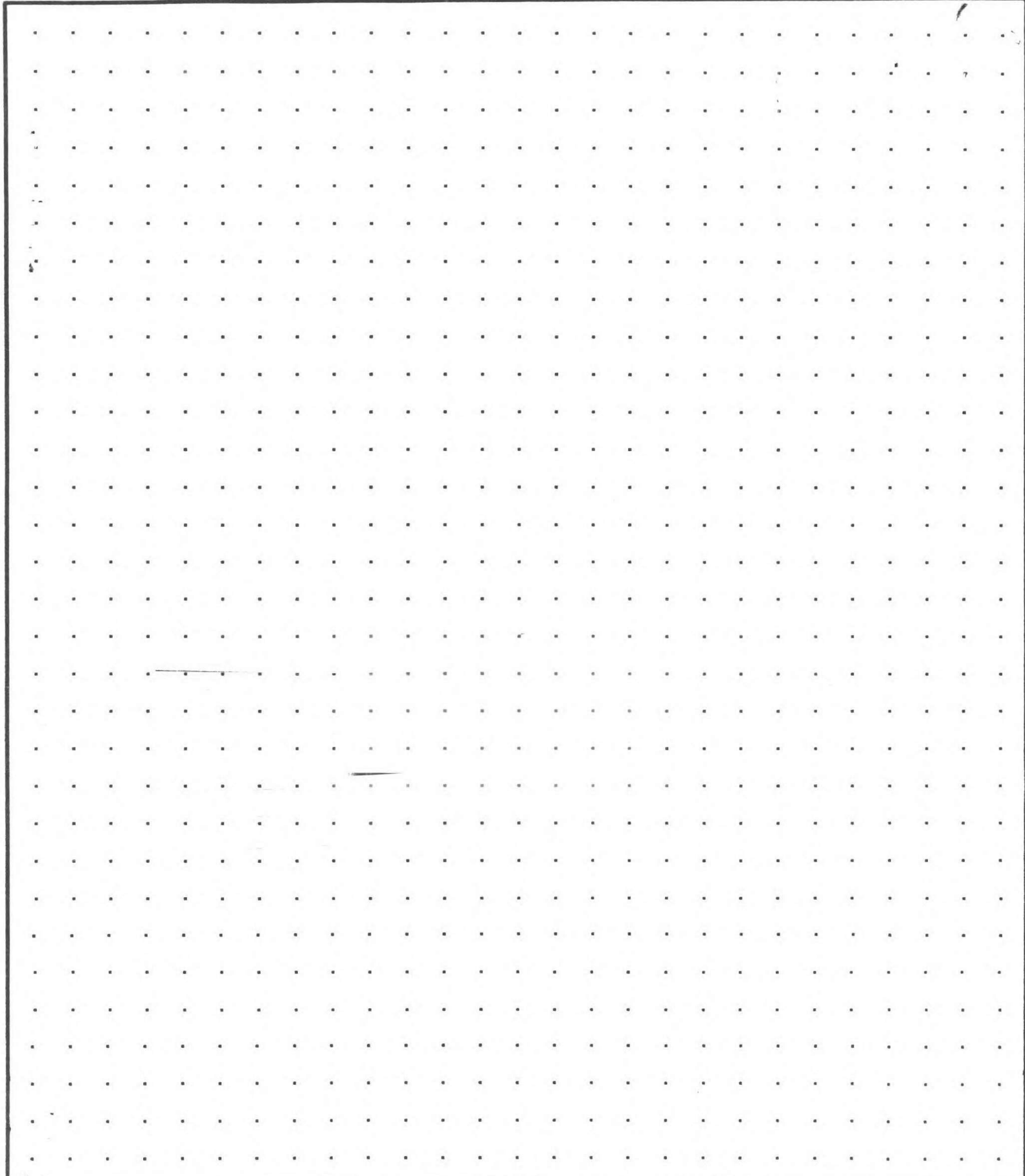

CALCULATIONS:

SCALE: 1" = 20'

BUILDING DIAGRAM AND OUTBUILDINGS

ACCT NO: R23460

MAP NO: 72W 20D

TAX LOT: 02900

Card 2 of 2



GRAVEL DRIVE

HOUSE

CALCULATIONS:

SCALE: 1" = 20'

MEASUREMENT VERIFIED		YR BLT:	ADDRESS: 1190 CORDON RD NE	SALES	
DATE	BY	BUILDER:		Date	Amt.
11-5-03 11-7-12	EIO 19 Jul			REMARKS:	

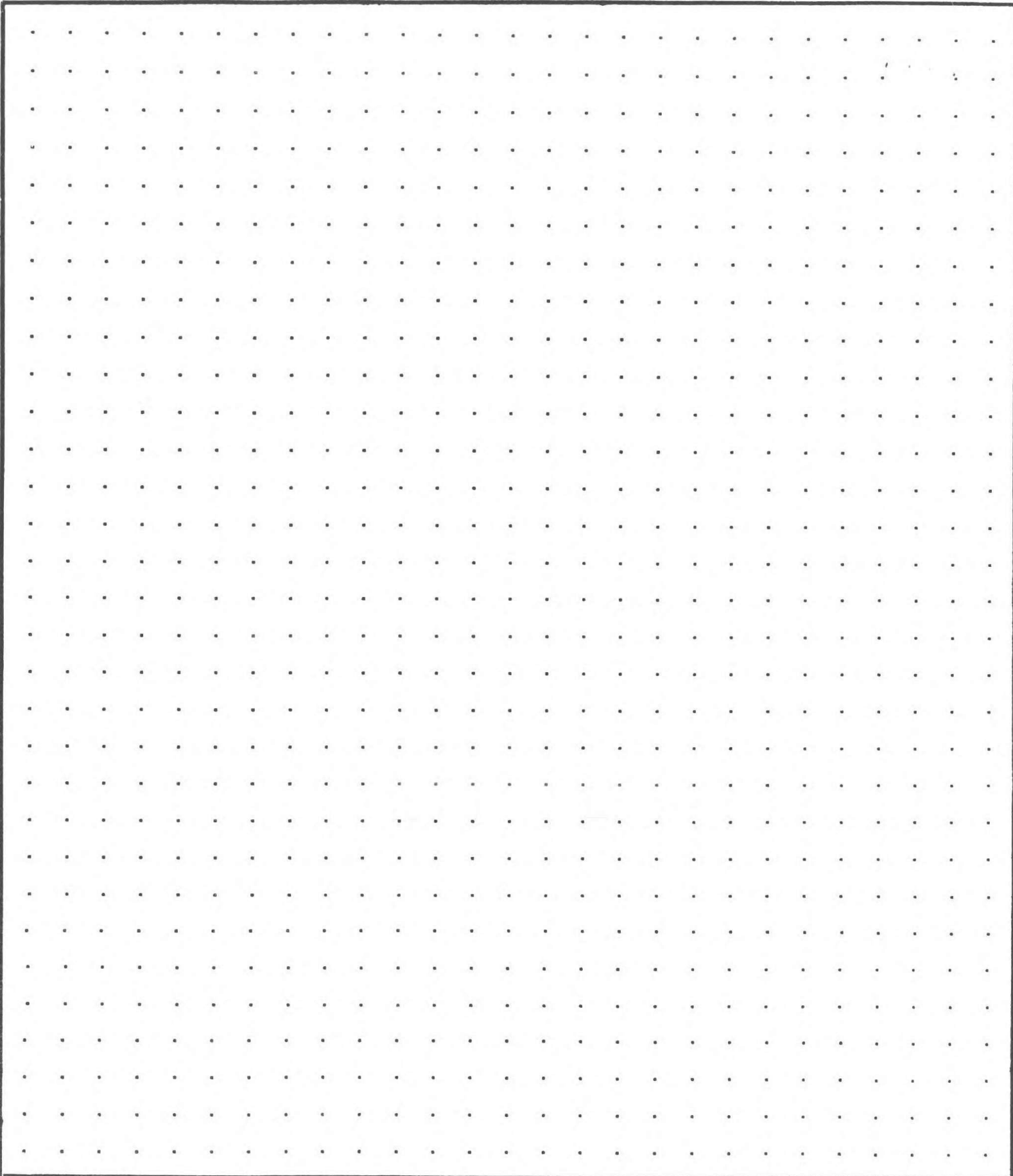

CALCULATIONS:

SCALE: 1" = 20'

SKETCH/AREA TABLE ADDENDUM

Parcel No 072W20D 02900

File No R23460

SUBJECT	Property Address 1190 CORDON RD NE		
	City SALEM	County MARION	State OR
	Owner		
	Client		
	Appraiser Name		

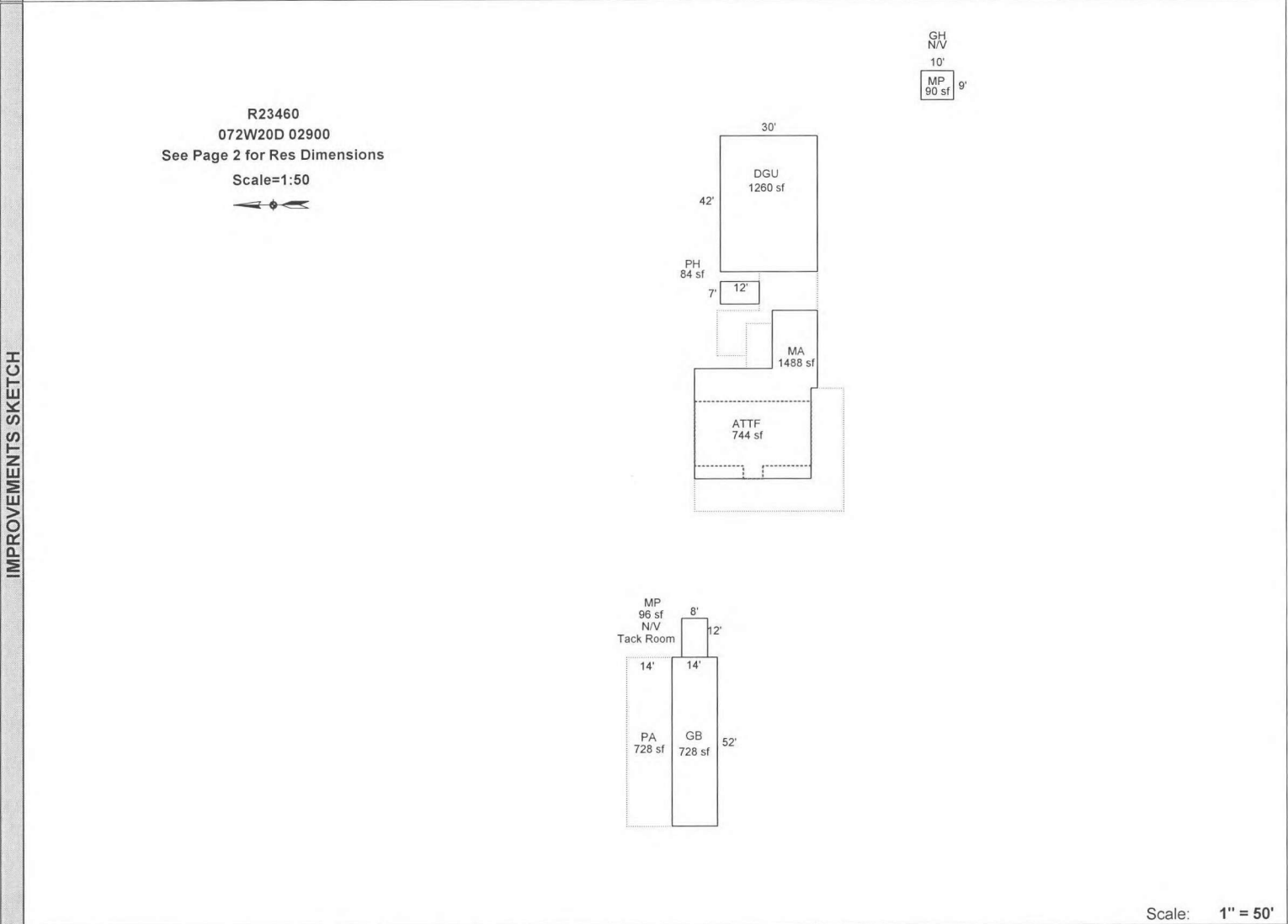

AREA CALCULATIONS	AREA CALCULATIONS SUMMARY						Comment Table 1	
	Code	Description	Factor	Net Size	Perimeter	Net Totals	APEX BY CW 11/6/17 <div style="display: flex; justify-content: space-between;"> <div style="width: 45%; border: 1px solid black; height: 100px;"></div> <div style="width: 45%; border: 1px solid black; height: 100px;"></div> </div>	
	GLA1	MA	1.00	1488	180	1488		
	GLA2	ATTF	1.00	744	120	744		
	GBA1	PH	1.00	84	38			
		MP	1.00	90	38			
		HS	1.00	728	132			
		MP	1.00	96	40	998		
	GAR	AGF	1.00	1260	144	1260		
	DW	PR/DW	1.00	740	168			
PR/DF		1.00	112	44				
	PA	1.00	728	132	1580			
PC	PC	1.00	374	114	374			
	Net LIVABLE Area		(rounded w/ factors)		2232			
	Net BUILDING Area		(rounded w/ factors)		998			

SKETCH/AREA TABLE ADDENDUM

Parcel No 072W20D 02900

File No R23460

Property Address 1190 CORDON RD NE

City SALEM

County MARION

State OR

Zip 97317

Owner

Client

Appraiser Name

SUBJECT

IMPROVEMENTS SKETCH

R23460
072W20D 02900
See Page 1 for All Bldgs
Scale=1:20

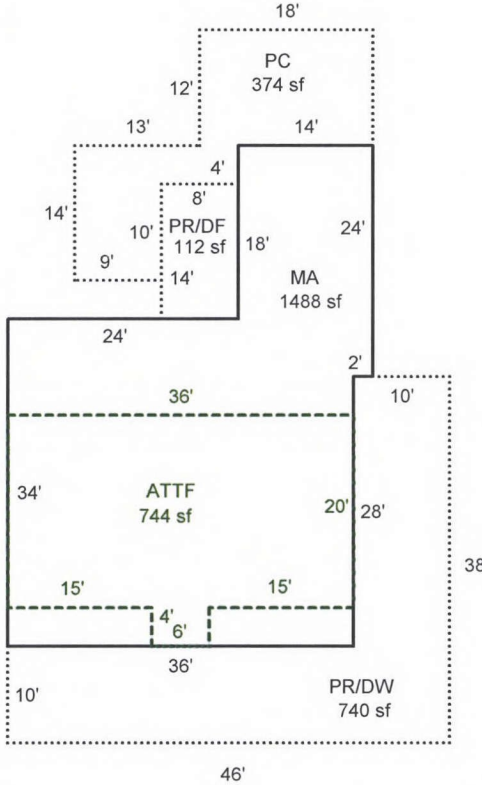

Scale: 1" = 20'

AREA CALCULATIONS

AREA CALCULATIONS SUMMARY

Code	Description	Factor	Net Size	Perimeter	Net Totals
GLA1	MA	1.00	1488	180	1488
GLA2	ATTF	1.00	744	120	744
DW	PR/DW	1.00	740	168	
	PR/DF	1.00	112	44	852
PC	PC	1.00	374	114	374
Net LIVABLE Area (rounded w/ factors)					2232

Comment Table 1

APEX BY CW 11/6/17

Comment Table 2

Comment Table 3

R23460 072W20D 02900 Appr #: 19 Date 11-7-12 Prop Class 551 Prop Code A23
 Situs Address 1190 CORDON RD NE Franchise Code 19 Year For: 2012-2013
 Owner CUANAS,ALEJANDRO &

Tags Cycle Sales Verification Other: _____

Notes: _____

RMV Land: **146,670** RMV Imp: **126,540** RMV Total: **273,210** M50 Total: **170,680**
 Seg.Type MA Seg. # **1.1** Method: R05 Class 3 Area 1488 Eff Area 1488
 Length Width Roof Cover COMP Plumbing BATH1.5 Heat FA
 Fireplace SGL-P Inter. Comp: DW;H&F;DSP, *Rng* Bedrooms 2
 Year Built 1948 Eff. Year Built 1948 Cond. P F A G E
 Adj Codes RLCM3;R3+QLTY Qty ___ % Comp ___ Func ___ Econ ___ RMV: 57,030
 Lump Sum _____ Except Code/Year _____ Comments _____

Seg.Type ATTF Seg. # **1.2** Method: R05 Class 3 Area 744 Eff Area 744
 Length Width Roof Cover Plumbing *None* Heat FA
 Fireplace Inter. Comp: Bedrooms 2
 Year Built 1948 Eff. Year Built 1948 Cond. P F A G E
 Adj Codes RLCM3;R3+QLTY Qty ___ % Comp ___ Func ___ Econ ___ RMV: 20,420
 Lump Sum _____ Except Code/Year _____ Comments _____

Accessory Improvements

Seg.Type YI3G Seg. # **1.3** Method: R05 Class Area 1 Eff Area 1
 Length Width Foundation Ex. Wall Roof Cover
 Roof Style Floor Plumbing
 Year Built Eff. Year Built: Cond. P F A G E % Comp ___ Econ ___ RMV: 5,000
 Lump Sum _____ Except Code/Year _____ Comments _____

Out Buildings

Seg.Type MP Seg. # **2.1** Method: F;N Class 4 Area 96 Eff Area 96
 Length 12 Width 8 Foundation POST Ex. Wall PLYWD Roof Cover COMP
 Roof Style GABLE Floor DIRT Plumbing
 Heat Int. Comp. Elect. Yr. Blt. 1992 Eff. Yr. Blt: 1992
 Cond. P F A G E Adj. Codes FLCM % Comp ___ Func ___ Econ ___ RMV: 0
 Lump Sum _____ Except Code/Year _____ Comments _____

Seg.Type *HS GB* Seg. # **3.1** Method: F09 Class 4 Area 728 Eff Area 728
 Length 52 Width 14 Foundation Foundation POST Ex. Wall PLYWD Roof Cover COMP
 Roof Style SHED Floor DIRT Plumbing
 Heat Int. Comp. Elect. *110V* Yr. Blt. 1992 Eff. Yr. Blt: 1992
 Cond. P F A G E Adj. Codes FLCM % Comp ___ Func ___ Econ ___ RMV: 8,500
 Lump Sum _____ Except Code/Year _____ Comments _____

Seg.Type DGU Seg. # **4.1** Method: R05 Class 3 Area 1260 Eff Area 1260
 Length 30 Width 42 Foundation CONC Ex. Wall *Jap* Roof Cover COMP
 Roof Style GABLE Floor CONC Plumbing
 Heat Int. Comp. Elect. Yr. Blt. 2003 Eff. Yr. Blt: 2003
 Cond. P F A G E Adj. Codes RLCM3 % Comp ___ Func ___ Econ ___ RMV: 35,590
 Lump Sum _____ Except Code/Year _____ Comments _____

2X12

R23460 072W20D 02900 Appr #: _____ Date _____ Prop Class 551 Prop Code A23
 Situs Address 1190 CORDON RD NE Franchise Code 19 Year For: 2012-2013
 Owner CUANAS,ALEJANDRO &

Tags Cycle Sales Verification Other: _____

Notes: _____

RMV Land: 146,670 RMV Imp: 126,540 RMV Total: 273,210 M50 Total: 170,680

Segment							Land
Class							
Dim/Size							
Foundation							
Exter Wall							
Wall Height							
Inter Finish							
Roof Cover							
Roof Style							
Flooring							
Plumbing							
Electric							
Misc.							
Yr Blt							
Eff Yr							
Cond.							
% Good							
% Comp							
Lump Sum							
Except.Code							

Land Segments

Seg. No	Description	Schedule	Acres	Adjustment Codes	Exception Code
1	FARM OSD	OSDA.RUR	0.00		
2	FARM HOMESITE	009C	1.00		
3	TWO BENCH DRY	009CG	0.83		

Eff Acres Companion Accounts

ROUTING SLIP

Date _____ Clerk _____

Work Needed: (Please make necessary comments, sign and pass to the next appropriate person.)

Data entry reviewed by/comments _____

APEX: Please review and return appraisal jacket to clerical staff for Apex attachment to TSG.

Appraiser response See 11/7/12

Reviewed by lead appraiser/comments _____





11/07/2012

R23460

DGA 30x42



9 + # 10

mp. 4 + H S. - 4



93 10 27



R23460

GB 14x52

MP 8x12



11/07/2012

R23460

GB 14x52



11/07/2012

R23460

7 x 12 PH



11/07/2012

R23460

8 x 12 MP



11/07/2012

R23460



11/07/2012

R23460



11/07/2012

R23460