

4-4-24
 Acct ID: 533810 MTL: 084W36DC00700 Date: 9/13/23 Appr: WW Prop Class: 451 RMV Prop Class: 451
 Situs: 4468 FOX LN S SALEM OR 97306 3-26-24 MaSaNh: 06 06 000 Unit: 58215 Year: 2023
 Last Date Appraised: 12/15/2022 Appraiser: WENDY WILLIAMS Retag: Y N Tag info: 2024 - Tags/Permit (Completion) 2024
 Owner: SMITH, AARON & SMITH, HALLIE KAY Roll Type: R
 Cycle: Tag Sales Verification Other: _____ Inspection level: 1 2 3 4 LCB TTO INSP AV: 518080
 RMV Land: 295440 RMV Imp: 696430 RMV Total: 991870 MAV: 422130 MSAV: 0 SAV: 0 INPUT WW 11/15/23
 Comment: 23-24: L2 12.15.22 GRH
 22-23: L2 12/15/2021 ML

23-24: ADDN AND REMOD @ 70%, RECHECK FOR COMPLETION and NEW AGF 21-008330
 C/O 4/5/23

ADDN/REMODO @ 100%, CORR SF OF GB

Notations

No notation data available.

AGF NOT PART OF PERMIT - FUTURE PROJECT per owner

OSDs

Count	Code	Description	RMV	Code Area	Exception
1	MKTA	OSD - AVERAGE	45000	14460	0

Land

Site: 1 Code Area: 14460 Size: 2.31 Acres Use Code: 004 Zone: REST SAV Use: Exception: 0
 Class: 2BD Value Source: Rural Restrictive Description: TWO BENCH DRY RMV: 250440 Exception: Y N
 Adjustment(s): H2OGR, GSOIL Fire Patrol: Description:
 Comments: 01-02; REAPPRAISAL

Improvements - Residence / Manufactured Structures

Bldg: 1 Code Area: 14460 Stat Class: 143 + Year Blt: 1962 Eff Year Blt: 2006 Sq.Ft: 3713 % Complete: 100
 Desc: One Story with basement 2010 eyb Dimensions: RMV: 684350
 Func Obsc: 100 Econ %: 100 Other %: 100 Exception: 95950 Adjust: Adjust RMV: 0

Floors

Type	Class	Display Group	Floor Size	Beds	Baths	Yr Blt	Eff Yr Blt	Inventory	ADDN COMP	Exception
First Floor	4 +	Finished	884	0	HE-1	1962	2022	ROOF, BTH - 1, HVAC+		Y N
First Floor	4 +	Finished	1426	1	FB-1/ HB-1	1962	2006	FB, BTH - 1, ROOF, KIT+, HVAC, BATH - 1		Y N
Basement	4 +	Finished	1403	2	FB-2	1962	2006	HVAC, BATH - 2		Y N

Accessories

Description	Class	Size SqFt	Eff Yr Blt	RMV	Quantity
YARD IMPROVEMENTS AVERAGE	4	0	2006	26082	

Sq.Ft.	% Good	.25 = 25%	% of Whole
Basement Finished: 1,403	92%		38%
1st floor: 1,426	92%		38%
2nd Floor:			0%
Attic Finished:			0%
Addition: 884	100%		24%
Total Sq.Ft.: 3,713			100%

Improvements - Accessory Buildings

Bldg: 3 Code Area: 14460 Stat Class: 351 Year Blt: 1960 Eff Year Blt: 1998 Sq.Ft: 1200 % Complete: 100
 Desc: General Purpose Building (GB) Dimensions: 60x20 RMV: 11470
 Func Obsc: 100 Econ %: 100 Other %: 100 Exception: 0 Adjust: Adjust RMV: 0

Floors

Type	Class	Display Group	Floor Size	Beds	Baths	Yr Blt	Eff Yr Blt	Inventory	Exception
General Purpose Bldg	4	Finished	1200	0	0	1960	1998	FAIR	Y N

Accessories

Description	Class	Size SqFt	Eff Yr Blt	RMV	Quantity
No accessory data available					

Bldg: 6 Code Area: 14460 Stat Class: 354 Year Blt: Eff Year Blt: 1998 Sq.Ft: 240 % Complete: 100
 Desc: Lean-to Light (LTL) Dimensions: 20x12 RMV: 610
 Func Obsc: 100 Econ %: 100 Other %: 100 Exception: 0 Adjust: Adjust RMV: 0

Floors

Type	Class	Display Group	Floor Size	Beds	Baths	Yr Blt	Eff Yr Blt	Inventory	Exception
Lean-to Light Duty	4	Finished	240	0	0	0	1998		Y N

Accessories

Description	Class	Size SqFt	Eff Yr Blt	RMV	Quantity
No accessory data available					

SKETCH/AREA TABLE ADDENDUM

SUBJECT INFO

File No.: 533810 Parcel No.: 084W36DC00700
 Property Address: 4468 FOX LN S
 City: SALEM County: State: OR ZipCode: 97306
 Owner:
 Client: Client Address:
 Appraiser Name: Inspection Date:

SKETCH

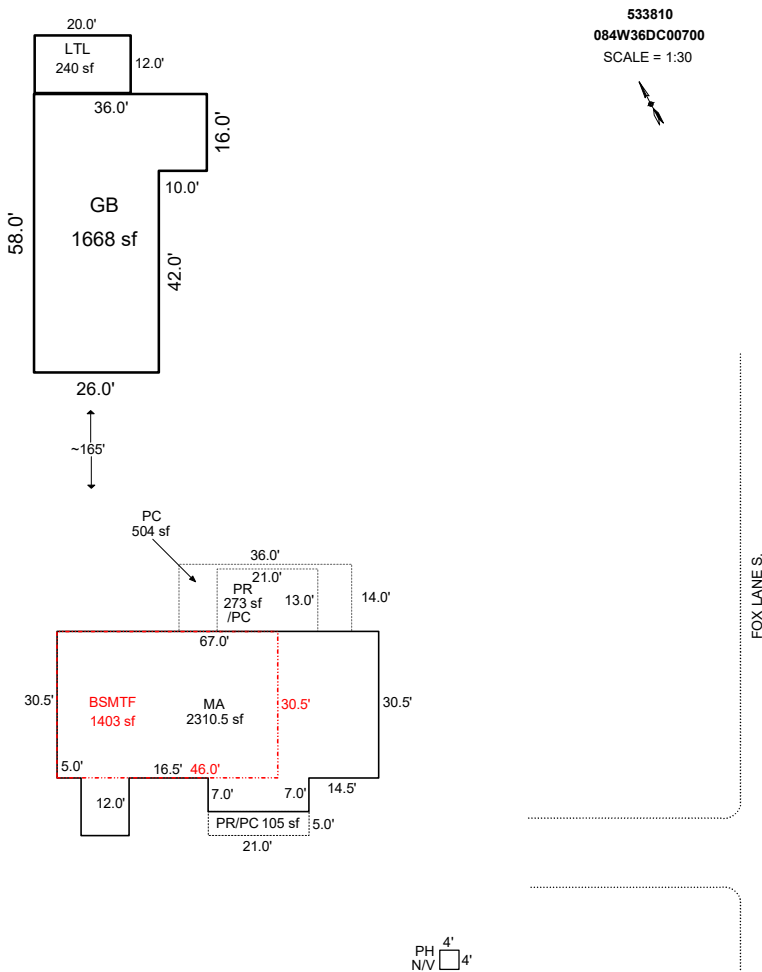

Sketch by ApexSketch

AREA CALCULATIONS SUMMARY						COMMENT TABLE 1									
Code	Description	Factor	Net Size	Perimeter	Net Totals										
GBA1	LTL	1.0	240.0	64.0		APEX BY CE 11/18/09 UPDATED BY CJURAN 10/21/2021 555-21-008330 UPDATED BY WILLIAMS 9/13/23									
	GB	1.0	1668.0	188.0	1908.0										
GLA1	MA	1.0	2310.5	233.0	2310.5										
BSMT	BSMTF	1.0	1403.0	153.0	1403.0										
P/P	PC	1.0	504.0	100.0											
	PR	1.0	273.0	68.0											
	PR/PC	1.0	105.0	52.0	882.0										
	Net LIVABLE	cnt	1 (rounded)		2,311	<table border="1" style="width: 100%; border-collapse: collapse;"> <thead> <tr style="background-color: #f2f2f2;"> <th style="text-align: left;">COMMENT TABLE 2</th> <th style="text-align: left;">COMMENT TABLE 3</th> </tr> </thead> <tbody> <tr> <td>12.15.21 MDL</td> <td>TAGS L3</td> </tr> <tr> <td>12.15.22 GRH</td> <td>TAGS L2</td> </tr> <tr> <td>09.13.23 WW</td> <td>TAGS L4</td> </tr> </tbody> </table>		COMMENT TABLE 2	COMMENT TABLE 3	12.15.21 MDL	TAGS L3	12.15.22 GRH	TAGS L2	09.13.23 WW	TAGS L4
COMMENT TABLE 2	COMMENT TABLE 3														
12.15.21 MDL	TAGS L3														
12.15.22 GRH	TAGS L2														
09.13.23 WW	TAGS L4														
	Net BUILDING	cnt	2 (rounded)		1,908										

