

Acct ID: 536234 MTL: 093W090000100 Date: 10/24/25 23 Appr: MDL Prop Class: 581 RMV Prop Class: 581
 Situs: 10095 LIBERTY RD S SALEM OR 97306 MaSaNh: 07 06 000 Unit: 76883 Year: 2023
 Last Date Appraised: 12/14/2022 Appraiser: MATT LORD Retag: Y N Tag info: 2024 - NEW CONSTRUCTION (Outbuilding)
 Owner: HYNE, JOHN W Roll Type: R
 Cycle: Tag Sales Verification Other: _____ Inspection level: 1 2 3 4 LCB TTO INSP AV: 261464
 RMV Land: 512630 RMV Imp: 506180 RMV Total: 1018810 MAV: 206830 MSAV: 54634 SAV: 81970
 Comment: 23-24: L2 12.14.22 MD
 22-23: L2 09.17.2021 MDL
 LEVEL 2 4.27.21 CL10

Notations 24-25: Shred for cows (23-002679) ✓ completion of House /N/C
House Re-issued (23-002697)
11/1/25 for House completion & Low Side Shed

RP/MS	Code	Description
RP	DFL	DESIGNATED FORESTLAND
RP	ZONED	FARM EFU ZONED

INPUT MDL 12/8/23 WW

OSDs

Count	Code	Description	RMV	Code Area	Exception
1	SAA	SA OSD - AVERAGE	45000	14530	0

Land

Site: 2	Code Area: 14530	Size: 1.00 Acres	Use Code: 005	Zone: REST	SAV Use: 011	Exception: 0
Class: 4HD	Value Source: Farm Homesite	Description: FOUR HILL DRY	RMV: 42410	Exception: Y N		
Adjustment(s):	VWGR, FSOIL	Fire Patrol:	Description:			
Comments:	Liability year - 2009 / 81400130					
Site: 3	Code Area: 14530	Size: 42.30 Acres	Use Code: 005	Zone: REST	SAV Use: 011	Exception: 0
Class: 4HD	Value Source: Farm Use - EFU	Description: FOUR HILL DRY	RMV: 313630	Exception: Y N		
Adjustment(s):	VWGR, FSOIL	Fire Patrol:	Description:			
Comments:	Liability year - 1981 / 81400130 //08-09: 8BENCH PROJECT -CHG OF 8HILL TO 6HILL AND MOVE 6 ACRES TO 4HILL//					
Site: 4	Code Area: 14530	Size: 2.00 Acres	Use Code: 005	Zone: REST	SAV Use: 011	Exception: 0
Class: 6H	Value Source: Farm Use - EFU	Description: SIX HILL	RMV: 14090	Exception: Y N		
Adjustment(s):	VWGR, FSOIL	Fire Patrol:	Description:			
Comments:	Liability year - 1981 / 81400130					
Site: 5	Code Area: 14530	Size: 10.00 Acres	Use Code: 005	Zone: REST	SAV Use: 011	Exception: 0
Class: 4HD	Value Source: Woodlot	Description: FOUR HILL DRY	RMV: 74140	Exception: Y N		
Adjustment(s):	VWGR, FSOIL	Fire Patrol:	Description:			
Comments:	Liability year - 1981 / 81400130					
Site: 6	Code Area: 14530	Size: 3.15 Acres	Use Code: 005	Zone: REST	SAV Use: 011	Exception: 0
Class: FTLC	Value Source: Designated Forest Land	Description: H&B or DFL Class C	RMV: 23360	Exception: Y N		
Adjustment(s):	VWGR, FSOIL	Fire Patrol:	Description:			
Comments:	Liability year - 1981 / 81400130					

Improvements - Residence / Manufactured Structures

Bldg: 3	Code Area: 14530	Stat Class: 144	Year Blt: 2012	Eff Year Blt: 2012	Sq.Ft: 2678	% Complete: 73
Desc:	Multi Story above grade with basement				Dimensions:	RMV: 480120
Func Obsc: 100	Econ %: 100	Other %: 100	Exception: 0	Adjust:	Adjust RMV: 0	

Floors

Type	Class	Display Group	Floor Size	Beds	Baths	Yr Blt	Eff Yr Blt	Inventory	Exception
First Floor	4	Finished	1955	2	FB-1	2012	2012	HVAC, ROOF, KIT-, BATH - 1	Y N
Second Floor	4	Finished	723	1	FB-1	2012	2012	BATH - 1, ROOF	Y N
Basement	4	Unfinished	1283	0	FB-1/ HB-1	2012	2012	HVAC, BTH - 1	Y N
Garage Attached	4	Finished	550	0	0	2012	2012	ROOF	Y N
Garage Basement	4	Finished	672	0	0	2012	2012		Y N

Accessories

Description	Class	Size SqFt	Eff Yr Blt	RMV	Quantity
No accessory data available					

Improvements - Accessory Buildings

Bldg: 1	Code Area: 14530	Stat Class: 351	Year Blt: 1965	Eff Year Blt: 1965	Sq.Ft: 2236 <u>1920</u>	% Complete: 100
Desc:	General Purpose Building (GB)				Dimensions: 50x42 <u>48x40</u>	RMV: 8110
Func Obsc: 100	Econ %: 100	Other %: 100	Exception: 0	Adjust:	Adjust RMV: 0	

Floors

Type	Class	Display Group	Floor Size	Beds	Baths	Yr Blt	Eff Yr Blt	Inventory	Exception: Y (N)
General Purpose Bldg	4	Finished	2236 1920	0	0	1965	1965	FAIR	Exception: Y (N)

Accessories

Description	Class	Size SqFt	Eff Yr Blt	RMV	Quantity
No accessory data available					

Bldg: 2	Code Area: 14530	Stat Class: 353	Year Blt: 2011	Eff Year Blt: 2011	Sq.Ft: 1512	% Complete: 100
Desc: Machine Shed (MS)			Dimensions: 42x36		RMV: 12510	
Func Obsc: 100	Econ %: 100	Other %: 100	Exception: 0	Adjust:	Adjust RMV: 0	

Floors

Type	Class	Display Group	Floor Size	Beds	Baths	Yr Blt	Eff Yr Blt	Inventory	Exception: Y (N)
Machine Shed	4	Finished	1512	0	0	2011	2011		Exception: Y (N)

Accessories

Description	Class	Size SqFt	Eff Yr Blt	RMV	Quantity
No accessory data available					

Bldg: 4	Code Area: 14530	Stat Class: 355	Year Blt: 2012	Eff Year Blt: 2012	Sq.Ft: 480	% Complete: 100
Desc: Lean-to Heavy (LTH)			Dimensions: 30x16		RMV: 3160	
Func Obsc: 100	Econ %: 100	Other %: 100	Exception: 0	Adjust:	Adjust RMV: 0	

Floors

Type	Class	Display Group	Floor Size	Beds	Baths	Yr Blt	Eff Yr Blt	Inventory	Exception: Y (N)
Lean-to Heavy Duty	4	Finished	480	0	0	2012	2012		Exception: Y (N)

Accessories

Description	Class	Size SqFt	Eff Yr Blt	RMV	Quantity
No accessory data available					

Bldg: 5	Code Area: 14530	Stat Class: 353	Year Blt: 1965	Eff Year Blt: 1965	Sq.Ft: 912	% Complete: 100
Desc: Machine Shed (MS)			Dimensions:		RMV: 2280	
Func Obsc: 100	Econ %: 100	Other %: 100	Exception: 0	Adjust:	Adjust RMV: 0	

Floors

Type	Class	Display Group	Floor Size	Beds	Baths	Yr Blt	Eff Yr Blt	Inventory	Exception: Y (N)
Machine Shed	4	Finished	912	0	0	1965	1965		Exception: Y (N)

Accessories

Description	Class	Size SqFt	Eff Yr Blt	RMV	Quantity
No accessory data available					

SKETCH/AREA TABLE ADDENDUM

SUBJECT INFO

File No.: 536234 Parcel No.: 093W09 00100
 Property Address: 10095 LIBERTY RD S
 City: SALEM County: State: OR ZipCode: 97306
 Owner:
 Client: Client Address:
 Appraiser Name: Inspection Date:

SKETCH

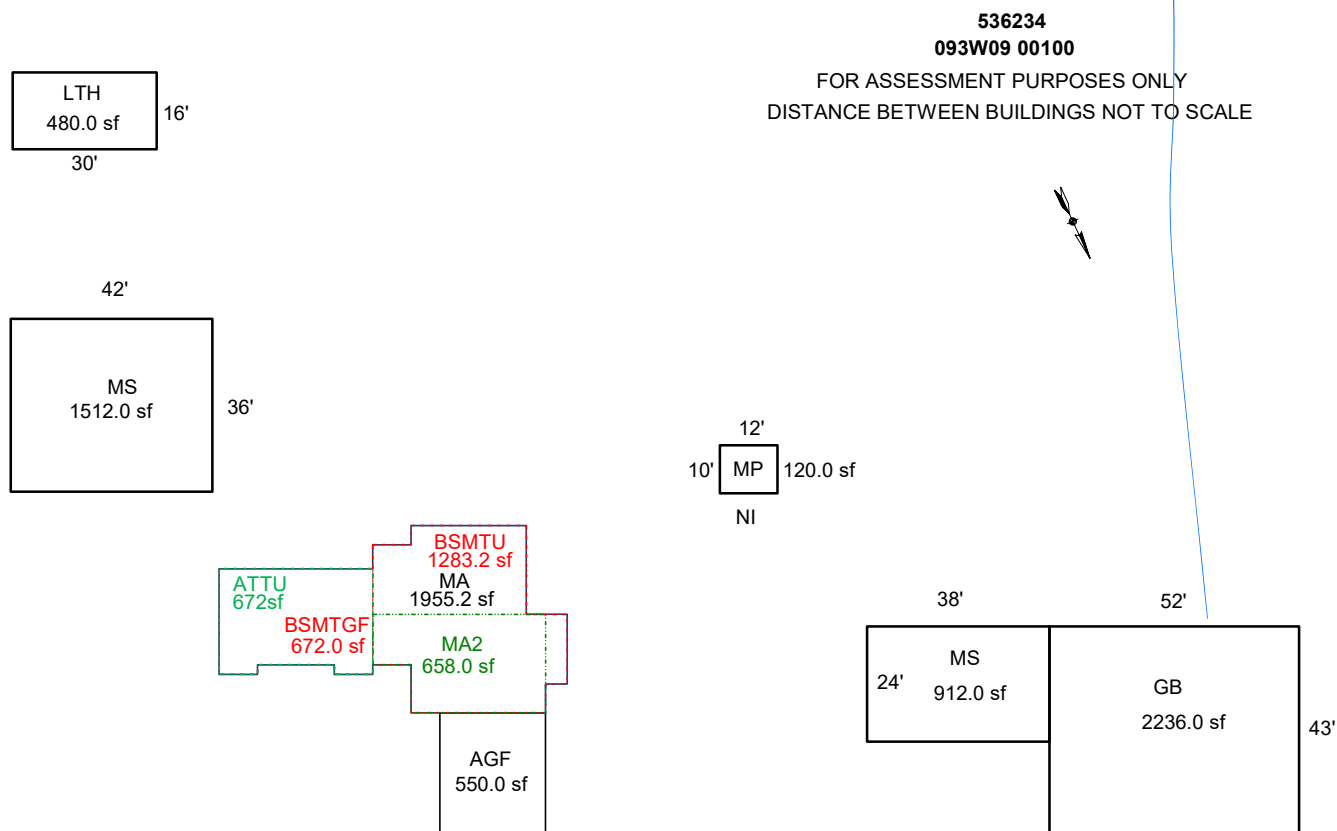

Sketch by ApexSketch

AREA CALCULATIONS SUMMARY						COMMENT TABLE 1	
Code	Description	Factor	Net Size	Perimeter	Net Totals		
GBA1	GB	1.0	2236.0	190.0		APEX BY AC 5/17/13 UPD BY JRONDEMA 5/20/15 UPD BY JRONDEMA 1/16/18 UPD BY PH 08.08.19 UPDATED BY WWILLIAMS 2/29/24	
	MS	1.0	912.0	124.0			
	MS	1.0	1512.0	156.0			
	LTH	1.0	480.0	92.0			
	MP	1.0	120.0	44.0	5260.0		
GLA1	MA	1.0	1955.3	231.0	1955.3		
GLA2	MA2	1.0	658.0	113.0	658.0		
BSMT	BSMTU	1.0	1283.3	159.0			
	BSMTU	1.0	672.0	112.0			
	ATTU	1.0	672.0	112.0	2627.3		
GARG	AGF	1.0	550.0	94.0	550.0	COMMENT TABLE 2	COMMENT TABLE 3
						11/19/18 #35 MDL 10/24/23	TAGS L2
	Net LIVABLE	cnt	2 (rounded)		2,613		
	Net BUILDING	cnt	5 (rounded)		5,260		



R36234 AGF 11.19.18



R36234 BATH 11.19.18



R36234 KITCHEN 11.19.18



R36234 LIVING 11.19.18



R36234
BSMTGF, MA SIDE

3-29-18



R36234

BSMTGF, MA

3-29-18



R36234

LTH

3-29-18



R36234

MA,MA2,AGF

3-29-18



R36234

MS,GB

3-29-18



R36234

MS 36X42

3-29-18



R36234

SHED N/I

3-29-18



R36234

GB 32X36

12-21-17



R36234

GB 48X40

12-21-17



R36234

MA

12-21-17





9/17/2021

R36234 E MA 2021-09-17
L2



9/17/2021

R36234 Front MA 2021-09-17
L2









R36234back

01-6-2014



R36234front

01-6-2014



R36234side

01-6-2014



R36234back (2)

02-8-2016



R36234front (2)

02-8-2016















CHEVROLET