

Acct ID: 535636 MTL: 092W24C002500 Date: 1/9/24 Appr: MDL Prop Class: 401 RMV Prop Class: 401
 Situs: 12523 BRICK RD SE TURNER OR 97392 MaSaNh: 07 06 000 Unit: 84946 Year: 2023
 Last Date Appraised: 01/13/2023 Appraiser: MATT LORD Retag: Y N Tag info: 2024 - Tags/Permit (Completion) 2024
 Owner: RAY, WILLIAM L & ARAY, ALACE & Roll Type: R
 Cycle: Tag Sales Verification Other: _____ Inspection level: 1 2 3 4 LCB TTO INSP AV: 348060
 RMV Land: 170030 RMV Imp: 517280 RMV Total: 687310 MAV: 301590 MSAV: 0 SAV: 0
 Comment: 23-24: L2 1.13.23 MDL 22-000689

Notations 24-25: v addition completion 100%
 No notation data available.

OSDs

Count	Code	Description	RMV	Code Area	Exception
1	MKTF	OSD - FAIR	35000	05545	0

Land

Site: 1 Code Area: 05545 Size: 1.00 Acres Use Code: 004 Zone: NREST SAV Use: Exception: 0
 Class: 2BI Value Source: Rural at MKT Description: TWO BENCH IRR RMV: 135030 Exception: Y N
 Adjustment(s): GSOIL, IRR Fire Patrol: Description:
 Comments: 2002-03 REAPPRAISAL. //2-16-07 (GW39): Change from 008 to 007.

Improvements - Residence / Manufactured Structures

Bldg: 4 Code Area: 05545 Stat Class: 141 Year Blt: 2014 Eff Year Blt: 2014 Sq.Ft: 2560 % Complete: 100
 Desc: One Story Only Dimensions: RMV: 441200
 Func Obsc: 100 Econ %: 100 Other %: 100 Exception: 46470 Adjust: Adjust RMV: 0

Floors

Type	Class	Display Group	Floor Size	Beds	Baths	Yr Blt	Eff Yr Blt	Inventory	Exception
First Floor	4	Finished	2112	0	FB-2	2014	2014	HVAC, ROOF, BATH+, KIT, BATH - 2	Y N
First Floor	4	Finished	448	0	0	2014	2014	<u>100% Complete</u>	Y N
Garage Attached	4	Unfinished	528	0	0	2014	2014	ROOF	Y N

Accessories

Description	Class	Size SqFt	Eff Yr Blt	RMV	Quantity	Exception
YARD IMPROVEMENTS AVERAGE	4	0	2014	27216	1	Y N

Improvements - Accessory Buildings

Bldg: 1 Code Area: 05545 Stat Class: 351 Year Blt: 1976 Eff Year Blt: 1976 Sq.Ft: 624 % Complete: 100
 Desc: General Purpose Building (GB) Dimensions: 26x24 RMV: 2120
 Func Obsc: 100 Econ %: 100 Other %: 100 Exception: 0 Adjust: Adjust RMV: 0

Floors

Type	Class	Display Group	Floor Size	Beds	Baths	Yr Blt	Eff Yr Blt	Inventory	Exception
General Purpose Bldg	4	Finished	624	0	0	1976	1976		Y N

Accessories

Description	Class	Size SqFt	Eff Yr Blt	RMV	Quantity	Exception
No accessory data available						

Bldg: 2 Code Area: 05545 Stat Class: 354 Year Blt: Eff Year Blt: Sq.Ft: 160 % Complete: 100
 Desc: Lean-to Light (LTL) Dimensions: 16x10 RMV: 810
 Func Obsc: 100 Econ %: 100 Other %: 100 Exception: 0 Adjust: Adjust RMV: 0

Floors

Type	Class	Display Group	Floor Size	Beds	Baths	Yr Blt	Eff Yr Blt	Inventory	Exception
Lean-to Light Duty	4	Finished	160	0	0	0	0		Y N

Accessories

Description	Class	Size SqFt	Eff Yr Blt	RMV	Quantity	Exception
No accessory data available						

Bldg: 3 Code Area: 05545 Stat Class: 351 Year Blt: 1986 Eff Year Blt: 1986 Sq.Ft: 576 % Complete: 100
 Desc: General Purpose Building (GB) Dimensions: 36x16 RMV: 3800
 Func Obsc: 100 Econ %: 100 Other %: 100 Exception: 0 Adjust: Adjust RMV: 0

Floors

Type	Class	Display Group	Floor Size	Beds	Baths	Yr Blt	Eff Yr Blt	Inventory
General Purpose Bldg	5	Finished	576	0	0	1986	1986	Exception: Y N

Accessories

Description	Class	Size SqFt	Eff Yr Blt	RMV	Quantity
No accessory data available					

Bldg: 5 Code Area: 05545 Stat Class: 351 Year Blt: 2015 Eff Year Blt: 2015 Sq.Ft: 3360 % Complete: 100
 Desc: General Purpose Building (GB) Dimensions: 40x84 RMV: 69350
 Func Obsc: 100 Econ %: 100 Other %: 100 Exception: 0 Adjust: Adjust RMV: 0

Floors

Type	Class	Display Group	Floor Size	Beds	Baths	Yr Blt	Eff Yr Blt	Inventory
General Purpose Bldg	5	Finished	3360	0	0	2015	2015	FAIR Exception: Y N

Accessories

Description	Class	Size SqFt	Eff Yr Blt	RMV	Quantity
No accessory data available					

SKETCH/AREA TABLE ADDENDUM

SUBJECT INFO

File No.: 535636 Parcel No.: 092W24C 02500
 Property Address: 12523 BRICK RD SE
 City: TURNER County: MARION State: OR ZipCode: 97392
 Owner:
 Client: Client Address:
 Appraiser Name: Inspection Date:

SKETCH

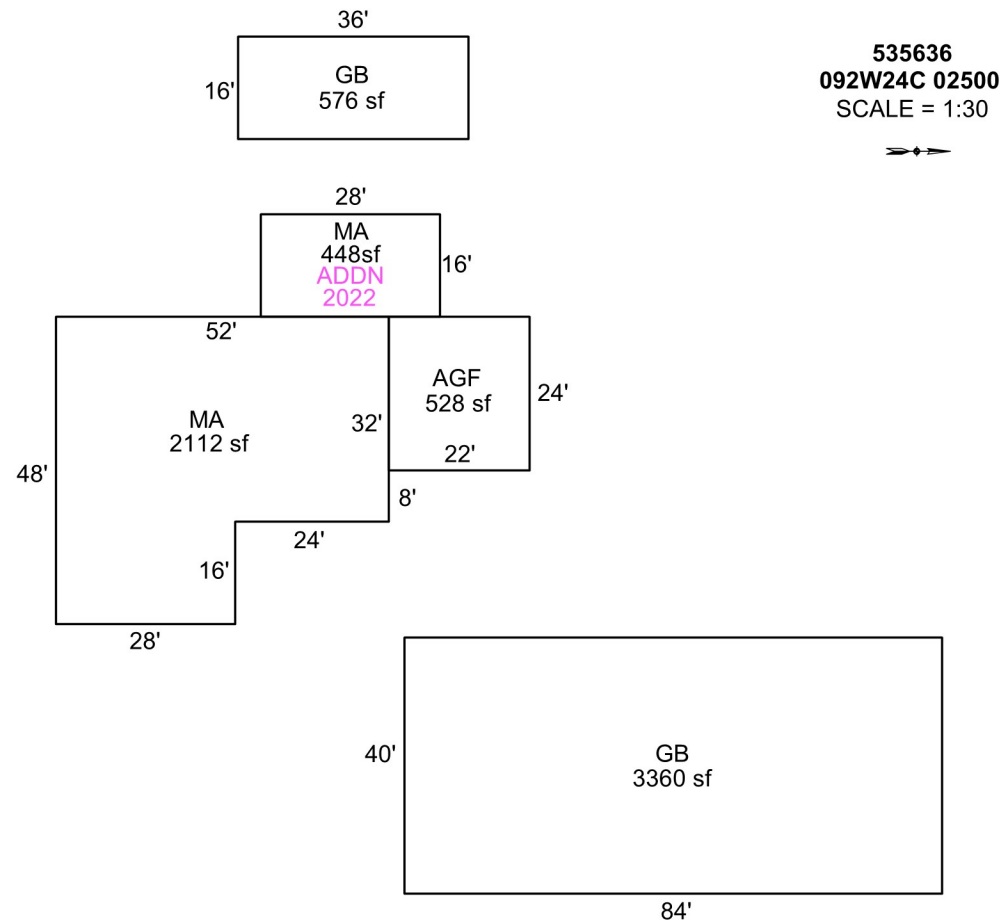

Sketch by Apex Sketch

AREA CALCULATIONS SUMMARY

Code	Description	Factor	Net Size	Perimeter	Net Totals
GBA2	GB	1	576	104	
	GB	1	3360	248	3936
GLA1	MA	1	2112	200	
	MA	1	448	88	2560
GAR	AGF	1	528	92	528
	Net LIVABLE	cnt	2 (rounded)		2,560
	Net BUILDING	cnt	2 (rounded)		3,936

COMMENT TABLE 1

DRAWN BY SRAGSDALE 11/13/14
 UPDATED BY JRONDEMA 5/11/15
 UPDATED BY JRONDEMA 8/10/15
 UPDATED BY JRONDEMA 2/16/16
 UPDATED BY CJURNA 03/09/2022 555-22-000689

COMMENT TABLE 2

#36 DB 1/25/16
 MDL 12/13/23

COMMENT TABLE 3

L3 TAB





1/9/24