

Summary Lead Appr: WW Clerk: _____ Lead Clerk: _____ Appr: _____ Print Date:

7/31/2023

Acct ID: 127491 MTL: 092W110000100P1 Date: 1/8/24 Appr: MN Prop Class: 049 RMV Prop Class: 049

Situs: 8207 SHAFF RD SE TURNER, OR 97392 MaSaNh: 07 06 000 Unit: 127491 Year: 2023

Last Date Appraised: 07/18/2008 Appraiser: MATT LORD Retag: Y N Tag info: 2024 - Tags/Permit (Demolished)

Owner: ZIMMERMAN,DONALD A & ZIMMERMAN,DEBBIE R Roll Type: MS

Cycle Tag Sales Verification Other: _____ Inspection level: 1 2 3 4 LCB TTO INSP AV: 13650

RMV Land: 0 RMV Imp: 31410 RMV Total: 31410 MAV: 13650 MSAV: 0 SAV: 0

Comment: MFD STRUCT SERIAL # 14X703PDRMS6734, X # X00134899 ON REAL ACCT 092W11 00100, PERSONAL MS

Notations

MFL Demo

emailed mwiltse 3/13/24 ww

RP/MS	Code	Description
MS	ZONED	FARM EFU ZONED

OSDs

No OSD data available.

Land

No land data available.

Improvements - Residence / Manufactured Structures

Bldg: 1 Code Area: 05555 Stat Class: 454 Year Blt: 1976 Eff Year Blt: 1973 Sq.Ft: 1134 % Complete: 100
 Desc: MANUF STRUCT, CLASS 5, 14' WIDE SINGLE Dimensions: RMV: 31410
 Func Obsc: 100 Econ %: 100 Other %: 100 Exception: 0 Adjust: Adjust RMV: 0

Floors

Type	Class	Display Group	Floor Size	Beds	Baths	Yr Blt	Eff Yr Blt	Inventory	Exception: Y N
First Floor	5	Finished	1134	2	FB-1	1976	1973	BATH - 1, KIT-, HVAC+, ROOF+, SKIRT	Y N

Accessories

Description	Class	Size SqFt	Eff Yr Blt	RMV	Quantity	Exception: Y N
ENCLOSED PORCH	2	84	1973	420	0	Y N

Improvements - Accessory Buildings

No improvement data available for all other stat class types.

R35250
 092W11 00100
 SCALE=1:70

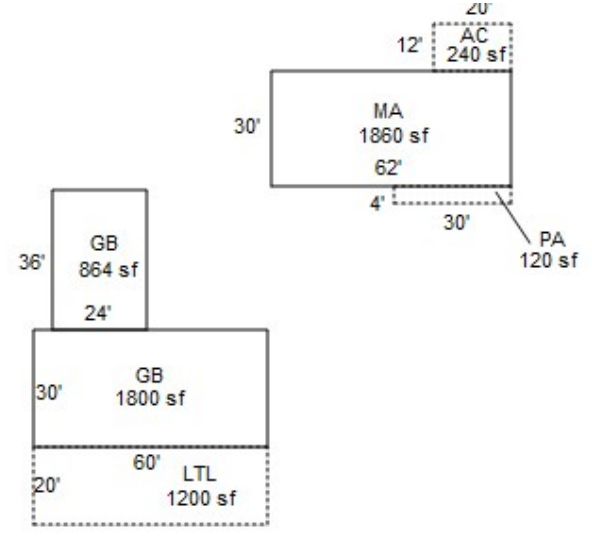

APPROX 875' BETWEEN

