

Acct ID: 528870 MTL: 081W32A000600 Date: 3-27-24 Appr: WW Prop Class: 401 RMV Prop Class: 401
 Situs: 8253 GOLF CLUB RD SE AUMSVILLE OR 97325 MaSaNh: 01 06 008 Unit: 28208 Year: 2024
 Last Date Appraised: 08/13/2020 Appraiser: CLINT LUKE Retag: Y N Tag info: _____
 Owner: JACK YARBROUGH RLT Roll Type: R
 Cycle Tag: Sales Verification Other: _____ Inspection level: 1 2 3 4 LCB TTO INSP AV: 522900
 RMV Land: 254370 RMV Imp: 785020 RMV Total: 1039390 MAV: 522900 MSAV: 0 SAV: 0
 Comment: _____

INPUT
4-2-24
WW

Notations NOT ON MKT PER SV IN LF 20
 No notation data available.

OSDs NO CHANGE TO ACCT

Count	Code	Description	RMV	Code Area	Exception
1	MKTA	OSD - AVERAGE	45000	29558	0

Land
 Site: 1 Code Area: 29558 Size: 1.59 Acres Use Code: 004 Zone: NREST SAV Use: _____ Exception: 0
 Class: _____ Value Source: Rural at MKT Description: _____ RMV: 209370 Exception: Y N
 Adjustment(s): _____ Fire Patrol: _____ Description: _____
 Comments: 18-19: PER #102 ADD OSD / 2002-03 REAPPRAISAL; 2003-04 MODIFIED LAND TABLE KKB65 10/02

Improvements - Residence / Manufactured Structures
 Bldg: 1 Code Area: 29558 Stat Class: 152 Year Blt: 2017 Eff Year Blt: 2017 Sq.Ft: 3148 % Complete: 100
 Desc: Multi Story above grade Dimensions: _____ RMV: 592380
 Func Obsc: 100 Econ %: 100 Other %: 100 Exception: 0 Adjust: _____ Adjust RMV: 0

Floors

Type	Class	Display Group	Floor Size	Beds	Baths	Yr Blt	Eff Yr Blt	Inventory	Exception: Y N
First Floor	5	Finished	2696	4	FB-2/ HB-1	2017	2017	ROOF, FP - 1, HVAC+, KIT-, BATH - 2, BATH+, BTH - 1	Exception: Y N
Attic	5	Finished	452	0	FB-1/ HB-1	2017	2017	HVAC+, BTH - 1	Exception: Y N
Garage Attached	5	Finished	704	0	0	2017	2017	ROOF	Exception: Y N

Accessories

Description	Class	Size SqFt	Eff Yr Blt	RMV	Quantity	Exception: Y N
CONCRETE DRIVEWAY	5	528	2017	1665	1	Exception: Y N
PATIO	5	214	2017	1142	1	Exception: Y N
PATIO	5	508	2019	2738	1	Exception: Y N
ROOF EXTENSION OR PATIO COVER	5	204	2017	5739	1	Exception: Y N
ROOF EXTENSION OR PATIO COVER	5	214	2017	6020	1	Exception: Y N

Bldg: 2 Code Area: 29558 Stat Class: 108 Year Blt: 2018 Eff Year Blt: 2018 Sq.Ft: 0 % Complete: 100
 Desc: Residential Other Improvements Dimensions: _____ RMV: 5290
 Func Obsc: 100 Econ %: 100 Other %: 100 Exception: 0 Adjust: _____ Adjust RMV: 0

Floors

Type	Class	Display Group	Floor Size	Beds	Baths	Yr Blt	Eff Yr Blt	Inventory	Exception: Y N
No floor data available									

Accessories

Description	Class	Size SqFt	Eff Yr Blt	RMV	Quantity	Exception: Y N
ASPHALT DRIVEWAY	1	1800	2018	5292	1	Exception: Y N

Bldg: 3 Code Area: 29558 Stat Class: 158 Year Blt: 2019 Eff Year Blt: 2019 Sq.Ft: 660 % Complete: 100
 Desc: Res other improvements Dimensions: _____ RMV: 187350
 Func Obsc: 100 Econ %: 100 Other %: 100 Exception: 0 Adjust: _____ Adjust RMV: 0

Floors

Type	Class	Display Group	Floor Size	Beds	Baths	Yr Blt	Eff Yr Blt	Inventory	Exception: Y N
Second Floor	5	Finished	660	0	FB-1	2019	2019	BATH - 1	Exception: Y N
Garage Oversized Detached	5	Finished	1020	0	0	2019	2019	ROOF	Exception: Y N

Accessories

Description	Class	Size SqFt	Eff Yr Blt	RMV	Quantity	Exception: Y N
No accessory data available						

Improvements - Accessory Buildings

No improvement data available for all other stat class types.

R28870
081W32A 00600

SCALE=1:25

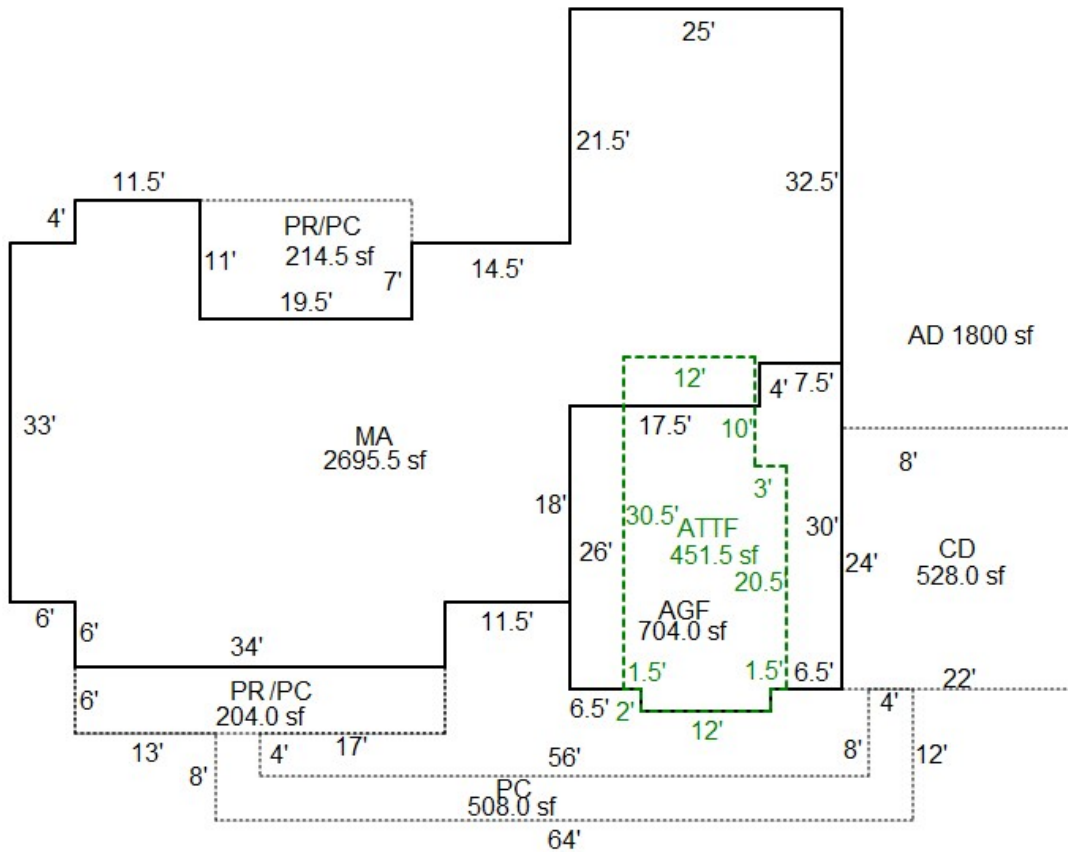
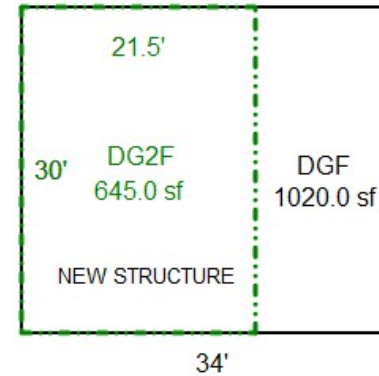

FOR ASSESSMENT PURPOSES ONLY
DISTANCE BETWEEN BUILDINGS NOT TO SCALE

*Leave
3/27/24
SV LH*