

Acct ID: 529293 MTL: 082W03B005800 Date: 5-9-24 Appr: QWCB Prop Class: 451 RMV Prop Class: 451
 Situs: 6840 MACLEAY RD SE SALEM OR 97317 MaSaNh: 01 06 000 Unit: 53765 Year: 2024
 Last Date Appraised: 06/03/2021 Appraiser: CLINT LUKE Retag: Y N Tag info: _____
 Owner: BAILEY, KEVIN ADAM Roll Type: R
 Cycle Tag Sales Verification Other: _____ Inspection level: 1 2 3 4 LCB TTO INSP AV: 313410
 RMV Land: 243920 RMV Imp: 300030 RMV Total: 543950 MAV: 313410 MSAV: 0 SAV: 0

INPUT FROM CITRUS'S 5/13/24

Comment: LEVEL 2 6.3.21 WV06//
MLS 802444 LP 598,000
DOM 392 SP 598,000

30

Notations No notation data available.

ENTERED ON LLA WORKFLOW 529293

OSDs

| Count | Code | Description | RMV | Code Area | Exception |
|-------|------|---------------|-------|-----------|-----------|
| 1 | MKTA | OSD - AVERAGE | 45000 | 92410 | 0 |

Land

Site: 1 Code Area: 92410 Size: 1.37 Acres Use Code: 005 Zone: REST SAV Use: Exception: 0
 Class: 4HD Value Source: Rural Restrictive Description: FOUR HILL DRY RMV: 198920 Exception: Y N
 Adjustment(s): Fire Patrol: Description:
 Comments: 2010-11: MAP ROOM ACREAGE CORRECTION FROM 1.40 TO 1.37// 2002-03 REAPPRAISAL; 2003-04 MODIFIED LAND TABLE KKB65 10/02

Improvements - Residence / Manufactured Structures

Bldg: 1 Code Area: 92410 Stat Class: 142 + Year Blt: 1976 Eff Year Blt: 1988 OK Sq.Ft: 2162 % Complete: 100
 Desc: Multi Story above grade Dimensions: RMV: 300030
 Func Obsc: 100 Econ %: 100 Other %: 100 Exception: 0 Adjust: Adjust RMV: 0

Floors

| Type | Class | Display Group | Floor Size | Beds | Baths | Yr Blt | Eff Yr Blt | Inventory | Exception: Y N |
|--------------|-------|---------------|------------|------|---------------|--------|------------|---|----------------|
| First Floor | 4 + | Finished | 1448 | 1 | FB-1/ HB-1 | 1976 | 1988 | FP - 1, KIT, BTH - 1, HVAC+, ROOF, BATH - 1 | Y N |
| Second Floor | 4 + | Finished | 612 | 2 | FB-1 | 1976 | 1988 | HVAC+, BATH - 1 | Y N |
| Attic | 4 + | Finished | 102 | 0 | 0 | 1976 | 1988 | HVAC+ | Y N |

AWKWB

Accessories

| Description | Class | Size SqFt | Eff Yr Blt | RMV | Quantity | Exception: Y N |
|-------------------------------|-------|-----------|------------|------|----------|----------------|
| CONCRETE DRIVEWAY | 4 | 360 | 1988 | 971 | 1 | Exception: Y N |
| DECK | 4 | 40 | 1988 | 730 | 1 | Exception: Y N |
| DECK | 4 | 45 | 1988 | 822 | 1 | Exception: Y N |
| DECK | 4 | 256 | 1988 | 4675 | 1 | Exception: Y N |
| ROOF EXTENSION OR PATIO COVER | 4 | 45 | 1988 | 1083 | 1 | Exception: Y N |
| ROOF EXTENSION OR PATIO COVER | 4 | 84 | 1988 | 2022 | 1 | Exception: Y N |

Y14A

Y0

Improvements - Accessory Buildings

No improvement data available for all other stat class types.

SKETCH/AREA TABLE ADDENDUM

SUBJECT INFO

File No.: R29293 Parcel No.: 082W03B 05800
 Property Address: 6840 MACLEAY RD SE
 City: SALEM County: MARION State: OR ZipCode: 97317
 Owner:
 Client:
 Appraiser Name: Client Address: Inspection Date:

SKETCH

R29293
082W03B 05800
 SCALE=1:20

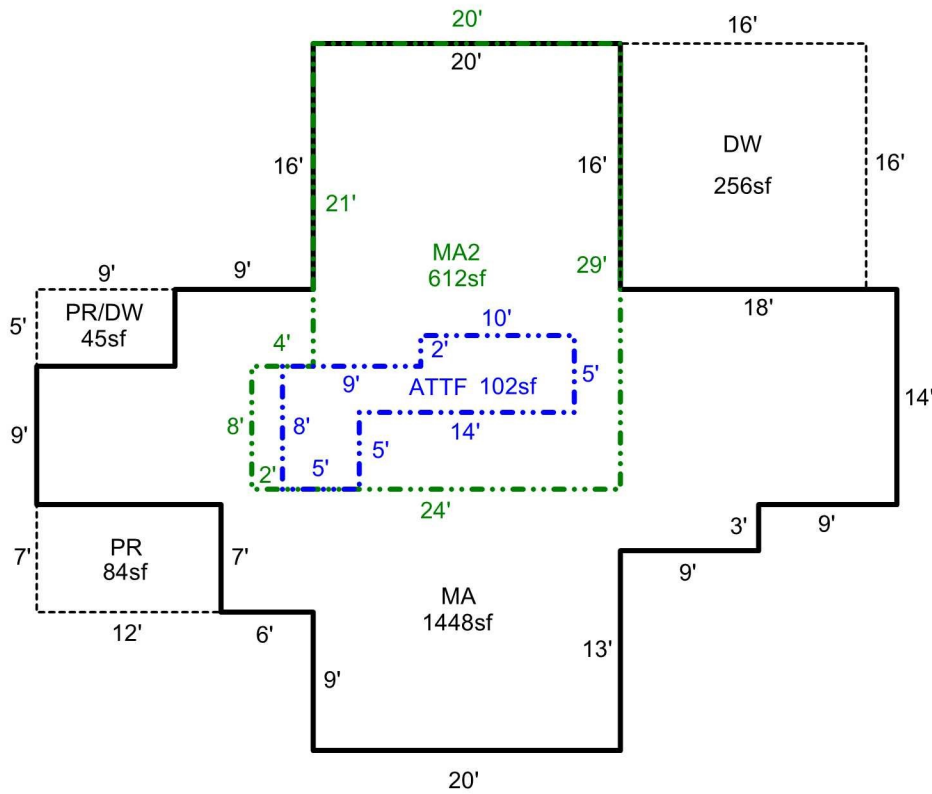

Sketch by Apex Sketch

AREA CALCULATIONS SUMMARY

| Code | Description | Factor | Net Size | Perimeter | Net Totals |
|------|-------------|--------|----------|-----------|------------|
| GLA1 | MA | 1.0 | 1448.0 | 204.0 | 1448.0 |
| GLA2 | MA2 | 1.0 | 612.0 | 106.0 | 612.0 |
| GLA3 | ATTF | 1.0 | 102.0 | 58.0 | 102.0 |
| P/P | DW | 1.0 | 256.0 | 64.0 | |
| | PR/DW | 1.0 | 45.0 | 28.0 | |
| | PR | 1.0 | 84.0 | 38.0 | 385.0 |

COMMENT TABLE 1

DRAWN BY JRONDEMA 2/16/18
 UPDATED BY CJURAN 06/10/2021

COMMENT TABLE 2

#06 WV 06/03/2021

COMMENT TABLE 3

OWN REQ L2

Line
5-9-24
SV L4

Net LIVABLE cnt 3 (rounded) 2,162