

Acct ID: 534890 MTL: 091W18A001100 Date: 1/9/24 Appr: MDL Prop Class: 459 RMV Prop Class: 459
 Situs: 12384 WEST STAYTON RD SE AUMSVILLE OR 97325 MaSaNh: 07 06 000 Unit: 71627 Year: 2023
 Last Date Appraised: 05/13/2013 Appraiser: MATT LORD Retag: Y N Tag info: 2024 - NEW CONSTRUCTION (Residence)
 Owner: BOATMAN, PHILLIP DANIEL Roll Type: R
 Cycle: Tag Sales Verification Other: _____ Inspection level: 1 2 3 4 LCB TTO INSP AV: 135620
 RMV Land: 159310 RMV Imp: 78650 RMV Total: 237960 MAV: 135620 MSAV: 0 SAV: 0
 Comment: Attached to part of old MFH Exception

Notations 24-25 MS Placement (606564) / 100% complete Pull TAB
 No notation data available.

OSDs

Count	Code	Description	RMV	Code Area	Exception
1	MKTA	OSD - AVERAGE	45000	05545	0

Land

Site: 1 Code Area: 05545 Size: 0.92 Acres Use Code: 004 Zone: REST SAV Use: Exception: 0
 Class: Value Source: Rural Restrictive Description: RMV: 114310 Exception: Y N
 Adjustment(s): Fire Patrol: Description:
 Comments: 2002-03 REAPPRAISAL.

Improvements - Residence / Manufactured Structures

Bldg: 1 Code Area: 05545 Stat Class: 158 Year Blt: 1987 Eff Year Blt: 1901 Sq.Ft: 0 % Complete: 100
 Desc: Res other improvements Dimensions: RMV: 41170
 Func Obsc: 100 Econ %: 100 Other %: 100 Exception: 0 Adjust: Adjust RMV: 0

Floors

Type	Class	Display Group	Floor Size	Beds	Baths	Yr Blt	Eff Yr Blt	Inventory	Exception
Garage Detached	3	Unfinished	300	0	0	1980	1901	ROOF	Exception: Y N
Carport Detached	5	Unfinished	360	0	0	1987	1901	ROOF	Exception: Y N

Accessories

Description	Class	Size SqFt	Eff Yr Blt	RMV	Quantity	Exception
ROOF EXTENSION OR PATIO COVER	5	300	1986	7134	1	Exception: Y N
YARD IMPROVEMENTS AVERAGE	3	1	1901	6804	1	Exception: Y N

Bldg: 1 Code Area: 05545 Stat Class: 441 Year Blt: Eff Year Blt: Sq.Ft: 0 % Complete: 100
 Desc: MANUF STRUCT, CLASS 4, 8' WIDE SINGLE Dimensions: RMV: 0
 Func Obsc: 100 Econ %: 100 Other %: 100 Exception: 0 Adjust: Adjust RMV: 0

Floors

Type	Class	Display Group	Floor Size	Beds	Baths	Yr Blt	Eff Yr Blt	Inventory	Exception
No floor data available									

Accessories

Description	Class	Size SqFt	Eff Yr Blt	RMV	Quantity	Exception
No accessory data available						

Bldg: 9 Code Area: 05545 Stat Class: 451 Year Blt: 1984 Eff Year Blt: 1984 Sq.Ft: 1344 % Complete: 100
 Desc: MANUF STRUCT, CLASS 5, 8' WIDE SINGLE Dimensions: RMV: 33640
 Func Obsc: 100 Econ %: 100 Other %: 100 Exception: 0 Adjust: Adjust RMV: 0

Floors

Type	Class	Display Group	Floor Size	Beds	Baths	Yr Blt	Eff Yr Blt	Inventory	Exception
First Floor	5	Finished	1344	0	FB-2	1984	1984	KIT-, ROOF+, SKIRT	Exception: Y N

Accessories

Description	Class	Size SqFt	Eff Yr Blt	RMV	Quantity	Exception
No accessory data available						

Improvements - Accessory Buildings

Bldg: 2 Code Area: 05545 Stat Class: 301 Year Blt: 1980 Eff Year Blt: 1980 Sq.Ft: 36 % Complete: 100
 Desc: Accessory Improvements & Misc. Dimensions: 6x6 RMV: 0
 Func Obsc: 100 Econ %: 100 Other %: 100 Exception: 0 Adjust: Adjust RMV: 0

Floors

Type	Class	Display Group	Floor Size	Beds	Baths	Yr Blt	Eff Yr Blt	Inventory	Exception
No floor data available									

Type	Class	Display Group	Floor Size	Beds	Baths	Yr Blt	Eff Yr Blt	Inventory
Pump House	0	Finished	36	0	0	1980	1980	Exception: Y N

Accessories

Description	Class	Size SqFt	Eff Yr Blt	RMV	Quantity
-------------	-------	-----------	------------	-----	----------

No accessory data available

Bldg: 3	Code Area: 05545	Stat Class: 341	Year Blt: 1986	Eff Year Blt: 1986	Sq.Ft: 96	% Complete: 100
Desc: Multi Purpose Shed (MP)			Dimensions: 12x8			RMV: 130
Func Obsc: 100	Econ %: 100	Other %: 100	Exception: 0	Adjust:	Adjust RMV: 0	

Floors

Type	Class	Display Group	Floor Size	Beds	Baths	Yr Blt	Eff Yr Blt	Inventory
Multi-Purpose Bldg	4	Finished	96	0	0	1986	1986	FAIR Exception: Y N

Accessories

Description	Class	Size SqFt	Eff Yr Blt	RMV	Quantity
-------------	-------	-----------	------------	-----	----------

No accessory data available

Bldg: 4	Code Area: 05545	Stat Class: 341	Year Blt: 1986	Eff Year Blt: 1986	Sq.Ft: 4864	% Complete: 100
Desc: Multi Purpose Shed (MP)			Dimensions: 8x68			RMV: 0
Func Obsc: 100	Econ %: 100	Other %: 100	Exception: 0	Adjust:	Adjust RMV: 0	

Floors

Type	Class	Display Group	Floor Size	Beds	Baths	Yr Blt	Eff Yr Blt	Inventory
Multi-Purpose Bldg	4	Finished	4864	0	0	1986	1986	Exception: Y N

Accessories

Description	Class	Size SqFt	Eff Yr Blt	RMV	Quantity
-------------	-------	-----------	------------	-----	----------

No accessory data available

Bldg: 5	Code Area: 05545	Stat Class: 341	Year Blt: 1991	Eff Year Blt: 1991	Sq.Ft: 210	% Complete: 100
Desc: Multi Purpose Shed (MP)			Dimensions:			RMV: 1760
Func Obsc: 100	Econ %: 100	Other %: 100	Exception: 0	Adjust:	Adjust RMV: 0	

Floors

Type	Class	Display Group	Floor Size	Beds	Baths	Yr Blt	Eff Yr Blt	Inventory
Multi-Purpose Bldg	4	Finished	210	0	0	1991	1991	Exception: Y N

Accessories

Description	Class	Size SqFt	Eff Yr Blt	RMV	Quantity
-------------	-------	-----------	------------	-----	----------

No accessory data available

Bldg: 6	Code Area: 05545	Stat Class: 354	Year Blt: 1991	Eff Year Blt: 1991	Sq.Ft: 144 525	% Complete: 100
Desc: Lean-to Light (LTL) HC			Dimensions: 12x12			RMV: 260
Func Obsc: 100	Econ %: 100	Other %: 100	Exception: 0	Adjust: 214 25	Adjust RMV: 0	

Floors

Type	Class	Display Group	Floor Size	Beds	Baths	Yr Blt	Eff Yr Blt	Inventory
Lean-to Light Duty	4	Finished	144 525	0	0	1991	1991	Exception: Y N

Accessories

Description	Class	Size SqFt	Eff Yr Blt	RMV	Quantity
-------------	-------	-----------	------------	-----	----------

No accessory data available

Bldg: 7	Code Area: 05545	Stat Class: 355	Year Blt: 1986	Eff Year Blt: 1986	Sq.Ft: 408	% Complete: 100
Desc: Lean-to Heavy (LTH)			Dimensions:			RMV: 900
Func Obsc: 100	Econ %: 100	Other %: 100	Exception: 0	Adjust:	Adjust RMV: 0	

Floors

Type	Class	Display Group	Floor Size	Beds	Baths	Yr Blt	Eff Yr Blt	Inventory
Lean-to Heavy Duty	4	Finished	408	0	0	1986	1986	Exception: Y N

Accessories

Description	Class	Size SqFt	Eff Yr Blt	RMV	Quantity
-------------	-------	-----------	------------	-----	----------

No accessory data available

Bldg: 8	Code Area: 05545	Stat Class: 354	Year Blt:	Eff Year Blt:	Sq.Ft: 156 112	% Complete: 100
Desc: Lean-to Light (LTL)			Dimensions: 13x12			RMV: 790
Func Obsc: 100	Econ %: 100	Other %: 100	Exception: 0	Adjust: 8x14	Adjust RMV: 0	

Floors

Type	Class	Display Group	Floor Size	Beds	Baths	Yr Blt	Eff Yr Blt	Inventory
Lean-to Light Duty	4	Finished	156 112	0	0	0	0	Exception: Y N

Accessories

Description	Class	Size SqFt	Eff Yr Blt	RMV	Quantity
No accessory data available					

MA (Attached to MFS)
 Eff Yr 1984
 31424

ACCOUNT # 534890 DATE: 1/9/24 RMV CLASS _____ PROP CLASS _____
 MTL 91W 18A 1100 APPR MDL TAG Y (N)
 COMMENTS: _____

RESIDENCE / MANUFACTURED STRUCTURES

ACCESSORY IMPROVEMENTS / OUTBUILDINGS

STAT 454 QLTY + - FLOOR MA
 AREA 1347 EFF AREA 1347 BED 3
 ROOF + 844 HVAC + 844
 BATH PKG: _____ BATH 2 BATH + _____ 1/2 BTH
 FIREPLACE: _____
 KITCHEN - +
 YR BLT 2023 EFF YR 2023 ECON _____
 % COMP _____ % GOOD _____ FUNC _____
 EXCEPT (Y) N LUMP SUM: _____
 MISC: _____
 YI CLASS _____ (F) G A E
 SKIRT + LIN FT 131
 COMMENT: _____

TYPE _____
 STAT / CLASS _____
 SIZE _____
 FAIR
 AVERAGE
 GOOD
 EXCELLENT
 BATH _____
 YR BLT _____
 EFF YR _____
 % COMP _____
 EXCEPT Y N

TYPE _____
 STAT / CLASS _____
 SIZE _____
 FAIR
 AVERAGE
 GOOD
 EXCELLENT
 BATH _____
 YR BLT _____
 EFF YR _____
 % COMP _____
 EXCEPT Y N

STAT _____ QLTY + - FLOOR _____
 AREA _____ EFF AREA _____ BED _____
 ROOF + HVAC +
 BATH PKG: _____ BATH _____ BATH + _____ 1/2 BTH
 FIREPLACE: _____
 KITCHEN - +
 YR BLT _____ EFF YR _____ ECON _____
 % COMP _____ % GOOD _____ FUNC _____
 EXCEPT Y N LUMP SUM: _____
 MISC: _____
 YI CLASS _____ F G A E
 SKIRT + LIN FT _____
 COMMENT: _____

TYPE _____
 STAT / CLASS _____
 SIZE _____
 FAIR
 AVERAGE
 GOOD
 EXCELLENT
 BATH _____
 YR BLT _____
 EFF YR _____
 % COMP _____
 EXCEPT Y N

TYPE _____
 STAT / CLASS _____
 SIZE _____
 FAIR
 AVERAGE
 GOOD
 EXCELLENT
 BATH _____
 YR BLT _____
 EFF YR _____
 % COMP _____
 EXCEPT Y N

STAT _____ QLTY + - FLOOR _____
 AREA _____ EFF AREA _____ BED _____
 ROOF + HVAC +
 BATH PKG: _____ BATH _____ BATH + _____ 1/2 BTH
 FIREPLACE: _____
 KITCHEN - +
 YR BLT _____ EFF YR _____ ECON _____
 % COMP _____ % GOOD _____ FUNC _____
 EXCEPT Y N LUMP SUM: _____
 MISC: _____
 YI CLASS _____ F G A E
 SKIRT + LIN FT _____
 COMMENT: _____

TYPE _____
 STAT / CLASS _____
 SIZE _____
 FAIR
 AVERAGE
 GOOD
 EXCELLENT
 BATH _____
 YR BLT _____
 EFF YR _____
 % COMP _____
 EXCEPT Y N

TYPE _____
 STAT / CLASS _____
 SIZE _____
 FAIR
 AVERAGE
 GOOD
 EXCELLENT
 BATH _____
 YR BLT _____
 EFF YR _____
 % COMP _____
 EXCEPT Y N

SKETCH/AREA TABLE ADDENDUM

SUBJECT INFO

File No.: 534890 Parcel No.: 091W18A 01100
 Property Address: 12384 WEST STAYTON ROAD SE
 City: AUMSVILLE County: MARION State: OR ZipCode: 97325
 Owner:
 Client: Client Address:
 Appraiser Name: Inspection Date:

SKETCH

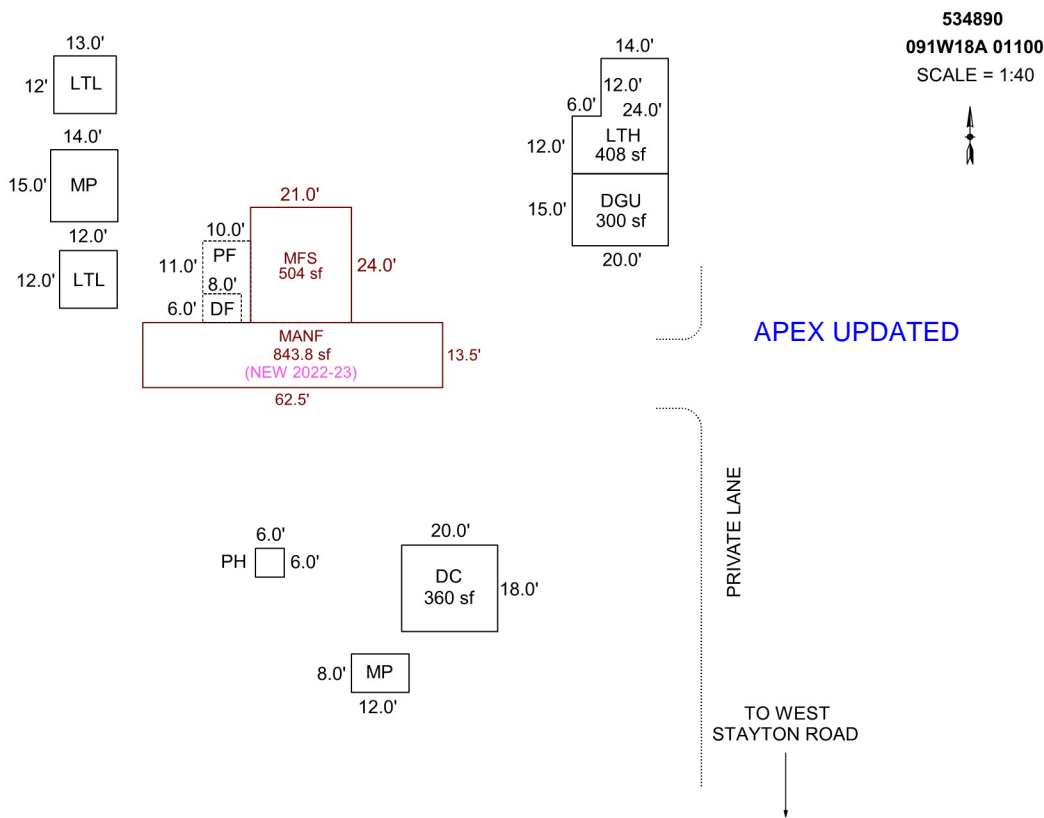

Sketch by Apex Sketch

AREA CALCULATIONS SUMMARY

Code	Description	Factor	Net Size	Perimeter	Net Totals
GBA1	MP	1.0	96.0	40.0	
	LTL	1.0	156.0	50.0	
	PH	1.0	36.0	24.0	
	MP	1.0	210.0	58.0	
	LTH	1.0	408.0	88.0	
	LTL	1.0	144.0	48.0	1050.0
GLA	MANF	1.0	843.8	152.0	843.8
GLA1	MFS	1.0	504.0	90.0	504.0
GAR	DC	1.0	360.0	76.0	
	DGU	1.0	300.0	70.0	660.0
P/P	DF	1.0	48.0	28.0	
	PF	1.0	122.0	54.0	170.0
	Net LIVABLE	cnt	2 (rounded)		1,348
	Net BUILDING	cnt	6 (rounded)		1,050

COMMENT TABLE 1

UPDATED BY CJURAN 12/13/2022 555-22-007647

COMMENT TABLE 2

MNL 4/22/24

COMMENT TABLE 3

LI TAB





11

1/09/23



1/09/23