

Summary Lead Appr: Clerk: Lead Clerk: Appr: MDL Print Date: 7/31/2023

Acct ID: 535175 MTL: 092W07A000600 Date: 1/2/23 Appr: MDL Prop Class: 551 RMV Prop Class: 551
Situs: 10275 PARRISH GAP RD SE TURNER OR 97392 MaSaNh: 07 06 000 Unit: 71385 Year: 2023
Last Date Appraised: 02/04/2015 Appraiser: MATT LORD Retag: N Tag info: 2024 - NEW CONSTRUCTION (Addition)
Owner: MANZO-GARCIA, EULALIO Roll Type: R
Cycle: Tag Sales Verification Other: Inspection level: 1 2 4 LCB TTO INSP AV: 137202
RMV Land: 306630 RMV Imp: 212060 RMV Total: 518690 MAV: 107730 MSAV: 29472 SAV: 42549
Comment:

Notations 23-24: GB ADDITION to existing GB ALIX 22-008288 Nothing started 1/1/25

Table with 3 columns: RP/MS, Code, Description. Row 1: RP, ZONED, FARM EFU ZONED

OSDs

Table with 6 columns: Count, Code, Description, RMV, Code Area, Exception. Row 1: 1, SAA, SA OSD - AVERAGE, 45000, 05590, 0

Land

Site: 2 Code Area: 05590 Size: 1.00 Acres Use Code: 005 Zone: REST SAV Use: 011 Exception: 0
Class: Value Source: Farm Homesite Description: RMV: 22360 Exception: Y N
Adjustment(s): GSOIL Fire Patrol: Description:
Comments: Liability year - 2009 / 00550190
Site: 3 Code Area: 05590 Size: 2.00 Acres Use Code: 005 Zone: REST SAV Use: 011 Exception: 0
Class: 2BD Value Source: Farm Use - EFU Description: TWO BENCH DRY RMV: 49190 Exception: Y N
Adjustment(s): GSOIL Fire Patrol: Description:
Comments: Liability year - 1981 / 00500190 06-19-02: CORR LAND SCHED PER DK #87.
Site: 4 Code Area: 05590 Size: 8.50 Acres Use Code: 005 Zone: REST SAV Use: 011 Exception: 0
Class: 4HD Value Source: Farm Use - EFU Description: FOUR HILL DRY RMV: 190080 Exception: Y N
Adjustment(s): GSOIL Fire Patrol: Description:
Comments: Liability year - 1981 / 00500190: 01-02; CHANGED SOIL CLASS FROM 3 HILL DRY TO 4 HILL DRY

Improvements - Residence / Manufactured Structures

Bldg: 1 Code Area: 05590 Stat Class: 132 Year Blt: 1924 Eff Year Blt: 1935 Sq.Ft: 2100 % Complete: 100
Desc: Multi Story above grade Dimensions: RMV: 192390
Func Obsc: 100 Econ %: 100 Other %: 100 Exception: 0 Adjust: Adjust RMV: 0

Floors

Table with 10 columns: Type, Class, Display Group, Floor Size, Beds, Baths, Yr Blt, Eff Yr Blt, Inventory, Exception. Rows for First Floor, Attic, Carport Attached.

Accessories

Table with 6 columns: Description, Class, Size SqFt, Eff Yr Blt, RMV, Quantity. Rows for ENCLOSED PORCH, YARD IMPROVEMENTS AVERAGE.

Improvements - Accessory Buildings

Bldg: 2 Code Area: 05590 Stat Class: 341 Year Blt: 1962 Eff Year Blt: 1962 Sq.Ft: 96 % Complete: 100
Desc: Multi Purpose Shed (MP) Dimensions: 12x8 RMV: 100
Func Obsc: 100 Econ %: 100 Other %: 100 Exception: 0 Adjust: Adjust RMV: 0

Floors

Table with 10 columns: Type, Class, Display Group, Floor Size, Beds, Baths, Yr Blt, Eff Yr Blt, Inventory, Exception. Row for Multi-Purpose Bldg.

Accessories

No accessory data available

Bldg: 3 Code Area: 05590 Stat Class: 353 Year Blt: 1966 Eff Year Blt: 1966 Sq.Ft: 600 % Complete: 100
Desc: Machine Shed (MS) Dimensions: 30x20 RMV: 1500
Func Obsc: 100 Econ %: 100 Other %: 100 Exception: 0 Adjust: Adjust RMV: 0

Floors

Type	Class	Display Group	Floor Size	Beds	Baths	Yr Blt	Eff Yr Blt	Inventory
Machine Shed	4	Finished	600	0	0	1966	1966	Exception: Y N

Accessories

Description	Class	Size SqFt	Eff Yr Blt	RMV	Quantity
No accessory data available					

Bldg: 4 Code Area: 05590 Stat Class: 351 Year Blt: 1966 Eff Year Blt: 1966 Sq.Ft: 1680 % Complete: 100
 Desc: General Purpose Building (GB) Dimensions: 70x24 RMV: 5090
 Func Obsc: 100 Econ %: 100 Other %: 100 Exception: 0 Adjust: Adjust RMV: 0

Floors

Type	Class	Display Group	Floor Size	Beds	Baths	Yr Blt	Eff Yr Blt	Inventory
General Purpose Bldg	4	Finished	1680	0	0	1966	1966	Exception: Y N

Accessories

Description	Class	Size SqFt	Eff Yr Blt	RMV	Quantity
No accessory data available					

Bldg: 5 Code Area: 05590 Stat Class: 351 Year Blt: 1964 Eff Year Blt: 1964 Sq.Ft: 660 % Complete: 100
 Desc: General Purpose Building (GB) Dimensions: 30x22 RMV: 2680
 Func Obsc: 100 Econ %: 100 Other %: 100 Exception: 0 Adjust: Adjust RMV: 0

Floors

Type	Class	Display Group	Floor Size	Beds	Baths	Yr Blt	Eff Yr Blt	Inventory
General Purpose Bldg	4	Finished	660	0	0	1964	1964	FAIR Exception: Y N

Accessories

Description	Class	Size SqFt	Eff Yr Blt	RMV	Quantity
No accessory data available					

Bldg: 6 Code Area: 05590 Stat Class: 354 Year Blt: 1966 Eff Year Blt: 1966 Sq.Ft: 2172 % Complete: 100
 Desc: Lean-to Light (LTL) Dimensions: 42x16 RMV: 2200
 Func Obsc: 100 Econ %: 100 Other %: 100 Exception: 0 Adjust: Adjust RMV: 0

Floors

Type	Class	Display Group	Floor Size	Beds	Baths	Yr Blt	Eff Yr Blt	Inventory
Lean-to Light Duty	4	Finished	2172	0	0	1966	1966	Exception: Y N

Accessories

Description	Class	Size SqFt	Eff Yr Blt	RMV	Quantity
No accessory data available					

Bldg: 7 Code Area: 05590 Stat Class: 301 Year Blt: Eff Year Blt: Sq.Ft: 64 % Complete: 100
 Desc: Accessory Improvements & Misc. Dimensions: 8x8 RMV: 0
 Func Obsc: 100 Econ %: 100 Other %: 100 Exception: 0 Adjust: Adjust RMV: 0

Floors

Type	Class	Display Group	Floor Size	Beds	Baths	Yr Blt	Eff Yr Blt	Inventory
Pump House	0	Finished	64	0	0	0	0	Exception: Y N

Accessories

Description	Class	Size SqFt	Eff Yr Blt	RMV	Quantity
No accessory data available					

Bldg: 8 Code Area: 05590 Stat Class: 341 Year Blt: 1966 Eff Year Blt: 1966 Sq.Ft: 280 % Complete: 100
 Desc: Multi Purpose Shed (MP) Dimensions: 20x14 RMV: 1470
 Func Obsc: 100 Econ %: 100 Other %: 100 Exception: 0 Adjust: Adjust RMV: 0

Floors

Type	Class	Display Group	Floor Size	Beds	Baths	Yr Blt	Eff Yr Blt	Inventory
Multi-Purpose Bldg	5	Finished	280	0	0	1966	1966	Exception: Y N

Accessories

Description	Class	Size SqFt	Eff Yr Blt	RMV	Quantity
No accessory data available					

Bldg: 9 Code Area: 05590 Stat Class: 353 Year Blt: 1966 Eff Year Blt: 1966 Sq.Ft: 1440 % Complete: 100
 Desc: Machine Shed (MS) Dimensions: 60x24 RMV: 5050
 Func Obsc: 100 Econ %: 100 Other %: 100 Exception: 0 Adjust: Adjust RMV: 0

Floors

Type	Class	Display Group	Floor Size	Beds	Baths	Yr Blt	Eff Yr Blt	Inventory
Machine Shed	5	Finished	1440	0	0	1966	1966	Exception: Y N

Accessories

Description	Class	Size SqFt	Eff Yr Blt	RMV	Quantity
No accessory data available					

Bldg: 10 Code Area: 05590 Stat Class: 353 Year Blt: 1966 Eff Year Blt: 1966 Sq.Ft: 360 % Complete: 100
 Desc: Machine Shed (MS) Dimensions: 30x12 RMV: 1580
 Func Obsc: 100 Econ %: 100 Other %: 100 Exception: 0 Adjust: Adjust RMV: 0

Floors

Type	Class	Display Group	Floor Size	Beds	Baths	Yr Blt	Eff Yr Blt	Inventory
Machine Shed	5	Finished	360	0	0	1966	1966	Exception: Y N

Accessories

Description	Class	Size SqFt	Eff Yr Blt	RMV	Quantity
No accessory data available					

SKETCH/AREA TABLE ADDENDUM

SUBJECT INFO

File No.: 535175 Parcel No.: 092W07A 00600
 Property Address: 10275 PARRISH GAP RD SE
 City: TURNER County: MARION State: OR ZipCode: 97392
 Owner:
 Client: Client Address:
 Appraiser Name: Inspection Date:

SKETCH

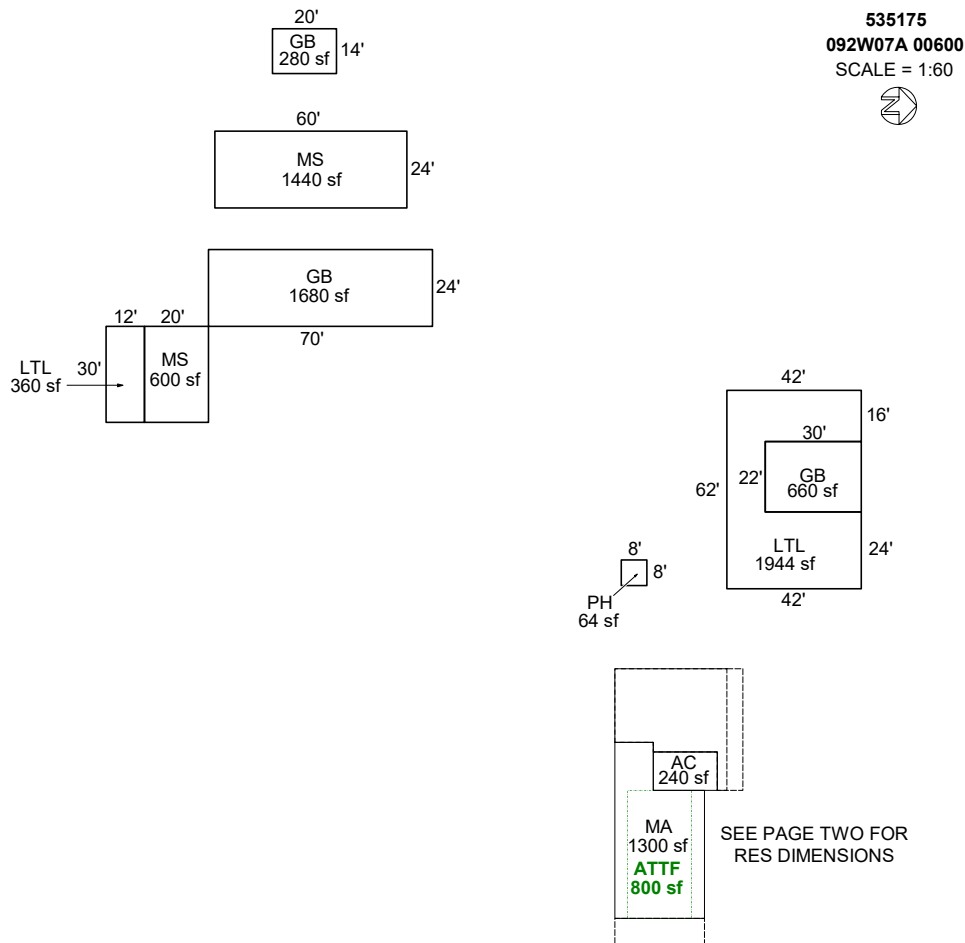

SEE PAGE TWO FOR
RES DIMENSIONS

Sketch by Apex Sketch

AREA CALCULATIONS SUMMARY						COMMENT TABLE 1	
Code	Description	Factor	Net Size	Perimeter	Net Totals		
GBA1	MS	1.0	600.0	100.0		APEXED BY NRC 10/19/2009 UPDATED BY CJURAN 03/12/2024	
	GB	1.0	1680.0	188.0			
	MS	1.0	1440.0	168.0			
	GB	1.0	660.0	104.0			
	LTL	1.0	1944.0	268.0			
	GB	1.0	280.0	68.0			
	LTL	1.0	360.0	84.0			
	PH	1.0	64.0	32.0	7028.0		
GLA1	MA	1.0	1300.0	166.0	1300.0		
ATTF	ATTF	1.0	800.0	120.0	800.0		
GAR	AC	1.0	240.0	64.0	240.0	COMMENT TABLE 2	COMMENT TABLE 3
P/P	EP	1.0	224.0	72.0		MDL 01/02/2023	TAGS L3
	PF	1.0	910.0	146.0			
	PC	1.0	1100.0	156.0	2234.0		
	Net LIVABLE	cnt	1 (rounded)		1,300		
	Net BUILDING	cnt	8 (rounded)		7,028		

SKETCH/AREA TABLE ADDENDUM

SUBJECT INFO

File No.: 535175 Parcel No.: 092W07A 00600
 Property Address: 10275 PARRISH GAP RD SE
 City: TURNER County: MARION State: OR ZipCode: 97392
 Owner:
 Client: Client Address:
 Appraiser Name: Inspection Date:

SKETCH

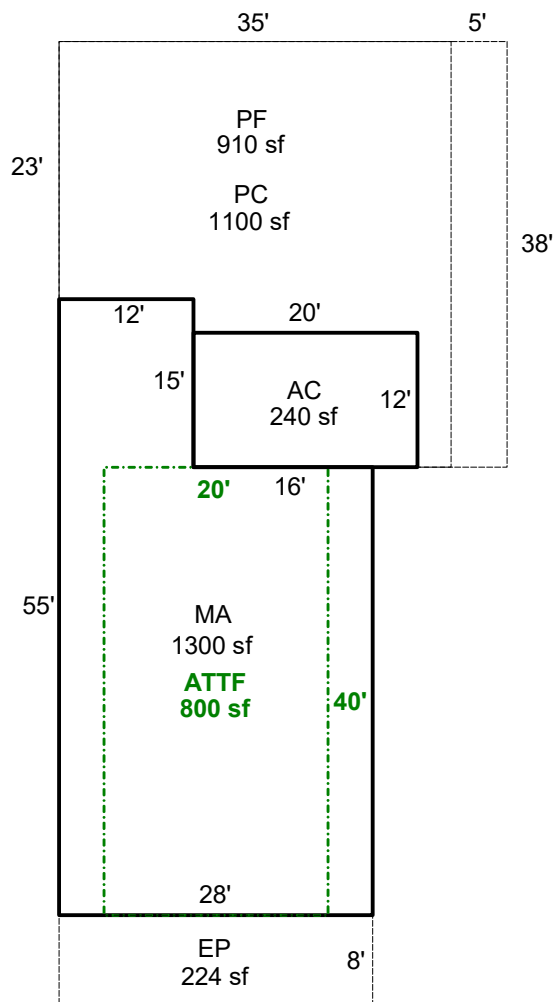

535175
092W07A 00600
 SCALE = 1:20



Sketch by Apex Sketch

AREA CALCULATIONS SUMMARY						COMMENT TABLE 1		
Code	Description	Factor	Net Size	Perimeter	Net Totals			
GLA1	MA	1.0	1300.0	166.0	1300.0	APEXED BY NRC 10/19/2009 UPDATED BY CJURAN 03/12/2024		
ATTF	ATTF	1.0	800.0	120.0	800.0			
GAR	AC	1.0	240.0	64.0	240.0			
P/P	EP	1.0	224.0	72.0				
	PF	1.0	910.0	146.0				
	PC	1.0	1100.0	156.0	2234.0			
Net LIVABLE						cnt	1 (rounded)	1,300
						COMMENT TABLE 2	COMMENT TABLE 3	
						MDL 01/02/2023	TAGS L3	

092W07A 00600

R35175

SEE PAGE TWO FOR HOME DIMENSIONS

SCALE=1/8"



UPDATE APEX
IN NEWER PROGRAM
MAY NOT MATCH WHAT
WE HAVE IN THE SYSTEM

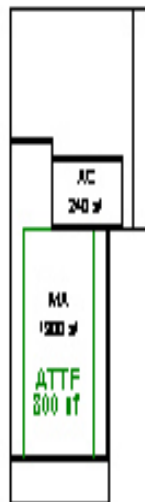
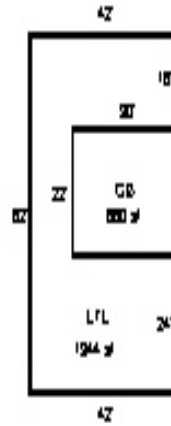
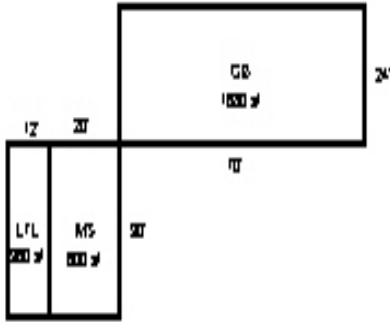
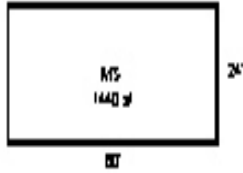

092W07A 00600

R35175

SEE PAGE ONE FOR ALL BUILDINGS

SCALE=1/2"

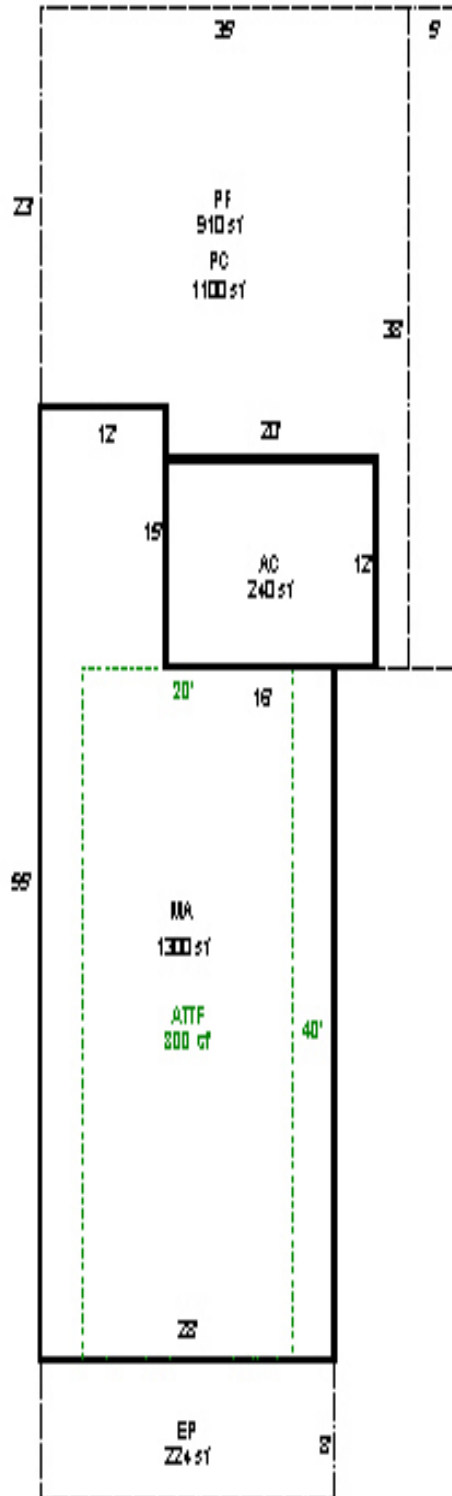



STONIA TIRE BIRD W
10275

R35175

01-6-2013



R35175Hay

01-6-2013



R35175cows

01-6-2013











