

Acct ID: 535573 MTL: 092W23A000800 Date: 2/15/24 Appr: MDL Prop Class: 581 RMV Prop Class: 401  
 Situs: 12244 BRICK RD SE TURNER OR 97392 MaSaNh: 07 06 000 Unit: 61357 Year: 2024

Last Date Appraised: 05/08/2020 Appraiser: MATT LORD Retag: Y N Tag info: 2024 - Tags/Permit (Alt Energy System)

Owner: EFU TR & BEININGEN, CYNTHIA J TRE & Roll Type: R  
 Cycle Tag Sales Verification Other: \_\_\_\_\_ Inspection level: 1 2 3 4 LCB TTO INSP AV: 233906

RMV Land: 333180 RMV Imp: 295200 RMV Total: 628380 MAV: 226520 MSAV: 7386 SAV: 15784

Comment: 23-004774 32 panels \$11,550 solar

**Notations**

RP/MS	Code	Description
RP	FUZ	FARM NON-EFU ZONED

**OSDs**

Count	Code	Description	RMV	Code Area	Exception
1	MKTA	OSD - AVERAGE	45000	05545	0

**Land**

Site: 1 Code Area: 05545 Size: 1.00 Acres Use Code: 004 Zone: NREST SAV Use: Exception: 0  
 Class: 4BDS Value Source: Market Homesite Description: FOUR BENCH DRY SPECIAL SOUTH RMV: 30210 Exception: Y N  
 S  
 Adjustment(s): Fire Patrol: Description:  
 Comments: 02-03: REAPPRAISAL 06-07: DISQUALIFYING OSD'S FROM SPEC ASSESS IN UZ FARMLAND THAT DO NOT MEET THE NEW REQUIREMENTS. POSTING EXCEPTION W/NO RECAPTURE OF TAXES. 550040 //2-16-07 (GW39): Change from 008 to 007.

Site: 2 Code Area: 05545 Size: 2.04 Acres Use Code: 004 Zone: NREST SAV Use: 011 Exception: 0  
 Class: 4BDS Value Source: Farm Use - Non EFU Description: FOUR BENCH DRY SPECIAL SOUTH RMV: 61620 Exception: Y N  
 S  
 Adjustment(s): Fire Patrol: Description:  
 Comments: Liability year - 1982 / 550040 //04-05: ADJUSTMENT OF LAND SCHEDULE FOR RECALCULATION BY #36 5-4-04

Site: 3 Code Area: 05545 Size: 1.50 Acres Use Code: 004 Zone: NREST SAV Use: 011 Exception: 0  
 Class: 4BDS Value Source: Woodlot Description: FOUR BENCH DRY SPECIAL SOUTH RMV: 45310 Exception: Y N  
 S  
 Adjustment(s): Fire Patrol: Description:  
 Comments: Liability year - 1982 / 550040 //04-05: ADJUSTMENT OF LAND SCHEDULE FOR RECALCULATION BY #36 5-4-04

Site: 4 Code Area: 05545 Size: 5.00 Acres Use Code: 004 Zone: REST SAV Use: 011 Exception: 0  
 Class: 4BDS Value Source: Farm Use - EFU Description: FOUR BENCH DRY SPECIAL SOUTH RMV: 151040 Exception: Y N  
 S  
 Adjustment(s): Fire Patrol: Description:  
 Comments: 550040 //04-05: ADJUSTMENT OF LAND SCHEDULE FOR RECALCULATION BY #36 5-4-04

**Improvements - Residence / Manufactured Structures**

Bldg: 1 Code Area: 05545 Stat Class: 131 + Year Blt: 1947 Eff Year Blt: 1989 Sq.Ft: 1824 % Complete: 100  
 Desc: One Story Only Dimensions: RMV: 191490  
 Func Obsc: 100 Econ %: 100 Other %: 100 Exception: 0 Adjust: Adjust RMV: 0

**Floors**

Type	Class	Display Group	Floor Size	Beds	Baths	Yr Blt	Eff Yr Blt	Inventory	Exception
First Floor	3 +	Finished	1824	2	FB-2	1947	1989	FP, HVAC, ROOF, KIT, BATH - 2	Y N

**Accessories**

Description	Class	Size SqFt	Eff Yr Blt	RMV	Quantity	Exception
PATIO	3	528	1989	2410	1	Y N
ROOF EXTENSION OR PATIO COVER	3	528	1989	12709	1	Y N

Bldg: 2 Code Area: 05545 Stat Class: 138 Year Blt: 1947 Eff Year Blt: 1947 Sq.Ft: 0 % Complete: 100  
 Desc: Res other improvements Dimensions: RMV: 33870  
 Func Obsc: 100 Econ %: 100 Other %: 100 Exception: 0 Adjust: Adjust RMV: 0

**Floors**

Type	Class	Display Group	Floor Size	Beds	Baths	Yr Blt	Eff Yr Blt	Inventory	Exception
Garage Oversized Detached	3	Unfinished	1000	0	0	1947	1947	ROOF	Y N

**Accessories**

Description	Class	Size SqFt	Eff Yr Blt	RMV	Quantity
No accessory data available					

**Improvements - Accessory Buildings**

Bldg: 3 Code Area: 05545 Stat Class: 354 Year Blt: Eff Year Blt: Sq.Ft: 128 % Complete: 100  
 Desc: Lean-to Light (LTL) Dimensions: 16x8 RMV: 520  
 Func Obsc: 100 Econ %: 100 Other %: 100 Exception: 0 Adjust: Adjust RMV: 0

**Floors**

Type	Class	Display Group	Floor Size	Beds	Baths	Yr Blt	Eff Yr Blt	Inventory	
Lean-to Light Duty	4	Finished	128	0	0	0	0		Exception: Y N

**Accessories**

Description	Class	Size SqFt	Eff Yr Blt	RMV	Quantity
No accessory data available					

Bldg: 4 Code Area: 05545 Stat Class: 301 Year Blt: Eff Year Blt: Sq.Ft: 120 % Complete: 100  
 Desc: Accessory Improvements & Misc. Dimensions: 12x10 RMV: 0  
 Func Obsc: 100 Econ %: 100 Other %: 100 Exception: 0 Adjust: Adjust RMV: 0

**Floors**

Type	Class	Display Group	Floor Size	Beds	Baths	Yr Blt	Eff Yr Blt	Inventory	
Pump House	0	Finished	120	0	0	0	0		Exception: Y N

**Accessories**

Description	Class	Size SqFt	Eff Yr Blt	RMV	Quantity
No accessory data available					

Bldg: 5 Code Area: 05545 Stat Class: 351 Year Blt: 1999 Eff Year Blt: 1999 Sq.Ft: 2304 % Complete: 100  
 Desc: General Purpose Building (GB) Dimensions: 36x48 RMV: 27720  
 Func Obsc: 100 Econ %: 100 Other %: 100 Exception: 0 Adjust: Adjust RMV: 0

**Floors**

Type	Class	Display Group	Floor Size	Beds	Baths	Yr Blt	Eff Yr Blt	Inventory	
Attic	5	Finished	576	0	0	1999	1999		Exception: Y N
General Purpose Bldg	5	Finished	1728	0	0	1999	1999	FAIR	Exception: Y N

**Accessories**

Description	Class	Size SqFt	Eff Yr Blt	RMV	Quantity
No accessory data available					

Bldg: 6 Code Area: 05545 Stat Class: 353 Year Blt: 2000 Eff Year Blt: 2000 Sq.Ft: 480 % Complete: 100  
 Desc: Machine Shed (MS) Dimensions: 24x20 RMV: 4550  
 Func Obsc: 100 Econ %: 100 Other %: 100 Exception: 0 Adjust: Adjust RMV: 0

**Floors**

Type	Class	Display Group	Floor Size	Beds	Baths	Yr Blt	Eff Yr Blt	Inventory	
Machine Shed	5	Finished	480	0	0	2000	2000		Exception: Y N

**Accessories**

Description	Class	Size SqFt	Eff Yr Blt	RMV	Quantity
No accessory data available					

Bldg: 7 Code Area: 05545 Stat Class: 321 Year Blt: 2001 Eff Year Blt: 2001 Sq.Ft: 8880 % Complete: 100  
 Desc: Hay Cover (HC) Dimensions: 74x120 RMV: 31820  
 Func Obsc: 100 Econ %: 100 Other %: 100 Exception: 0 Adjust: Adjust RMV: 0

**Floors**

Type	Class	Display Group	Floor Size	Beds	Baths	Yr Blt	Eff Yr Blt	Inventory	
Hay Cover	5	Finished	8880	0	0	2001	2001		Exception: Y N

**Accessories**

Description	Class	Size SqFt	Eff Yr Blt	RMV	Quantity
No accessory data available					

Bldg: 8 Code Area: 05545 Stat Class: 355 Year Blt: 2000 Eff Year Blt: 2000 Sq.Ft: 336 % Complete: 100  
 Desc: Lean-to Heavy (LTH) Dimensions: 14x24 RMV: 1470  
 Func Obsc: 100 Econ %: 100 Other %: 100 Exception: 0 Adjust: Adjust RMV: 0

**Floors**

Type	Class	Display Group	Floor Size	Beds	Baths	Yr Blt	Eff Yr Blt	Inventory	
Lean-to Heavy Duty	4	Finished	336	0	0	2000	2000	FAIR	Exception: Y N

**Accessories**

Description	Class	Size SqFt	Eff Yr Blt	RMV	Quantity
No accessory data available					

Bldg: 9 Code Area: 05545 Stat Class: 341 Year Blt: 2008 Eff Year Blt: 2008 Sq.Ft: 320 % Complete: 100

Desc: Multi Purpose Shed (MP)

Dimensions: 16x20

RMV: 3760

Func Obsc: 100

Econ %: 100

Other %: 100

Exception: 0

Adjust:

Adjust RMV: 0

**Floors**

Type	Class	Display Group	Floor Size	Beds	Baths	Yr Blt	Eff Yr Blt	Inventory
Multi-Purpose Bldg	4	Finished	320	0	0	2008	2008	Exception: Y N

**Accessories**

Description	Class	Size SqFt	Eff Yr Blt	RMV	Quantity
No accessory data available					

R35573  
092W23A 00800  
SCALE=1:60

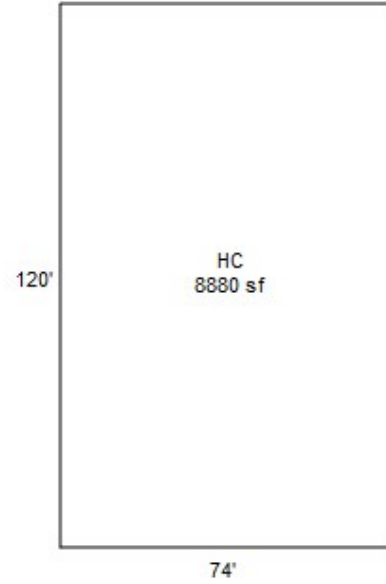

APEX UPDATED

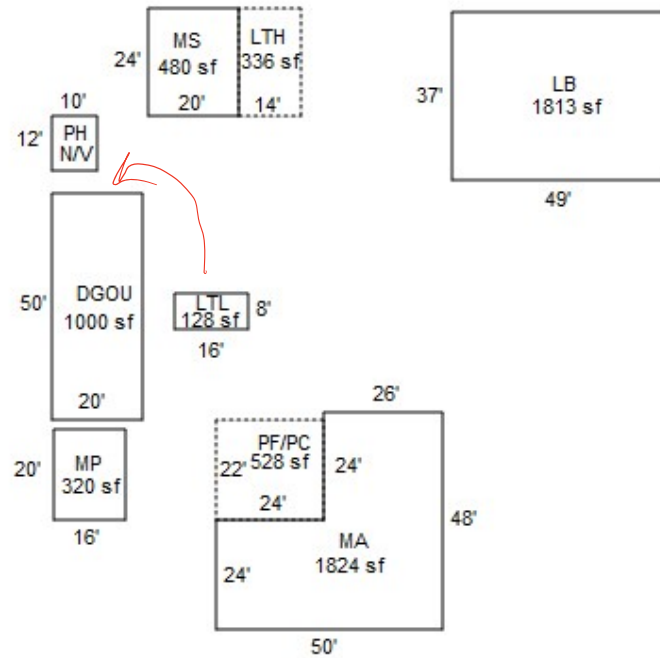

Mbord 2/15/24  
LH TAB

