

Acct ID: 536319 MTL: 093W130000800 Date: 2/6/24 Appr: MDL Prop Class: 451 RMV Prop Class: 451
 Situs: 11504 SUMMIT LOOP SE TURNER OR 97392 MaSaNh: 07 06 002 Unit: 25352 Year: 2023



Last Date Appraised: 04/25/2019 Appraiser: MATT LORD Retag: Y N Tag info: 2024 - Tags/Permit (Addition)
 Owner: BRAY, RENE ALAINA Roll Type: R
 Cycle: Tag Sales Verification Other: _____ Inspection level: 1 2 3 4 LCB TTO INSP AV: 408290
 RMV Land: 251020 RMV Imp: 568500 RMV Total: 819520 MAV: 408290 MSAV: 0 SAV: 0
 Comment: Exception

Notations 24-25: 703 sqft 1BD 1BA addition (22-008446) 100% complete Pull TAB

OSDs

Count	Code	Description	RMV	Code Area	Exception
1	MKTG	OSD - GOOD	55000	05590	0

Land

Site: 1 Code Area: 05590 Size: 3.53 Acres Use Code: 005 Zone: REST SAV Use: Exception: 0
 Class: Value Source: Rural Restrictive Description: RMV: 196020 Exception: Y N
 Adjustment(s): VWAR Fire Patrol: Description:
 Comments: 00-01; REAPPRAISAL

Improvements - Residence / Manufactured Structures

Bldg: 1 Code Area: 05590 Stat Class: 152 Year Blt: 1989 Eff Year Blt: 1992 Sq.Ft: 2071 % Complete: 100
 Desc: Multi Story above grade Dimensions: RMV: 511870
 Func Obsc: 100 Econ %: 100 Other %: 100 Exception: 0 Adjust: Adjust RMV: 0

Floors

Type	Class	Display Group	Floor Size	Beds	Baths	Yr Blt	Eff Yr Blt	Inventory	Exception
First Floor	5	Finished	1436	1	FB-1/ HB-1	1989	1992	ROOF, FP, HVAC+, KIT+, BATH - 1, BTH - 1	Exception: Y N
Second Floor	5	Finished	635	2	FB-1	1989	1992	HVAC+, ROOF, BATH - 1	Exception: Y N
Garage Attached	5	Finished	594	0	0	1989	1992	ROOF	Exception: Y N
Garage Detached	3	Unfinished	280	0	0	1989	1989	ROOF	Exception: Y N

Accessories

Description	Class	Size SqFt	Eff Yr Blt	RMV	Quantity	Exception
ASPHALT DRIVEWAY	5	3535	1992	9014	1	Exception: Y N
DECK	5	602	1992	10234	1	Exception: Y N
PATIO	5	155	1992	724	1	Exception: Y N
ROOF EXTENSION OR PATIO COVER	5	20	1992	493	1	Exception: Y N

Bldg: 6 Code Area: 05590 Stat Class: 108 Year Blt: 2006 Eff Year Blt: 2006 Sq.Ft: 0 % Complete: 100
 Desc: Residential Other Improvements Dimensions: RMV: 7090
 Func Obsc: 100 Econ %: 100 Other %: 100 Exception: 0 Adjust: Adjust RMV: 0

Floors

Type	Class	Display Group	Floor Size	Beds	Baths	Yr Blt	Eff Yr Blt	Inventory	Exception
No floor data available									

Accessories

Description	Class	Size SqFt	Eff Yr Blt	RMV	Quantity	Exception
GARDEN GREENHOUSE	1	144	2006	5670	1	Exception: Y N

Improvements - Accessory Buildings

Bldg: 2 Code Area: 05590 Stat Class: 341 Year Blt: 1989 Eff Year Blt: 1984 Sq.Ft: 180 % Complete: 100
 Desc: Multi Purpose Shed (MP) Dimensions: 18x10 RMV: 1170
 Func Obsc: 100 Econ %: 100 Other %: 100 Exception: 0 Adjust: Adjust RMV: 0

Floors

Type	Class	Display Group	Floor Size	Beds	Baths	Yr Blt	Eff Yr Blt	Inventory	Exception
Multi-Purpose Bldg	4	Finished	180	0	0	1989	1984	FAIR	Exception: Y N

Accessories

Description	Class	Size SqFt	Eff Yr Blt	RMV	Quantity	Exception
No accessory data available						

Bldg: 3 Code Area: 05590 Stat Class: 351 Year Blt: 2000 Eff Year Blt: 2000 Sq.Ft: 1995 % Complete: 100
 Desc: General Purpose Building (GB) Dimensions: 38x48 RMV: 39170
 Func Obsc: 100 Econ %: 100 Other %: 100 Exception: 0 Adjust: Adjust RMV: 0

Floors

Type	Class	Display Group	Floor Size	Beds	Baths	Yr Blt	Eff Yr Blt	Inventory	Exception: Y N
General Purpose Bldg	6	Finished	1824	0	0	2000	2000	AVG	Exception: Y N
Finished Office	6	Finished	171	0	FB-1/ HB-1	2000	2000	BTH - 1	Exception: Y N

Accessories

Description	Class	Size SqFt	Eff Yr Blt	RMV	Quantity
No accessory data available					

Bldg: 4 Code Area: 05590 Stat Class: 351 Year Blt: 2000 Eff Year Blt: 2004 Sq.Ft: 576 % Complete: 100
 Desc: General Purpose Building (GB) Dimensions: 12x48 RMV: 7260
 Func Obsc: 100 Econ %: 100 Other %: 100 Exception: 0 Adjust: Adjust RMV: 0

Floors

Type	Class	Display Group	Floor Size	Beds	Baths	Yr Blt	Eff Yr Blt	Inventory	Exception: Y N
General Purpose Bldg	4	Finished	576	0	0	2000	2004	FAIR	Exception: Y N

Accessories

Description	Class	Size SqFt	Eff Yr Blt	RMV	Quantity
No accessory data available					

Bldg: 5 Code Area: 05590 Stat Class: 341 Year Blt: 1992 Eff Year Blt: 1992 Sq.Ft: 170 % Complete: 100
 Desc: Multi Purpose Shed (MP) Dimensions: 10x17 RMV: 1580
 Func Obsc: 100 Econ %: 100 Other %: 100 Exception: 0 Adjust: Adjust RMV: 0

Floors

Type	Class	Display Group	Floor Size	Beds	Baths	Yr Blt	Eff Yr Blt	Inventory	Exception: Y N
Multi-Purpose Bldg	4	Finished	170	0	0	1992	1992		Exception: Y N

Accessories

Description	Class	Size SqFt	Eff Yr Blt	RMV	Quantity
No accessory data available					

Bldg: 7 Code Area: 05590 Stat Class: 341 Year Blt: 2017 Eff Year Blt: 2017 Sq.Ft: 100 % Complete: 100
 Desc: Multi Purpose Shed (MP) Dimensions: 10x10 RMV: 0
 Func Obsc: 100 Econ %: 100 Other %: 100 Exception: 0 Adjust: Adjust RMV: 0

Floors

Type	Class	Display Group	Floor Size	Beds	Baths	Yr Blt	Eff Yr Blt	Inventory	Exception: Y N
Multi-Purpose Bldg	5	Finished	100	0	0	2017	2017		Exception: Y N

Accessories

Description	Class	Size SqFt	Eff Yr Blt	RMV	Quantity
No accessory data available					

Bldg: 8 Code Area: 05590 Stat Class: 354 Year Blt: 2017 Eff Year Blt: 2017 Sq.Ft: 80 % Complete: 100
 Desc: Lean-to Light (LTL) Dimensions: 8x10 RMV: 360
 Func Obsc: 100 Econ %: 100 Other %: 100 Exception: 0 Adjust: Adjust RMV: 0

Floors

Type	Class	Display Group	Floor Size	Beds	Baths	Yr Blt	Eff Yr Blt	Inventory	Exception: Y N
Lean-to Light Duty	4	Finished	80	0	0	2017	2017		Exception: Y N

Accessories

Description	Class	Size SqFt	Eff Yr Blt	RMV	Quantity
No accessory data available					

ACCOUNT # 536319 DATE: 2/6/24 RMV CLASS _____ PROP CLASS _____
 MTL 93W 13 800 APPR MA TAG Y (N)
 COMMENTS: _____

RESIDENCE / MANUFACTURED STRUCTURES

ACCESSORY IMPROVEMENTS / OUTBUILDINGS

STAT 5 QLTY + - FLOOR MA
 AREA 715 EFF AREA 715 BED 1
 ROOF + HVAC +
 BATH PKG: _____ BATH 1 BATH + _____ 1/2 BTH
 FIREPLACE: _____
 KITCHEN - +
 YR BLT 2023 EFF YR 2023 ECON _____
 % COMP _____ % GOOD _____ FUNC _____
 EXCEPT (Y) N LUMP SUM: _____
 MISC: _____
 YI CLASS _____ F G A E
 SKIRT + LIN FT _____
 COMMENT: _____

TYPE _____
 STAT / CLASS _____
 SIZE _____
 FAIR
 AVERAGE
 GOOD
 EXCELLENT
 BATH _____
 YR BLT _____
 EFF YR _____
 % COMP _____
 EXCEPT Y N
 MISC: _____
 COMMENT: _____

TYPE _____
 STAT / CLASS _____
 SIZE _____
 FAIR
 AVERAGE
 GOOD
 EXCELLENT
 BATH _____
 YR BLT _____
 EFF YR _____
 % COMP _____
 EXCEPT Y N
 MISC: _____
 COMMENT: _____

STAT _____ QLTY + - FLOOR _____
 AREA _____ EFF AREA _____ BED _____
 ROOF + HVAC +
 BATH PKG: _____ BATH _____ BATH + _____ 1/2 BTH
 FIREPLACE: _____
 KITCHEN - +
 YR BLT _____ EFF YR _____ ECON _____
 % COMP _____ % GOOD _____ FUNC _____
 EXCEPT Y N LUMP SUM: _____
 MISC: _____
 YI CLASS _____ F G A E
 SKIRT + LIN FT _____
 COMMENT: _____

TYPE _____
 STAT / CLASS _____
 SIZE _____
 FAIR
 AVERAGE
 GOOD
 EXCELLENT
 BATH _____
 YR BLT _____
 EFF YR _____
 % COMP _____
 EXCEPT Y N
 MISC: _____
 COMMENT: _____

TYPE _____
 STAT / CLASS _____
 SIZE _____
 FAIR
 AVERAGE
 GOOD
 EXCELLENT
 BATH _____
 YR BLT _____
 EFF YR _____
 % COMP _____
 EXCEPT Y N
 MISC: _____
 COMMENT: _____

STAT _____ QLTY + - FLOOR _____
 AREA _____ EFF AREA _____ BED _____
 ROOF + HVAC +
 BATH PKG: _____ BATH _____ BATH + _____ 1/2 BTH
 FIREPLACE: _____
 KITCHEN - +
 YR BLT _____ EFF YR _____ ECON _____
 % COMP _____ % GOOD _____ FUNC _____
 EXCEPT Y N LUMP SUM: _____
 MISC: _____
 YI CLASS _____ F G A E
 SKIRT + LIN FT _____
 COMMENT: _____

TYPE _____
 STAT / CLASS _____
 SIZE _____
 FAIR
 AVERAGE
 GOOD
 EXCELLENT
 BATH _____
 YR BLT _____
 EFF YR _____
 % COMP _____
 EXCEPT Y N
 MISC: _____
 COMMENT: _____

TYPE _____
 STAT / CLASS _____
 SIZE _____
 FAIR
 AVERAGE
 GOOD
 EXCELLENT
 BATH _____
 YR BLT _____
 EFF YR _____
 % COMP _____
 EXCEPT Y N
 MISC: _____
 COMMENT: _____

SKETCH/AREA TABLE ADDENDUM

SUBJECT INFO

File No.: 536319 Parcel No.: 093W13 00800
 Property Address: 11504 SUMMIT LP SE
 City: TURNER County: MARION State: OR ZipCode: 97392
 Owner:
 Client: Client Address:
 Appraiser Name: Inspection Date:

SKETCH

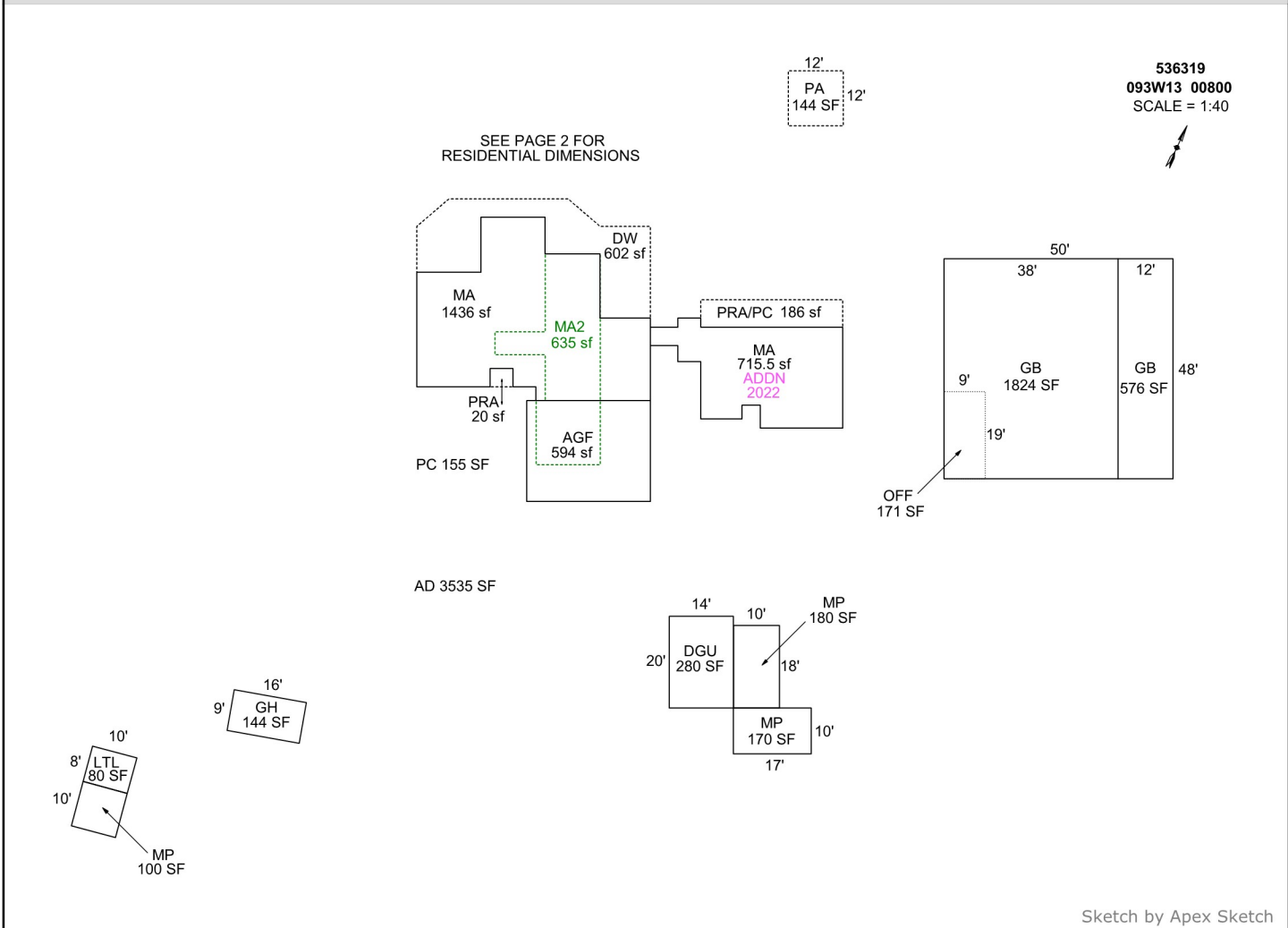

AREA CALCULATIONS SUMMARY

COMMENT TABLE 1

Code	Description	Factor	Net Size	Perimeter	Net Totals
GBA1	GB	1.0	1824.0	172.0	
	GH	1.0	144.0	50.0	
	LTL	1.0	80.0	36.0	
	MP	1.0	100.0	40.0	
	MP	1.0	170.0	54.0	
	MP	1.0	180.0	56.0	
	GB	1.0	576.0	120.0	3074.0
GLA1	MA	1.0	1436.0	190.0	
	MA	1.0	715.5	138.0	2151.5
GLA2	MA2	1.0	635.0	142.0	635.0
GAR	DGU	1.0	280.0	68.0	
	AGF	1.0	594.0	98.0	874.0
OTH	OFF	1.0	171.0	56.0	171.0
P/P	DW	1.0	602.0	170.4	
	PA	1.0	144.0	48.0	
	PRA/PC	1.0	186.0	74.0	
	1 addl items				
	Net LIVABLE	cnt	3 (rounded)		2,787
	Net BUILDING	cnt	7 (rounded)		3,074

UPD BY NMM 04.29.19
 UPDATED BY CJURAN 12/27/2022 555-22-008446

COMMENT TABLE 2

COMMENT TABLE 3

SKETCH/AREA TABLE ADDENDUM

SUBJECT INFO

File No.: 536319 Parcel No.: 093W13 00800
 Property Address: 11504 SUMMIT LP SE
 City: TURNER County: MARION State: OR ZipCode: 97392
 Owner:
 Client: Client Address:
 Appraiser Name: Inspection Date:

SKETCH

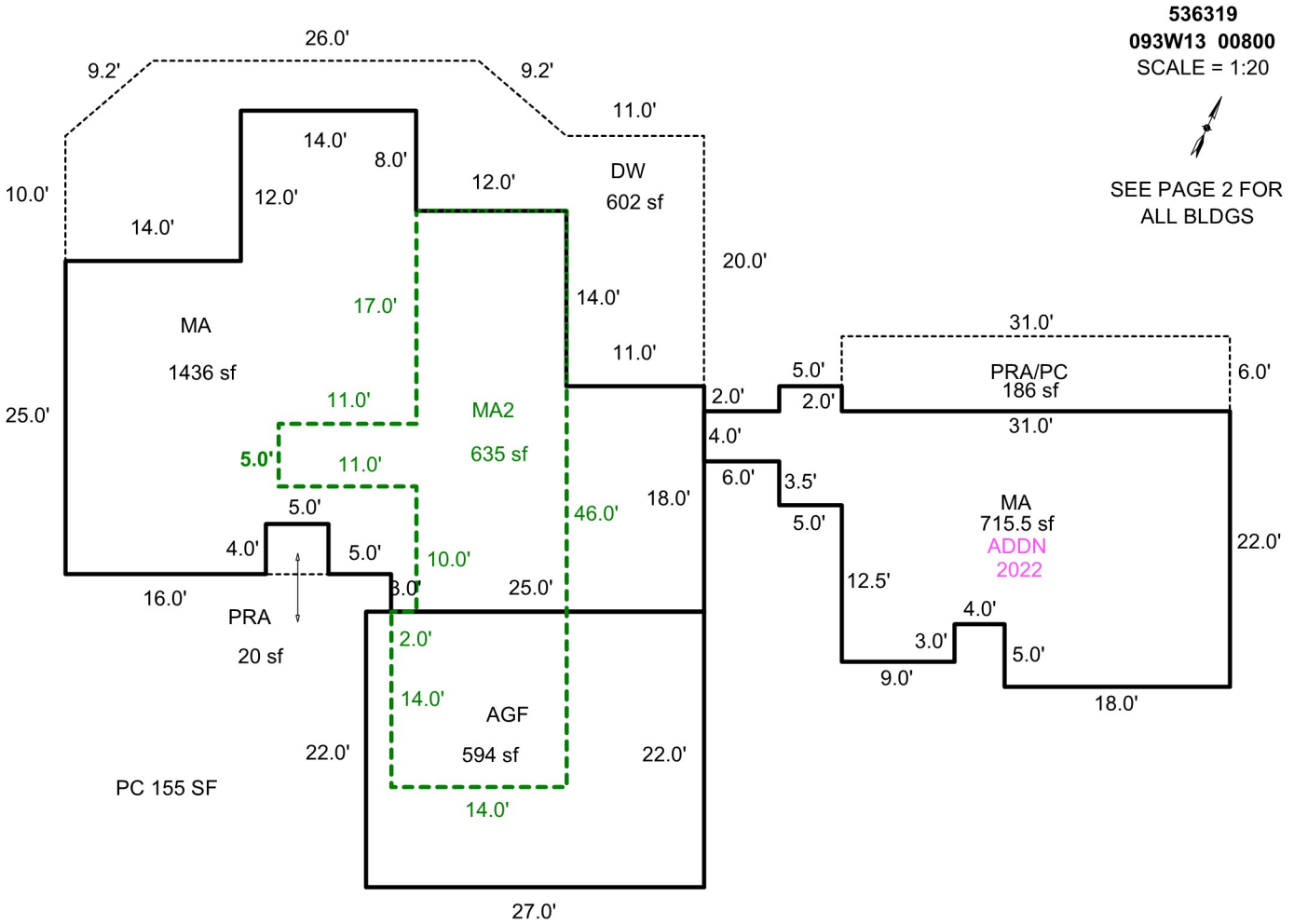

AREA CALCULATIONS SUMMARY

Code	Description	Factor	Net Size	Perimeter	Net Totals
GLA1	MA	1.0	715.5	138.0	
	MA	1.0	1436.0	190.0	2151.5
GLA2	MA2	1.0	635.0	142.0	635.0
GAR	AGF	1.0	594.0	98.0	594.0
P/P	PRA/PC	1.0	186.0	74.0	
	DW	1.0	602.0	170.4	
	PRA	1.0	20.0	18.0	808.0

COMMENT TABLE 1

UPD BY NMM 04.29.19
 UPDATED BY CJURAN 12/27/2022 555-22-008446

COMMENT TABLE 2

COMMENT TABLE 3

Net LIVABLE cnt 3 (rounded) 2,787



R36319 AD 04.25.19



R36319 AGF 04.25.19



36319 CHICKEN COOP 04.25.1



R36319 DGU REAR MP 04.25.19



R36319 DGU SIDE 04.25.19



R36319 GAZEBO 04.25.19



R36319 GB FRONT 04.25.19



R36319 GB N SIDE 04.25.19



R36319 GB S SIDE 04.25.19



R36319 GH 04.25.19



R36319 MA E SIDE 04.25.19



6319 MA FRONT DOOR 04.25.



R36319 MA FRONT 04.25.19



R36319 MA REAR 04.25.19



R36319 MA W SIDE 04.25.19



R36319 RER MP 04.25.19



R36319 STUDIO TWO 04.25.19



R36319 TANK 04.25.19



R36319 VIEW GAZEBO 04.25.19



R36319 VIEW 04.25.19



6319 WATER FEATURE 04.25.





2/6/24

