

Acct ID: 536612 MTL: 093W280000900 Date: 11/24/23 Appr: MDL Prop Class: 551 RMV Prop Class: 551
 Situs: 1786 TALBOT RD S JEFFERSON OR 97352 MaSaNh: 07 06 000 Unit: 145316 Year: 2024

Last Date Appraised: 11/24/2009 Appraiser: MATT LORD Retag: Y N Tag info: _____

Owner: JENSEN SISTERS HOLDINGS LLC Roll Type: R

Cycle Tag Sales Verification Other: _____ Inspection level: 1 2 3 4 LCB TTO INSP AV: 740204

RMV Land: 756650 RMV Imp: 803500 RMV Total: 1560150 MAV: 430730 MSAV: 309734 SAV: 992820

Comment: _____ 20 ✓

Notations NO changes NOT ON the OPEN Market

RP/MS	Code	Description
RP	ZONED	FARM EFU ZONED

Workflow was closed - created new. WW 4.16.24

OSDs

Count	Code	Description	RMV	Code Area	Exception
1	SAA	SA OSD - AVERAGE	45000	14530	0

Land

Site: 2 Code Area: 14530 Size: 1.00 Acres Use Code: 005 Zone: REST SAV Use: 011 Exception: 0
 Class: Value Source: Farm Homesite Description: RMV: 2750 Exception: Y N
 Adjustment(s): GSOIL, WASTE, IRR Fire Patrol: Description:
 Comments: Liability year - 2009 / 00-01; UPDATED MARKET VALUE, 81400130

Site: 3 Code Area: 14530 Size: 141.00 Acres Use Code: 005 Zone: REST SAV Use: 011 Exception: 0
 Class: 2BISS Value Source: Farm Use - EFU Description: TWO BENCH IRR SOUTH SPECIAL RMV: 445910 Exception: Y N
 Adjustment(s): GSOIL, WASTE, IRR Fire Patrol: Description:
 Comments: Liability year - 1980 / 00-01; UPDATED MARKET VALUE, 81400130

Site: 4 Code Area: 14530 Size: 91.00 Acres Use Code: 005 Zone: REST SAV Use: 011 Exception: 0
 Class: 4BISS Value Source: Farm Use - EFU Description: FOUR BENCH IRR SPECIAL SOUTH RMV: 262760 Exception: Y N
 Adjustment(s): GSOIL, WASTE, IRR Fire Patrol: Description:
 Comments: Liability year - 1980 / 00-01; UPDATED MARKET VALUE, 81400130

Site: 5 Code Area: 14530 Size: 2.76 Acres Use Code: 005 Zone: REST SAV Use: 011 Exception: 0
 Class: WST Value Source: Farm Use - EFU Description: Rural WASTELAND RMV: 230 Exception: Y N
 Adjustment(s): GSOIL, WASTE, IRR Fire Patrol: Description:
 Comments: Liability year - 1980 / 00-01; UPDATED MARKET VALUE, 81400130

Improvements - Residence / Manufactured Structures

Bldg: 1 Code Area: 14530 Stat Class: 132 Year Blt: 1925 Eff Year Blt: 1940 Sq.Ft: 1488 % Complete: 100
 Desc: Multi Story above grade Dimensions: RMV: 116690
 Func Obsc: 100 Econ %: 100 Other %: 100 Exception: 0 Adjust: Adjust RMV: 0

Floors

Type	Class	Display Group	Floor Size	Beds	Baths	Yr Blt	Eff Yr Blt	Inventory	Exception
First Floor	3	Finished	1008	2	FB-1	1925	1940	HVAC, ROOF, KIT-, BATH - 1	Y N
Attic	3	Finished	480	0	0	1925	1940		Y N
Carport Detached	3	Unfinished	242	0	0	1925	1940	ROOF	Y N

Accessories

Description	Class	Size SqFt	Eff Yr Blt	RMV	Quantity	Exception
YARD IMPROVEMENTS FAIR	3	1	1940	5859	1	Y N

Bldg: 7 Code Area: 14530 Stat Class: 108 Year Blt: 2009 Eff Year Blt: 2009 Sq.Ft: 0 % Complete: 100
 Desc: Residential Other Improvements Dimensions: RMV: 86030
 Func Obsc: 100 Econ %: 100 Other %: 100 Exception: 0 Adjust: Adjust RMV: 0

Floors

Type	Class	Display Group	Floor Size	Beds	Baths	Yr Blt	Eff Yr Blt	Inventory
No floor data available								

Accessories

Description	Class	Size SqFt	Eff Yr Blt	RMV	Quantity	Exception
ASPHALT DRIVEWAY	1	37000	2009	86025	1	Y N

Improvements - Accessory Buildings

Bldg: 2 Code Area: 14530 Stat Class: 353 Year Blt: 1985 Eff Year Blt: 1985 Sq.Ft: 2560 % Complete: 100

Desc: Machine Shed (MS)

Dimensions: 80x32

RMV: 8630

Func Obsc: 100

Econ %: 100

Other %: 100

Exception: 0

Adjust:

Adjust RMV: 0

Floors

Type	Class	Display Group	Floor Size	Beds	Baths	Yr Blt	Eff Yr Blt	Inventory	Exception: Y N
Machine Shed	5	Finished	2560	0	0	1985	1985	FAIR	

Accessories

Description	Class	Size SqFt	Eff Yr Blt	RMV	Quantity
No accessory data available					

Bldg: 3 Code Area: 14530 Stat Class: 351 Year Blt: 1985 Eff Year Blt: 1985 Sq.Ft: 1440 % Complete: 100
 Desc: General Purpose Building (GB) Dimensions: 48x30 RMV: 7450
 Func Obsc: 100 Econ %: 100 Other %: 100 Exception: 0 Adjust: Adjust RMV: 0

Floors

Type	Class	Display Group	Floor Size	Beds	Baths	Yr Blt	Eff Yr Blt	Inventory	Exception: Y N
General Purpose Bldg	5	Finished	1440	0	0	1985	1985	FAIR	

Accessories

Description	Class	Size SqFt	Eff Yr Blt	RMV	Quantity
No accessory data available					

Bldg: 4 Code Area: 14530 Stat Class: 351 Year Blt: 1985 Eff Year Blt: 1985 Sq.Ft: 4464 % Complete: 100
 Desc: General Purpose Building (GB) Dimensions: 100x36 RMV: 32520
 Func Obsc: 100 Econ %: 100 Other %: 100 Exception: 0 Adjust: Adjust RMV: 0

Floors

Type	Class	Display Group	Floor Size	Beds	Baths	Yr Blt	Eff Yr Blt	Inventory	Exception: Y N
General Purpose Bldg	5	Finished	3600	0	0	1985	1985	FAIR	
Finished Office	5	Finished	864	0	0	1992	2000		

Accessories

Description	Class	Size SqFt	Eff Yr Blt	RMV	Quantity
No accessory data available					

Bldg: 5 Code Area: 14530 Stat Class: 342 Year Blt: 1998 Eff Year Blt: 1998 Sq.Ft: 33860 % Complete: 100
 Desc: Metal Component Building (MC) Dimensions: RMV: 479280
 Func Obsc: 100 Econ %: 100 Other %: 100 Exception: 0 Adjust: Adjust RMV: 0

Floors

Type	Class	Display Group	Floor Size	Beds	Baths	Yr Blt	Eff Yr Blt	Inventory	Exception: Y N
Metal Componet Bldg	6	Finished	33860	0	0	1998	1998	FAIR	

Accessories

Description	Class	Size SqFt	Eff Yr Blt	RMV	Quantity
No accessory data available					

Bldg: 6 Code Area: 14530 Stat Class: 305 Year Blt: 2000 Eff Year Blt: 2000 Sq.Ft: 0 % Complete: 100
 Desc: Tank/Silo/Bin Dimensions: RMV: 72900
 Func Obsc: 100 Econ %: 100 Other %: 100 Exception: 0 Adjust: Adjust RMV: 0

Floors

Type	Class	Display Group	Floor Size	Beds	Baths	Yr Blt	Eff Yr Blt	Inventory	Exception: Y N
No floor data available									

Accessories

Description	Class	Size SqFt	Eff Yr Blt	RMV	Quantity
No accessory data available					

(2) LTL
 24x79
 Eff Yr 2013

79 24 79

APEX UPDATED

R36612
093W28 00900



148'

10'

65'

20'

145'

MC
33860

FLTKAG



CD

30'

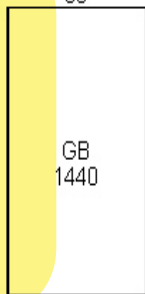

AD

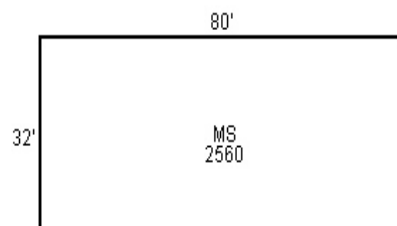

AD

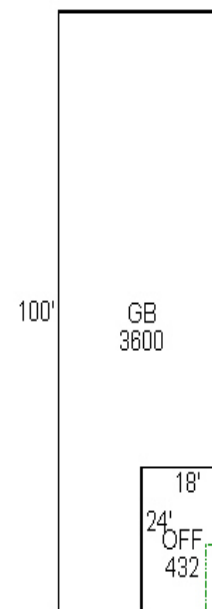

2nd story

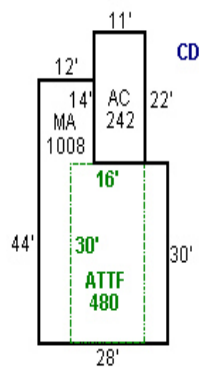

House located south of AD



R36612
093W28 00900



148'

MC
33860

10'

20'

145'

65'

FLTKAG



CD

30'

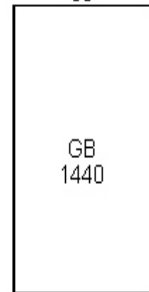

AD

80'

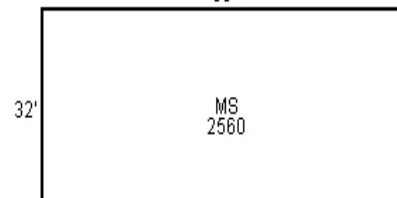

AD

100'

GB
3600

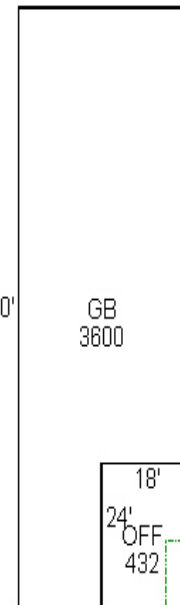

36'

2nd story

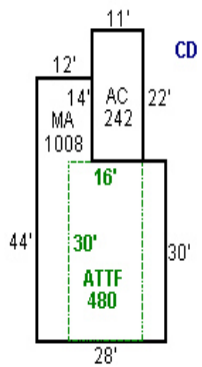

House located south of AD



Farm Buildings ↗

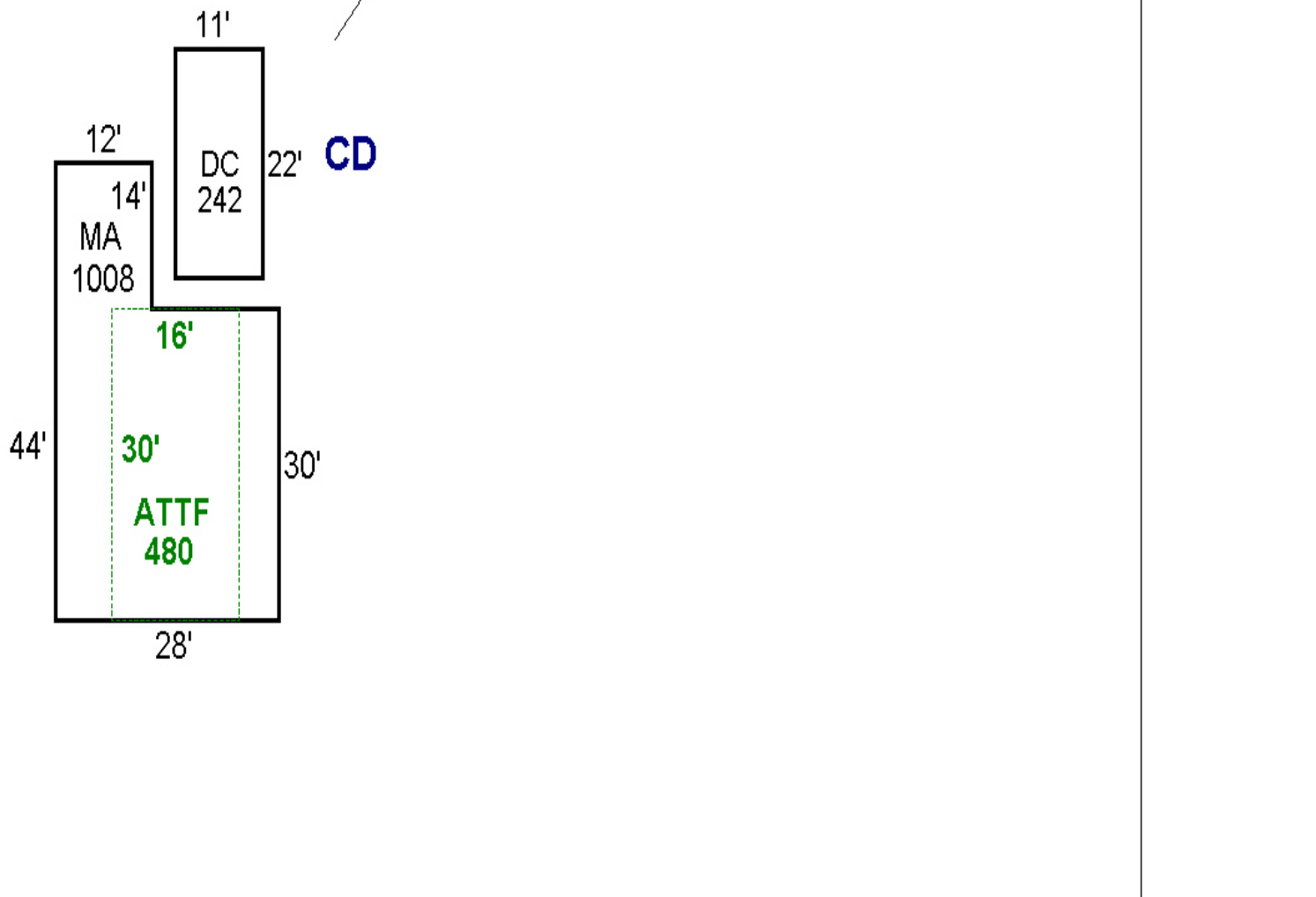

Farm Buildings ↗

