

SKETCH/AREA TABLE ADDENDUM

SUBJECT INFO

File No.: 333737 Parcel No.: 083W15CC05800
 Property Address: 527 GRANDOVER CT SE
 City: SALEM County: State: OR ZipCode: 97306
 Owner:
 Client: Client Address:
 Appraiser Name: Inspection Date:

SKETCH

333737
083W15CC05800

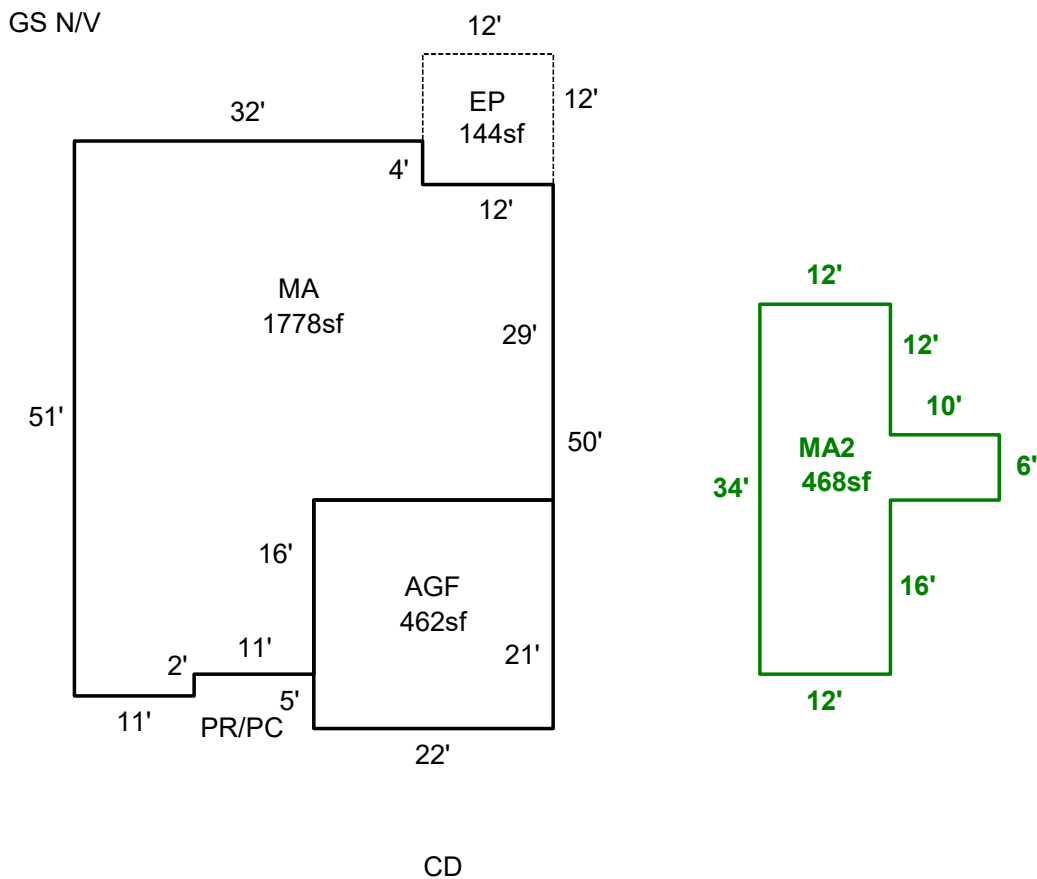

Sketch by ApexSketch

AREA CALCULATIONS SUMMARY

Code	Description	Factor	Net Size	Perimeter	Net Totals
GLA1	MA	1.0	1778.0	190.0	1778.0
GLA2	MA2	1.0	468.0	112.0	468.0
GAR	AGF	1.0	462.0	86.0	462.0
PR	EP	1.0	144.0	48.0	144.0

COMMENT TABLE 1

DRAWN BY SH 2-13-09
 UPDATED BY LK 6.4.24

COMMENT TABLE 2

4.23.24 CYCLE ZH

COMMENT TABLE 3

Net LIVABLE cnt 1 (rounded) 2,246