

SKETCH/AREA TABLE ADDENDUM

SUBJECT INFO

File No.: 596645 Parcel No.: 083W14AD03900
 Property Address: 5355 BERKSHIRE CT SE
 City: SALEM County: State: OR ZipCode: 97306
 Owner:
 Client: Client Address:
 Appraiser Name: Inspection Date:

SKETCH

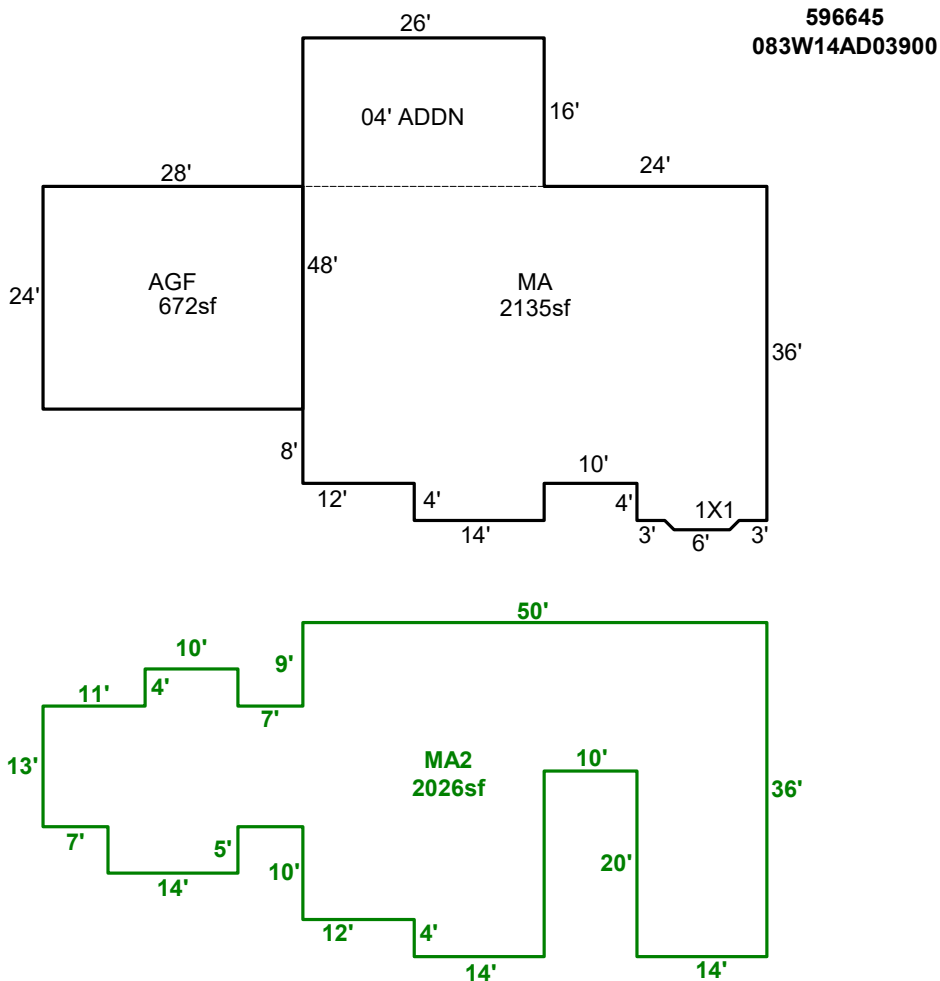

Sketch by ApexSketch

AREA CALCULATIONS SUMMARY

Code	Description	Factor	Net Size	Perimeter	Net Totals
GLA1	MA	1.0	2135.0	212.8	2135.0
GLA2	MA2	1.0	2026.0	286.0	2026.0
GARAGE	AGF	1.0	672.0	104.0	672.0

COMMENT TABLE 1

Apex by SH 12-8-09
 UPDATED BY LK 7.3.24

COMMENT TABLE 2

SV 06.04.24 GM

COMMENT TABLE 3

Net LIVABLE cnt 1 (rounded) 4,161