

SKETCH/AREA TABLE ADDENDUM

SUBJECT INFO

File No.: 607338 Parcel No.: 083W15CC14900
 Property Address: 5683 Jeremy Valley Dr SE
 City: Salem County: MARION State: OR ZipCode:
 Owner:
 Client: Client Address:
 Appraiser Name: Inspection Date:

SKETCH

607338
083W15CC14900

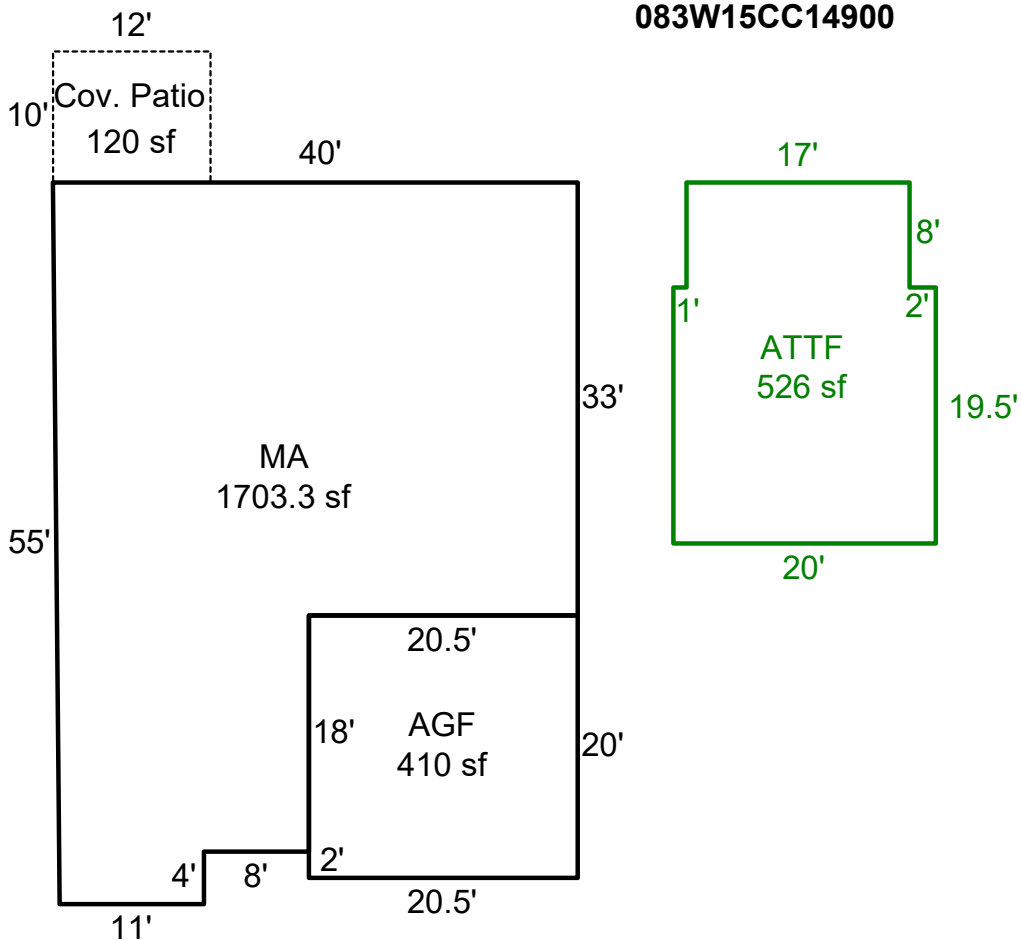

Sketch by ApexSketch

AREA CALCULATIONS SUMMARY

Code	Description	Factor	Net Size	Perimeter	Net Totals
GLA	MA	1.0	1703.3	189.5	1703.3
GLA2	ATTF	1.0	526.0	95.0	526.0
GAR	AGF	1.0	410.0	81.0	410.0
P/P	Cov. Patio	1.0	120.0	44.0	120.0

COMMENT TABLE 1

Drawn by AElwood 7/1/24

COMMENT TABLE 2

COMMENT TABLE 3

Net LIVABLE cnt 2 (rounded) 2,229