

Acct ID: 536598 MTL: 093W30A000700 Date: 6/20/24 Appr: MDL Prop Class: 401 RMV Prop Class: 401  
 Situs: 13324 MARLATT RD S JEFFERSON OR 97352 MaSaNh: 07 06 000 Unit: 32643 Year: 2024

Last Date Appraised: 01/06/2022 Appraiser: MATT LORD Retag: Y (N) Tag info:  
 Owner: LINDQUIST, ELWOOD J & LINDQUIST, PEGGY A Roll Type: R  
Cycle Tag Sales Verification Other: \_\_\_\_\_ Inspection level: 1 (2) 3 4 LCB TTO INSP AV: 317860  
 RMV Land: 212140 RMV Imp: 325340 RMV Total: 537480 MAV: 317860 MSAV: 0 SAV: 0  
 Comment: 22-23: L2 01.06.22 ML

**Notations**

No notation data available.

24-25 cycle

**OSDs**

Count	Code	Description	RMV	Code Area	Exception
1	MKTA	OSD - AVERAGE	45000	14530	0

**Land**

Site: 1 Code Area: 14530 Size: 0.93 Acres Use Code: 004 Zone: NREST SAV Use: Exception: 0  
 Class: Value Source: Rural at MKT Description: RMV: 167140 Exception: Y N  
 Adjustment(s): Fire Patrol: Description:  
 Comments: 03-04: REAPPRAISAL 04-05: RECALC PROJECT, LAND SCHEDULE CHANGES.

**Improvements - Residence / Manufactured Structures**

Bldg: 1 Code Area: 14530 Stat Class: 141 Year Blt: 1977 Eff Year Blt: 1987 Sq.Ft: 1722 % Complete: 100  
 Desc: One Story Only Dimensions: RMV: 267030  
 Func Obsc: 100 Econ %: 100 Other %: 100 Exception: 0 Adjust: Adjust RMV: 0

**Floors**

Type	Class	Display Group	Floor Size	Beds	Baths	Yr Blt	Eff Yr Blt	Inventory	Exception
First Floor	4	Finished	1722	3	FB-2	1977	1987	KIT, ROOF, HVAC, FP - 1, BATH - 2	Y N
Garage Attached	4	Finished	650	0	0	1977	1987	ROOF	Y N

**Accessories**

Description	Class	Size SqFt	Eff Yr Blt	RMV	Quantity	Exception
DECK	4	168	2021	3659	0	Y N
DECK	4	380	2021	8276	0	Y N
ROOF EXTENSION OR PATH COVER	4	380	2021	10910	0	Y N

Bldg: 4 Code Area: 14530 Stat Class: 107 Year Blt: Eff Year Blt: 1987 Sq.Ft: 0 % Complete: 100  
 Desc: Yard Improvements Dimensions: RMV: 22880  
 Func Obsc: 100 Econ %: 100 Other %: 100 Exception: 0 Adjust: Adjust RMV: 0

**Floors**

Type	Class	Display Group	Floor Size	Beds	Baths	Yr Blt	Eff Yr Blt	Inventory	Exception
No floor data available									

**Accessories**

Description	Class	Size SqFt	Eff Yr Blt	RMV	Quantity	Exception
YARD IMPROVEMENTS AVERAGE	4	1	1987	22878	1	Y N

**Improvements - Accessory Buildings**

Bldg: 2 Code Area: 14530 Stat Class: 351 Year Blt: 2008 Eff Year Blt: 2008 Sq.Ft: 1728 % Complete: 100  
 Desc: General Purpose Building (GB) Dimensions: 48x36 RMV: 33340  
 Func Obsc: 100 Econ %: 100 Other %: 100 Exception: 0 Adjust: Adjust RMV: 0

**Floors**

Type	Class	Display Group	Floor Size	Beds	Baths	Yr Blt	Eff Yr Blt	Inventory	Exception
General Purpose Bldg	5	Finished	1728	0	0	2008	2008	FAIR	Y N
GP Building Attic	5	Unfinished	256	0	0	2008	2008		Y N

**Accessories**

Description	Class	Size SqFt	Eff Yr Blt	RMV	Quantity	Exception
No accessory data available						

Bldg: 3 Code Area: 14530 Stat Class: 341 Year Blt: 2002 Eff Year Blt: 2008 Sq.Ft: 120 % Complete: 100  
 Desc: Multi Purpose Shed (MP) Dimensions: 10x12 RMV: 2090

Func Obsc: 100

Econ %: 100

Other %: 100

Exception: 0

Adjust:

Adjust RMV: 0

**Floors**

Type	Class	Display Group	Floor Size	Beds	Baths	Yr Blt	Eff Yr Blt	Inventory	Exception: Y <u>N</u>
Multi-Purpose Bldg	5	Finished	120	0	0	2002	2008		

**Accessories**

Description	Class	Size SqFt	Eff Yr Blt	RMV	Quantity
No accessory data available					

LTL (Part of MP)  
 2020 YR  
 10x12 - NO SQFT

# SKETCH/AREA TABLE ADDENDUM

## SUBJECT INFO

File No.: R36598 Parcel No.: 093W30A 00700  
 Property Address: 13324 MARLATT RD S  
 City: JEFFERSON County: State: OR ZipCode: 97352  
 Owner:  
 Client: Client Address:  
 Appraiser Name: Inspection Date:

## SKETCH

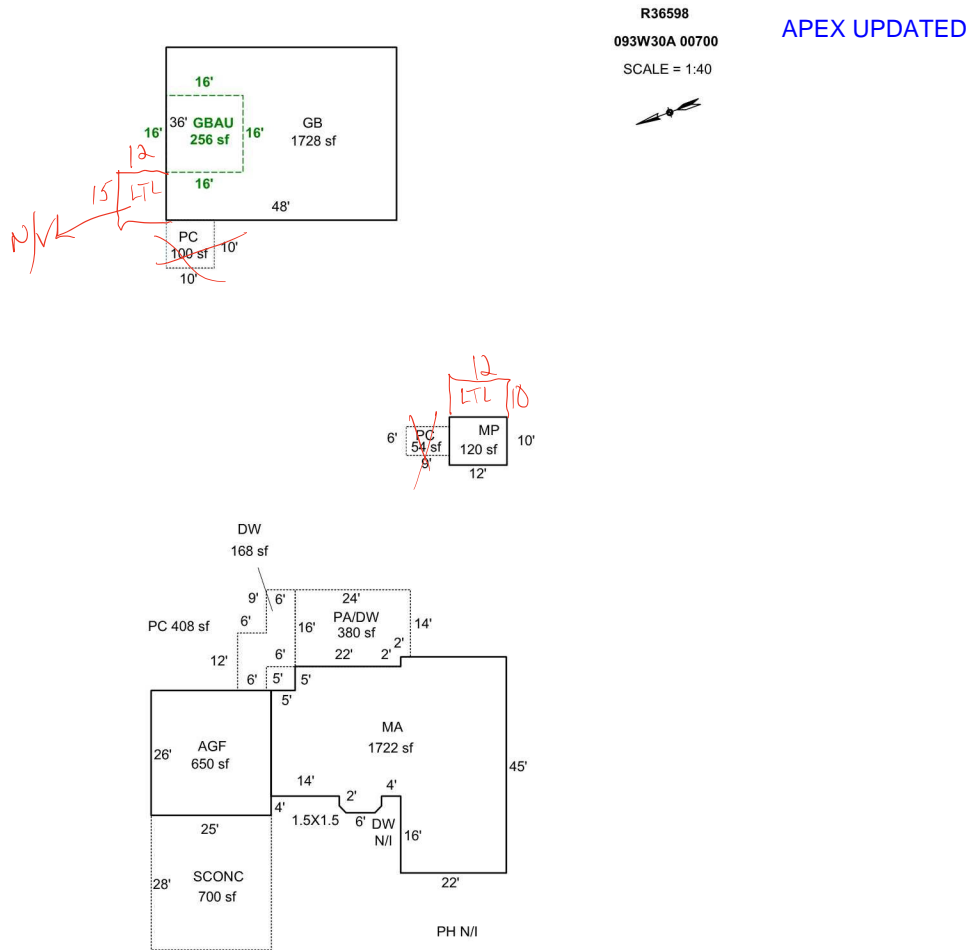

Sketch by Apex Sketch

AREA CALCULATIONS SUMMARY						COMMENT TABLE 1	
Code	Description	Factor	Net Size	Perimeter	Net Totals		
GBA1	MP	1.0	120.0	44.0		DRAWN BY NC 11/20/2008 UPDATED BY JRONDEMA 7/23/18 UPDATED BY CJURAN 09/15/2021 555-21-008121	
	GB	1.0	1728.0	168.0	1848.0		
GBA2	GBAU	1.0	256.0	64.0	256.0		
GLA1	MA	1.0	1722.1	193.2	1722.1		
GAR	AGF	1.0	650.0	102.0	650.0		
P/P	PC	1.0	100.0	40.0			
	PA/DW	1.0	380.0	80.0			
	DW	1.0	168.0	66.0			
	SCONC	1.0	700.0	106.0			
	PC	1.0	54.0	30.0	1402.0		
	Net LIVABLE	cnt	1 (rounded)		1,722	<b>COMMENT TABLE 2</b>	<b>COMMENT TABLE 3</b>
	Net BUILDING	cnt	3 (rounded)		2,104	<i>MSL 6/25/24</i>	<i>L2 Cycle</i>



R36598  
GB,GBAU

7/20/18



R36598  
MA BACK

7/20/18



R36598  
MA, AGF

7/20/18



R36598

MP

7/20/18



R36598

PH N/I

7/20/18

