

Acct ID: 536666 MTL: 093W35CD01600 Date: 7/9/24 Appr: MDL Prop Class: 401 RMV Prop Class: 401
 Situs: 15002 LAUREL LN SE JEFFERSON OR 97352 MaSaNh: 07 06 000 Unit: 51891 Year: 2024

Last Date Appraised: 08/15/2018 Appraiser: MATT LORD Retag: Y N Tag info:
 Owner: MCGEHEE, CHARLES L & MCGEHEE, KAREN M Roll Type: R
Cycle Tag Sales Verification Other: _____ Inspection level: 1 2 3 4 LCB TTO INSP AV: 326410
 RMV Land: 216920 RMV Imp: 348720 RMV Total: 565640 MAV: 326410 MSAV: 0 SAV: 0
 Comment:

Notations

No notation data available.

24-25 cycle

OSDs

Count	Code	Description	RMV	Code Area	Exception
1	MKTN	OSD - NO LANDSCAPE <i>FAIR</i>	30000	14530	0

Land

Site: 1 Code Area: 14530 Size: 1.50 Acres Use Code: 004 Zone: NREST SAV Use: Exception: 0
 Class: Value Source: Rural at MKT Description: RMV: 186920 Exception: Y N
 Adjustment(s): Fire Patrol: Description:
 Comments: 81400130 ,gis#00-94 sepe from r36666 to r327773 and r327774 03-04: REAPPRAISAL 03-04: L & L SUBDIVISION MERGING INTO SURROUNDING AREA 03-04: REAPPRAISAL /04-05: LAND ADJUSTMENT FOR RECALCULATION DONE BY #29 ON 5-4-04

Improvements - Residence / Manufactured Structures

Bldg: 1 Code Area: 14530 Stat Class: 142 Year Blt: 2003 Eff Year Blt: 2003 Sq.Ft: 2861 % Complete: 100
 Desc: Multi Story above grade Dimensions: RMV: 327720
 Func Obsc: 100 Econ %: 100 Other %: 100 Exception: 0 Adjust: Adjust RMV: 0

Floors

Type	Class	Display Group	Floor Size	Beds	Baths	Yr Blt	Eff Yr Blt	Inventory	Exception
First Floor	4	Finished	1088	0	FB-1/ HB-1	2003	2003	KIT+, ROOF, HVAC+, BTH - 1	Y N
Second Floor	4	Finished	1080	3	FB-2	2003	2003	HVAC+, BATH - 2	Y N
Attic	4	Finished	693	2	0	2003	2003	HVAC+	Y N

Accessories

Description	Class	Size SqFt	Eff Yr Blt	RMV	Quantity
No accessory data available					

Bldg: 3 Code Area: 14530 Stat Class: 107 Year Blt: Eff Year Blt: Sq.Ft: 0 % Complete: 100
 Desc: Yard Improvements Dimensions: RMV: 21000
 Func Obsc: 100 Econ %: 100 Other %: 100 Exception: 0 Adjust: Adjust RMV: 0

Floors

Type	Class	Display Group	Floor Size	Beds	Baths	Yr Blt	Eff Yr Blt	Inventory	Exception
No floor data available									

Accessories

Description	Class	Size SqFt	Eff Yr Blt	RMV	Quantity
YARD IMPROVEMENTS AVERAGE	5	0	0	21000	1
Exception: Y N					

Improvements - Accessory Buildings

No improvement data available for all other stat class types.

ADD to MA

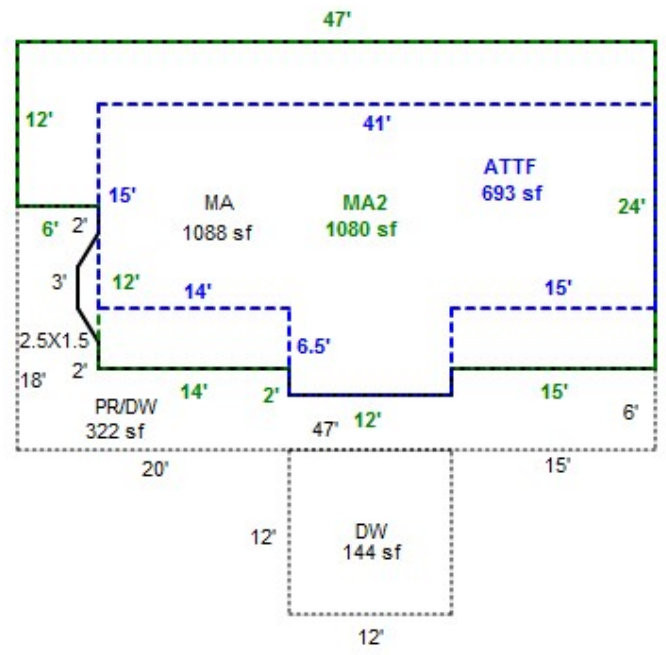
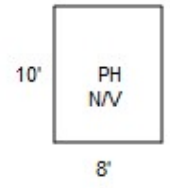

R36666
093W35CD01600

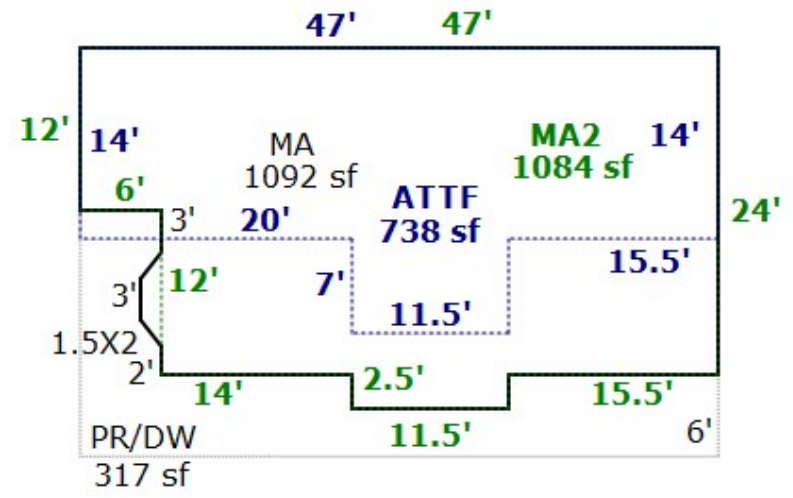



R36666 MA back
8/15/2018



R36666 MA
8/15/2018



R36666 PH NV
8/15/2018



7/9/24