

Acct ID: 536674 MTL: 093W350001200 Date: 8/2/24 Appr: MN Prop Class: 451 RMV Prop Class: 451
 Situs: 14861 JEFFERSON HWY 99E SE JEFFERSON OR 97352 MaSaNh: 07 06 000 Unit: 53175 Year: 2024

Last Date Appraised: 07/27/2018 Appraiser: MATT LORD Retag: Y (N) Tag info:
 Owner: LUKE, STEVE A Roll Type: R
 Cycle Tag Sales Verification Other: _____ Inspection level: 1 2 (3) 4 LCB TTO INSP AV: 316420
 RMV Land: 255460 RMV Imp: 413050 RMV Total: 668510 MAV: 316420 MSAV: 0 SAV: 0
 Comment:

Notations 24-25 cycle
 No notation data available.

OSDs

Count	Code	Description	RMV	Code Area	Exception
1	MKTA	OSD - AVERAGE	45000	14530	0

Land
 Site: 1 Code Area: 14530 Size: 2.49 Acres Use Code: 005 Zone: REST SAV Use: Exception: 0
 Class: Value Source: Rural Restrictive Description: RMV: 210460 Exception: Y N
 Adjustment(s): Fire Patrol: Description:
 Comments: 03-04: REAPPRAISAL

Improvements - Residence / Manufactured Structures
 Bldg: 1 Code Area: 14530 Stat Class: 454 Year Blt: 1977 Eff Year Blt: 2008 Sq.Ft: 1546 % Complete: 100
 Desc: MANUF STRUCT, CLASS 5, 14' WIDE SINGLE Dimensions: RMV: 113760
 Func Obsc: 100 Econ %: 100 Other %: 100 Exception: 0 Adjust: Adjust RMV: 0

Floors

Type	Class	Display Group	Floor Size	Beds	Baths	Yr Blt	Eff Yr Blt	Inventory	Exception
First Floor	5	Finished	1546	3	FB-2	1977	2008	KIT, SKRT+, ROOF+, HVAC+, BATH - 2	Y N

Accessories
 Description Class Size SqFt Eff Yr Blt RMV Quantity
 No accessory data available

Bldg: 1 Code Area: 14530 Stat Class: 132 Year Blt: 1910 Eff Year Blt: 1978 Sq.Ft: 2652 % Complete: 100
 Desc: Multi Story above grade Dimensions: RMV: 222960
 Func Obsc: 100 Econ %: 100 Other %: 100 Exception: 0 Adjust: Adjust RMV: 0

Floors

Type	Class	Display Group	Floor Size	Beds	Baths	Yr Blt	Eff Yr Blt	Inventory	Exception
First Floor	3	Finished	1298	1	FB-1	1910	1978	KIT-, FP - 1, HVAC, ROOF, BATH - 1	Y N
Second Floor	3	Finished	1354	8	0	1910	1978	HVAC	Y N
Attic	3	Unfinished	120	0	0	1910	1978		Y N

Accessories

Description	Class	Size SqFt	Eff Yr Blt	RMV	Quantity	Exception
ASPHALT DRIVEWAY	3	1380	1978	3229	1	Y N
CONCRETE DRIVEWAY	3	192	1998	549	1	Y N
CONCRETE DRIVEWAY	3	256	1983	666	1	Y N
DECK	3	56	2020	1220	1	Y N
DECK	3	90	2020	1960	1	Y N
PATIO	3	256	1998	1239	1	Y N

Bldg: 2 Code Area: 14530 Stat Class: 148 Year Blt: 1992 Eff Year Blt: 1998 Sq.Ft: 0 % Complete: 100
 Desc: Res other improvements Dimensions: RMV: 46180
 Func Obsc: 100 Econ %: 100 Other %: 100 Exception: 0 Adjust: Adjust RMV: 0

Floors

Type	Class	Display Group	Floor Size	Beds	Baths	Yr Blt	Eff Yr Blt	Inventory	Exception
Garage Detached	4	Unfinished	576	0	0	1992	1998	ROOF	Y N

Accessories
 Description Class Size SqFt Eff Yr Blt RMV Quantity
 No accessory data available

Bldg: 9 Code Area: 14530 Stat Class: 107 Year Blt: Eff Year Blt: 2008 Sq.Ft: 0 % Complete: 100

~~Desc: Yard Improvements~~ *RES other improvements For MFH* Dimensions: RMV: 7250
 Func Obsc: 100 Econ %: 100 Other %: 100 Exception: 0 Adjust: Adjust RMV: 0

Floors

Type	Class	Display Group	Floor Size	Beds	Baths	Yr Blt	Eff Yr Blt	Inventory
------	-------	---------------	------------	------	-------	--------	------------	-----------

No floor data available

Accessories

Description	Class	Size SqFt	Eff Yr Blt	RMV	Quantity	Exception: Y N
CONCRETE DRIVEWAY	1	360	2008	1088	1	Exception: Y N
PATIO	1	255	2008	1304	0	Exception: Y N
ROOF EXTENSION OR PATIO COVER	1	180	2008	4855	1	Exception: Y N

Improvements - Accessory Buildings

Bldg: 3 Code Area: 14530 Stat Class: 341 Year Blt: Eff Year Blt: 2002 Sq.Ft: 128 % Complete: 100
 Desc: Multi Purpose Shed (MP) Dimensions: 16x8 RMV: 1570
 Func Obsc: 100 Econ %: 100 Other %: 100 Exception: 0 Adjust: Adjust RMV: 0

Floors

Type	Class	Display Group	Floor Size	Beds	Baths	Yr Blt	Eff Yr Blt	Inventory
Multi-Purpose Bldg	4	Finished	128	0	0	2002	2002	Exception: Y N

Accessories

Description	Class	Size SqFt	Eff Yr Blt	RMV	Quantity
-------------	-------	-----------	------------	-----	----------

No accessory data available

Bldg: 4 Code Area: 14530 Stat Class: 353 Year Blt: Eff Year Blt: 1977 Sq.Ft: 480 % Complete: 100
 Desc: Machine Shed (MS) Dimensions: 24x20 RMV: 1810
 Func Obsc: 100 Econ %: 100 Other %: 100 Exception: 0 Adjust: Adjust RMV: 0

Floors

Type	Class	Display Group	Floor Size	Beds	Baths	Yr Blt	Eff Yr Blt	Inventory
Machine Shed	5	Finished	480	0	0	1977	1977	FAIR Exception: Y N

Accessories

Description	Class	Size SqFt	Eff Yr Blt	RMV	Quantity
-------------	-------	-----------	------------	-----	----------

No accessory data available

Bldg: 5 Code Area: 14530 Stat Class: 351 Year Blt: Eff Year Blt: 1975 Sq.Ft: 2304 % Complete: 100
 Desc: General Purpose Building (GB) Dimensions: 72x32 RMV: 9410
 Func Obsc: 100 Econ %: 100 Other %: 100 Exception: 0 Adjust: Adjust RMV: 0

Floors

Type	Class	Display Group	Floor Size	Beds	Baths	Yr Blt	Eff Yr Blt	Inventory
General Purpose Bldg	5	Finished	2304	0	0	1975	1983	FAIR Exception: Y N

Accessories

Description	Class	Size SqFt	Eff Yr Blt	RMV	Quantity
-------------	-------	-----------	------------	-----	----------

No accessory data available

Bldg: 6 Code Area: 14530 Stat Class: 351 Year Blt: 2002 Eff Year Blt: 2002 Sq.Ft: 512 % Complete: 100
 Desc: General Purpose Building (GB) Dimensions: 16x32 RMV: 6840
 Func Obsc: 100 Econ %: 100 Other %: 100 Exception: 0 Adjust: Adjust RMV: 0

Floors

Type	Class	Display Group	Floor Size	Beds	Baths	Yr Blt	Eff Yr Blt	Inventory
General Purpose Bldg	5	Finished	512	0	0	2002	2002	FAIR Exception: Y N

Accessories

Description	Class	Size SqFt	Eff Yr Blt	RMV	Quantity
-------------	-------	-----------	------------	-----	----------

No accessory data available

Bldg: 7 Code Area: 14530 Stat Class: 321 Year Blt: Eff Year Blt: 2002 Sq.Ft: 231 % Complete: 100
 Desc: Hay Cover (HC) Dimensions: 11x21 RMV: 1060
 Func Obsc: 100 Econ %: 100 Other %: 100 Exception: 0 Adjust: Adjust RMV: 0

Floors

Type	Class	Display Group	Floor Size	Beds	Baths	Yr Blt	Eff Yr Blt	Inventory
Hay Cover	4	Finished	231	0	0	2002	2002	FAIR Exception: Y N

Accessories

Description	Class	Size SqFt	Eff Yr Blt	RMV	Quantity
-------------	-------	-----------	------------	-----	----------

No accessory data available

Bldg: 8 Code Area: 14530 Stat Class: 355 Year Blt: Eff Year Blt: 1977 Sq.Ft: 336 % Complete: 100
 Desc: Lean-to Heavy (LTH) Dimensions: 14x24 RMV: 450
 Func Obsc: 100 Econ %: 100 Other %: 100 Exception: 0 Adjust: Adjust RMV: 0

Floors

Type	Class	Display Group	Floor Size	Beds	Baths	Yr Blt	Eff Yr Blt	Inventory
Lean-to Heavy Duty	4	Finished	336	0	0	1977	1977	Exception: Y N

Accessories

Description	Class	Size SqFt	Eff Yr Blt	RMV	Quantity
-------------	-------	-----------	------------	-----	----------

No accessory data available

Bldg: 10 Code Area: 14530 Stat Class: 354 Year Blt: 2016 Eff Year Blt: 2016 Sq.Ft: 505 % Complete: 100
 Desc: Lean-to Light (LTL) Dimensions: RMV: 1760
 Func Obsc: 100 Econ %: 100 Other %: 100 Exception: 0 Adjust: Adjust RMV: 0

Floors

Type	Class	Display Group	Floor Size	Beds	Baths	Yr Blt	Eff Yr Blt	Inventory
Lean-to Light Duty	4	Finished	505	0	0	2016	2016	Exception: Y N

Accessories

Description	Class	Size SqFt	Eff Yr Blt	RMV	Quantity
-------------	-------	-----------	------------	-----	----------

No accessory data available

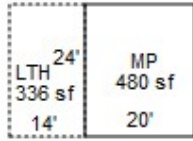

R36674
093W35 01200
SCALE=1:50

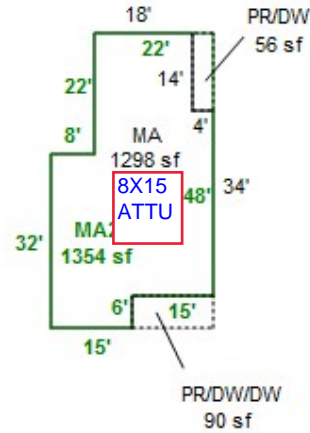
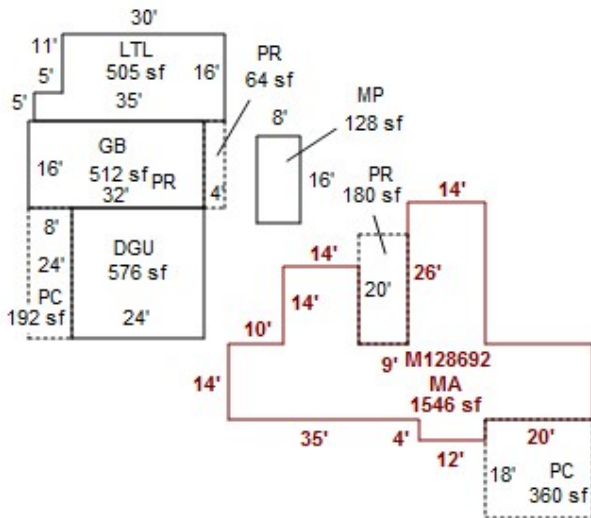
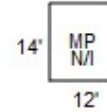
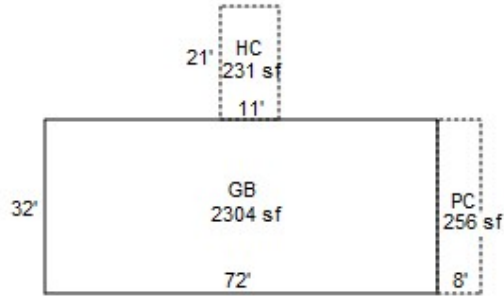

Mod L3
8/2/24 a/k/c



R36674
GB 16X32, DGU

7/27/18



R36674

MP 8X16, LTL, GB BACK

7/27/18



R36674
GB 32X72

7/27/18



R36674

HC

7/27/18



R36674

MA, MA2 BACK

7/27/18



R36674

MA,MA2

7/27/18



R36674

MP N/I 6X10

7/27/18



R36674

MP 12X14 N/I

7/27/18



R36674

MP 20X24, LTH

7/27/18













