

Summary

Lead Appr: _____ Clerk: Chris 10/20/23 Lead Clerk: _____ Appr: MDL

Acct ID: 530795 MTL: 082W28B000500 Date: 6/16/23 Appr: MDL Prop Class: 641 RMV Prop Class: 401
Situs: 7079 COMBEST LN SE TURNER OR 97392 MaSaNh: 07 06 000 Unit: 75569 Year: 2023
Last Date Appraised: 06/21/2019 Appraiser: MATT LORD Retag: Y (N) Tag info:
Owner: VERBICS, BELLE ANN Roll Type: R
Cycle Tag Sales Verification Other: _____ Inspection level: 1 2 3 4 LCB TTO INSP AV: 242729
RMV Land: 203370 RMV Imp: 484410 RMV Total: 687780 MAV: 241650 MSAV: 1079 SAV: 1676
Comment:

Notations

MATURE Trees and Young Newer Trees

RP/MS	Code	Description
RP	DFL	DESIGNATED FORESTLAND

OSDs

Count	Code	Description	RMV	Code Area	Exception
1	MKTA	OSD - AVERAGE	45000	05590	0

Land

Site: 1 Code Area: 05590 Size: 0.54 Acres Use Code: 005 Zone: REST SAV Use: Exception: 0
Class: Value Source: Market Homesite Description: RMV: 33670 Exception: Y N
Adjustment(s): Fire Patrol: Description:

Comments: 16-17: PER #36 ROLL 2.0 ACRES FROM FARM (0.54 OF WHICH IS SA HOMESITE) TO DFL. DISQ HOMESITE AND OSD AS < 10 ACRES// 99-2000: DISQ FARM USE / 2000-2001; MARKET LAND VALUES UPDATED . FARM USE APPROVED / 02-03: REAPP

Site: 3 Code Area: 05590 Size: 1.54 Acres Use Code: 005 Zone: REST SAV Use: 011 Exception: 0
Class: DFLC Value Source: Designated Forest Land Description: DESIG FOREST FC0 RMV: 96020 Exception: Y N
Adjustment(s): OK Fire Patrol: Description:

Comments: Liability year - 2000 / 00-01: 00500190, FARM USE APPROVED /01-02; CHANGED SOIL CLASS FROM 3 HILL DRY TO 4 HILL DRY

Site: 4 Code Area: 05590 Size: 0.46 Acres Use Code: 005 Zone: REST SAV Use: 011 Exception: 0
Class: DFLC Value Source: Designated Forest Land Description: DESIG FOREST FC0 RMV: 28680 Exception: Y N
Adjustment(s): OK Fire Patrol: Description:

Comments: Liability year - 2009

Improvements - Residence / Manufactured Structures

Bldg: 1 Code Area: 05590 Stat Class: 142 Year Blt: 1958 Eff Year Blt: 2001 Sq.Ft: 3803 % Complete: 100
Desc: Multi Story above grade Dimensions: RMV: 483100
Func Obsc: 100 Econ %: 100 Other %: 100 Exception: 0 Adjust: Adjust RMV: 0

Floors

Type	Class	Display Group	Floor Size	Beds	Baths	Yr Blt	Eff Yr Blt	Inventory	Exception
First Floor	4	Finished	2322	3	FB-2	1958	2001	BATH - 2, KIT-, ROOF, HVAC, FP	Y N
Attic	4	Finished	1481	0	0	1958	2001	HVAC	Y N
Garage Attached	4	Unfinished	936	0	0	1975	1975	ROOF	Y N

Accessories

Description	Class	Size SqFt	Eff Yr Blt	RMV	Quantity	Exception
DECK	4	84	2001	1663	1	Y N
DECK	4	220	2001	4356	1	Y N
PATIO	4	464	1958	1786	1	Y N
PATIO	4	1060	2001	5247	1	Y N
ROOF EXTENSION OR PATIO COVER	4	72	1958	1462	1	Y N
ROOF EXTENSION OR PATIO COVER	4	168	1958	3410	1	Y N
ROOF EXTENSION OR PATIO COVER	4	289	1958	5867	1	Y N
ROOF EXTENSION OR PATIO COVER	4	328	1958	6658	1	Y N

Improvements - Accessory Buildings

Bldg: 2 Code Area: 05590 Stat Class: 341 Year Blt: 1964 Eff Year Blt: 1964 Sq.Ft: 416 % Complete: 100
Desc: Multi Purpose Shed (MP) Dimensions: 26x16 RMV: 1310
Func Obsc: 100 Econ %: 100 Other %: 100 Exception: 0 Adjust: Adjust RMV: 0

Floors

Type	Class	Display Group	Floor Size	Beds	Baths	Yr Blt	Eff Yr Blt	Inventory	Exception
Multi-Purpose Bldg	4	Finished	416	0	0	1964	1964		Y N

Accessories

Description	Class	Size SqFt	Eff Yr Blt	RMV	Quantity
No accessory data available					

R30795
082W28B 00500
 SCALE=1:20

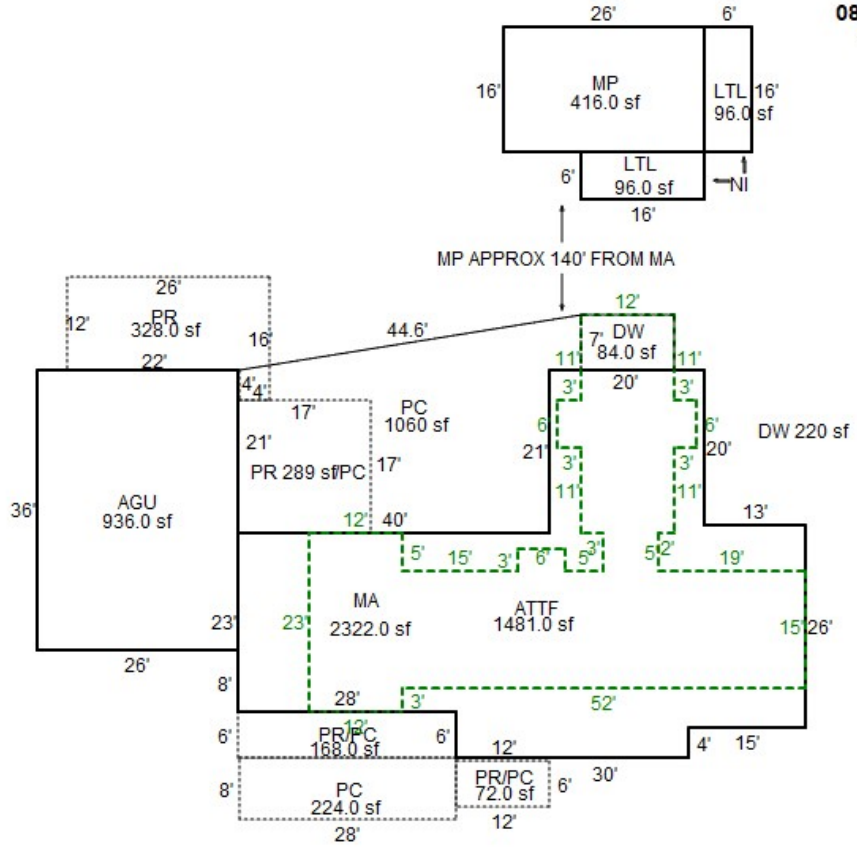
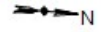

R30795
082W28B 00500
SCALE=1:20

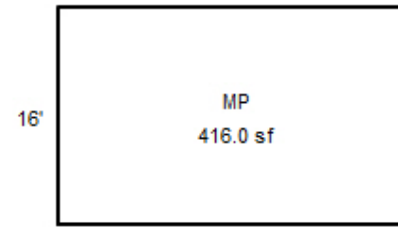
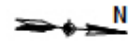

26'

MP APPROX 140' FROM MA

