

Acct ID: 533246 MTL: 083W300000800 Date: *2-1-24* Appr: *WW* Prop Class: 581 RMV Prop Class: 581
 Situs: 7934 SKYLINE RD S SALEM OR 97306 MaSaNh: 06 06 000 Unit: 54903 Year: 2024

Last Date Appraised: 06/12/2001 Appraiser: WENDY WILLIAMS Retag: *Y* *N* Tag info: 2024 - Tags/Permit (Addition)

Owner: BEVERLY M BRYLSKI TR Roll Type: R

Cycle: *Tag* Sales Verification Other: _____ Inspection level: *1* 2 3 4 LCB *TTO* *INSP* AV: 701663

RMV Land: 858920 RMV Imp: 786540 RMV Total: 1645460 MAV: 680950 MSAV: 20713 SAV: 34631

Comment: 22-23 MDL L4 06/02/22 UPDATED VIEW ADJ //

used unr chg 903 to BSM TF

23-003542 REMODEL
 ADDITION TO ADD 2
 BDRMS TO
 BASEMENT, 2 TO 5
 BDRM
 FINALED 12/7/23

Notations

RP/MS	Code	Description
RP	DFL	DESIGNATED FORESTLAND
RP	ZONED	FARM EFU ZONED

FARM USE: *livestock*
 FOREST:

OSDs

Count	Code	Description	RMV	Code Area	Exception
1	SAA	SA OSD - AVERAGE	45000	92000	0

Land

Site: 1 Code Area: 92000 Size: 1.00 Acres Use Code: 005 Zone: REST SAV Use: 011 Exception: 0
 Class: Value Source: Farm Homesite Description: RMV: 68910 Exception: Y N

Adjustment(s): VIEWE Fire Patrol: Description:

Comments: Liability year - 2009 / 16-17: CONVERT 15 ACRES DFL TO 4HILL DRY PER #73 / 2400000: 01-02; REAPPRAISAL 2400000: 01-02; REAPPRAISAL

Site: 2 Code Area: 92000 Size: 6.00 Acres Use Code: 005 Zone: REST SAV Use: 011 Exception: 0
 Class: 4HD Value Source: Farm Use - EFU *+3.44* Description: FOUR HILL DRY RMV: 83460 Exception: Y N

Adjustment(s): VIEWE Fire Patrol: Description:

Comments: Liability year - 1981 / 02400000: 01-02; CHANGED SOIL CLASS FROM 3 HILL DRY TO 4 HILL DRY /01-02; REAPPRAISAL

Site: 3 Code Area: 92000 Size: 7.94 Acres Use Code: 005 Zone: REST SAV Use: 011 Exception: 0
 Class: FTLC Value Source: Designated Forest Land Description: DFL Class C RMV: 110440 Exception: Y N

Adjustment(s): VIEWE *4.50* Fire Patrol: Description:

Comments: Liability year - 1981 / 2400000: 01-02; REAPPRAISAL

Site: 4 Code Area: 92000 Size: 39.62 Acres Use Code: 005 Zone: REST SAV Use: Exception: 0
 Class: Value Source: Rural Restrictive Description: RMV: 551110 Exception: Y N

Adjustment(s): VIEWE Fire Patrol: Description:

Comments:

Improvements - Residence / Manufactured Structures

Bldg: 1 Code Area: 92000 Stat Class: 154 Year Blt: 1985 Eff Year Blt: 1985 Sq.Ft: 4199 % Complete: 100

Desc: Multi Story above grade with basement 1990 Dimensions: RMV: 746990

Func Obsc: 100 Econ %: 100 Other %: 100 Exception: 0 *gomas* Adjust: Adjust RMV: 0

Floors

Type	Class	Display Group	Floor Size	Beds	Baths	Yr Blt	Eff Yr Blt	Inventory	Exception:
First Floor	5	Finished	2535	1	FB-2	1985	1985	ROOF, FP, HVAC+, KIT+, BATH - 2	Y N
Attic	5	Finished	1106	2	FB-2	1985	1985	HVAC+, BATH - 2	Y N
Attic	<i>CL 5 I/O</i>	Finished	558	0	0	1985	1985		Y N
Basement	5	Unfinished	2519	0	2	0	1985	1985	903 NOW FIN
Garage Attached	5	Finished	744	0	0	1985	1985	ROOF	Y N

Accessories

Description	Class	Size SqFt	Eff Yr Blt	RMV	Quantity
YARD IMPROVEMENTS AVERAGE	5	1	1985	30618	1

Bldg: 6 Code Area: 92000 Stat Class: 108 Year Blt: 2000 Eff Year Blt: 2000 Sq.Ft: 0 % Complete: 100

Desc: Residential Other Improvements Dimensions: RMV: 15350

Func Obsc: 100 Econ %: 100 Other %: 100 Exception: 0 Adjust: Adjust RMV: 0

Floors

Type	Class	Display Group	Floor Size	Beds	Baths	Yr Blt	Eff Yr Blt	Inventory
No floor data available								

Accessories

Description	Class	Size SqFt	Eff Yr Blt	RMV	Quantity	
ASPHALT DRIVEWAY	1	6900	2000	15353	1	Exception: Y N

Improvements - Accessory Buildings

Bldg: 2	Code Area: 92000	Stat Class: 351	Year Blt: 1985	Eff Year Blt: 1985	Sq.Ft: 1152	% Complete: 100
Desc: General Purpose Building (GB)			Dimensions: 48x24		RMV: 5210	
Func Obsc: 100	Econ %: 100	Other %: 100	Exception: 0	Adjust:	Adjust RMV: 0	

Floors

Type	Class	Display Group	Floor Size	Beds	Baths	Yr Blt	Eff Yr Blt	Inventory	
General Purpose Bldg	5	Finished	1152	0	0	1985	1985	fair	Exception: Y N

Accessories

Description	Class	Size SqFt	Eff Yr Blt	RMV	Quantity
No accessory data available					

Bldg: 3	Code Area: 92000	Stat Class: 351	Year Blt: 1997	Eff Year Blt: 1987	Sq.Ft: 1728	% Complete: 100
Desc: General Purpose Building (GB)			Dimensions: 48x36		RMV: 10080	
Func Obsc: 100	Econ %: 100	Other %: 100	Exception: 0	Adjust:	Adjust RMV: 0	

Floors

Type	Class	Display Group	Floor Size	Beds	Baths	Yr Blt	Eff Yr Blt	Inventory	
General Purpose Bldg	5	Finished	1728	0	0	1997	1987	FAIR	Exception: Y N

Accessories

Description	Class	Size SqFt	Eff Yr Blt	RMV	Quantity
No accessory data available					

Bldg: 4	Code Area: 92000	Stat Class: 301	Year Blt: 1997	Eff Year Blt: 1997	Sq.Ft: 0	% Complete: 100
Desc: Accessory Improvements & Misc.			Dimensions:		RMV: 8100	
Func Obsc: 100	Econ %: 100	Other %: 100	Exception: 0	Adjust:	Adjust RMV: 0	

Floors

Type	Class	Display Group	Floor Size	Beds	Baths	Yr Blt	Eff Yr Blt	Inventory	
No floor data available									

Accessories

Description	Class	Size SqFt	Eff Yr Blt	RMV	Quantity	
MISCELLANEOUS	0	0	1997	6000	1	Exception: Y N

Bldg: 5	Code Area: 92000	Stat Class: 301	Year Blt: 1997	Eff Year Blt: 1997	Sq.Ft: 280	% Complete: 100
Desc: Accessory Improvements & Misc.			Dimensions: 20x14		RMV: 810	
Func Obsc: 100	Econ %: 100	Other %: 100	Exception: 0	Adjust:	Adjust RMV: 0	

Floors

Type	Class	Display Group	Floor Size	Beds	Baths	Yr Blt	Eff Yr Blt	Inventory	
Pump House	0	Finished	280	0	0	1997	1997	fair PH	Exception: Y N

Accessories

Description	Class	Size SqFt	Eff Yr Blt	RMV	Quantity
No accessory data available					



1

PH





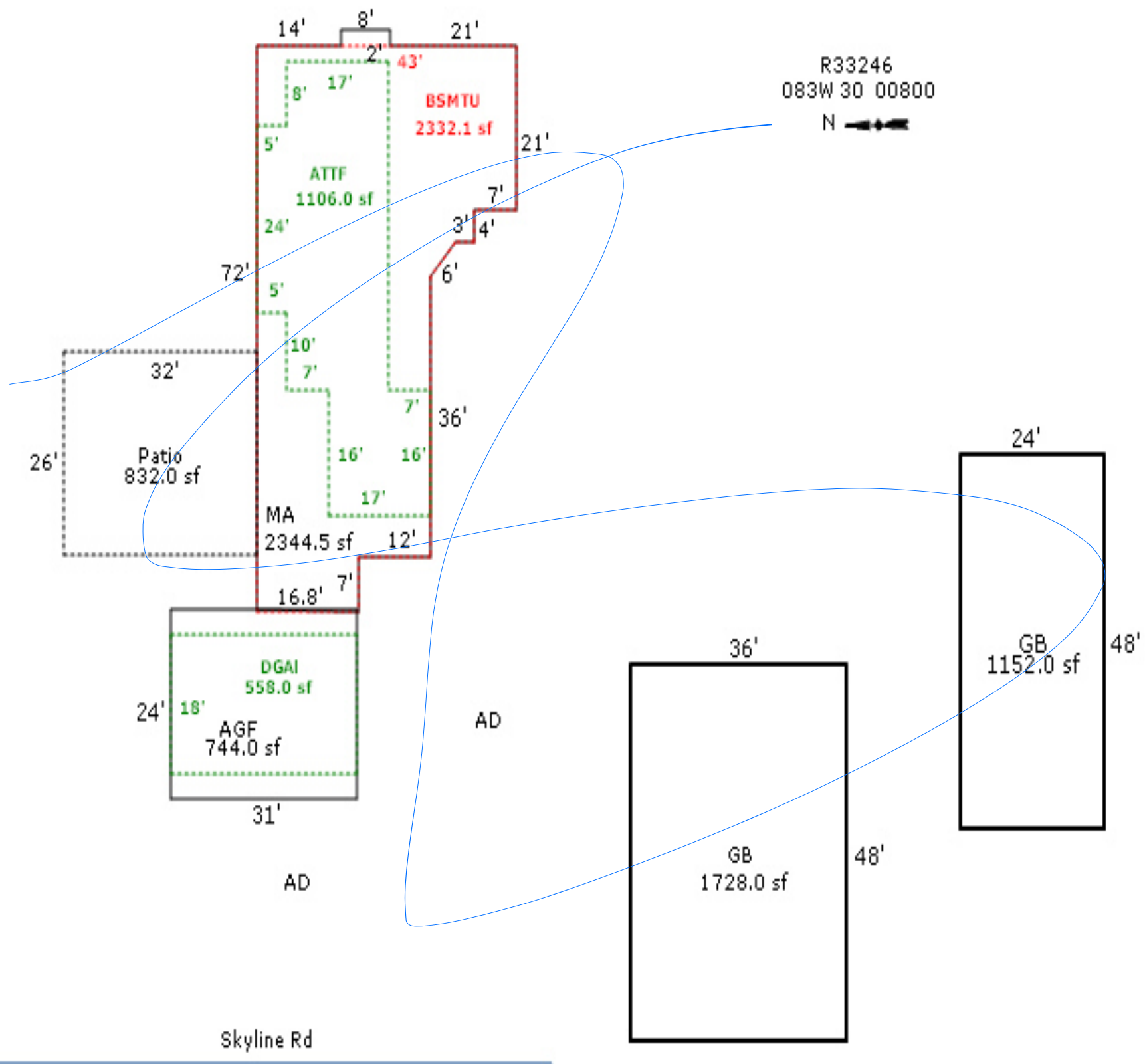

SKETCH/AREA TABLE ADDENDUM

SUBJECT INFO

File No.: 533246 Parcel No.: 083W30 00800
 Property Address: 7934 SKYLINE RD S
 City: SALEM County: MARION State: OR ZipCode: 97306
 Owner:
 Client: Client Address:
 Appraiser Name: Inspection Date:

SKETCH

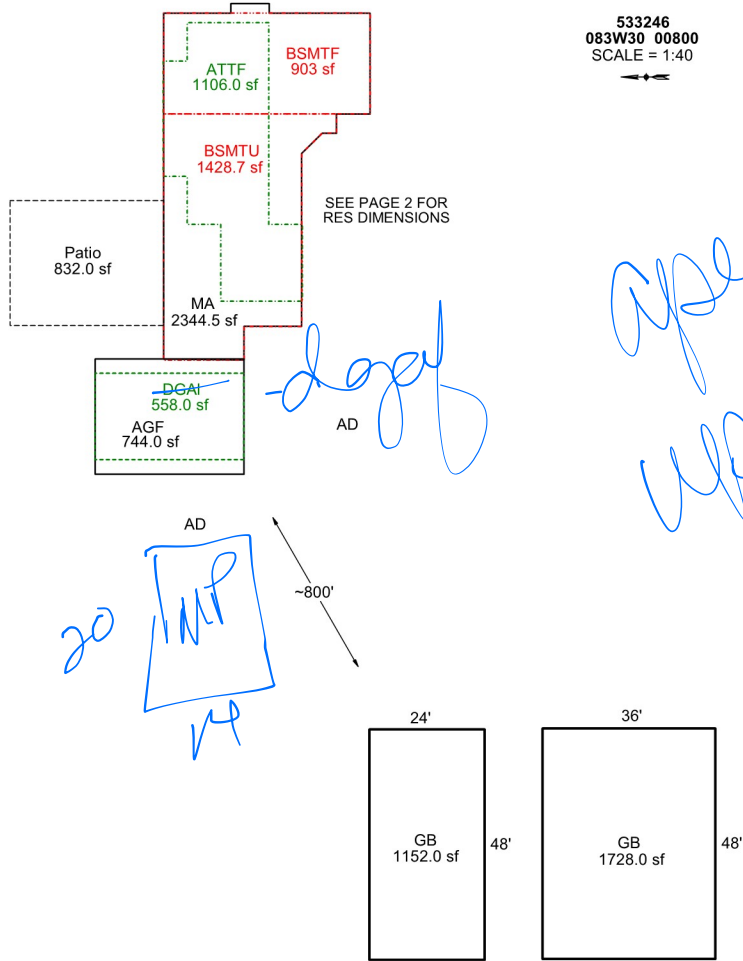

Sketch by Apex Sketch

AREA CALCULATIONS SUMMARY

Code	Description	Factor	Net Size	Perimeter	Net Totals
GBA1	GB	1.0	1152.0	144.0	
	GB	1.0	1728.0	168.0	2880.0
GLA1	MA	1.0	2344.5	231.8	2344.5
GLA2	ATTF	1.0	1106.0	174.0	1106.0
BSMT	BSMTU	1.0	1428.7	172.0	
	BSMTF	1.0	903.0	128.0	2331.7
GAR	AGF	1.0	744.0	110.0	
	DGAI	1.0	558.0	98.0	1302.0
P/P	Patio	1.0	832.0	116.0	832.0
	Net LIVABLE	cnt	2 (rounded)		3,451
	Net BUILDING	cnt	2 (rounded)		2,880

COMMENT TABLE 1

Apex 4/18/2011Jane
 UPDATED BY CJURAN 08/21/2023 555-23-003542

COMMENT TABLE 2

COMMENT TABLE 3

SKETCH/AREA TABLE ADDENDUM

SUBJECT INFO

File No.: 533246 Parcel No.: 083W30 00800
 Property Address: 7934 SKYLINE RD S
 City: SALEM County: MARION State: OR ZipCode: 97306
 Owner:
 Client: Client Address:
 Appraiser Name: Inspection Date:

SKETCH

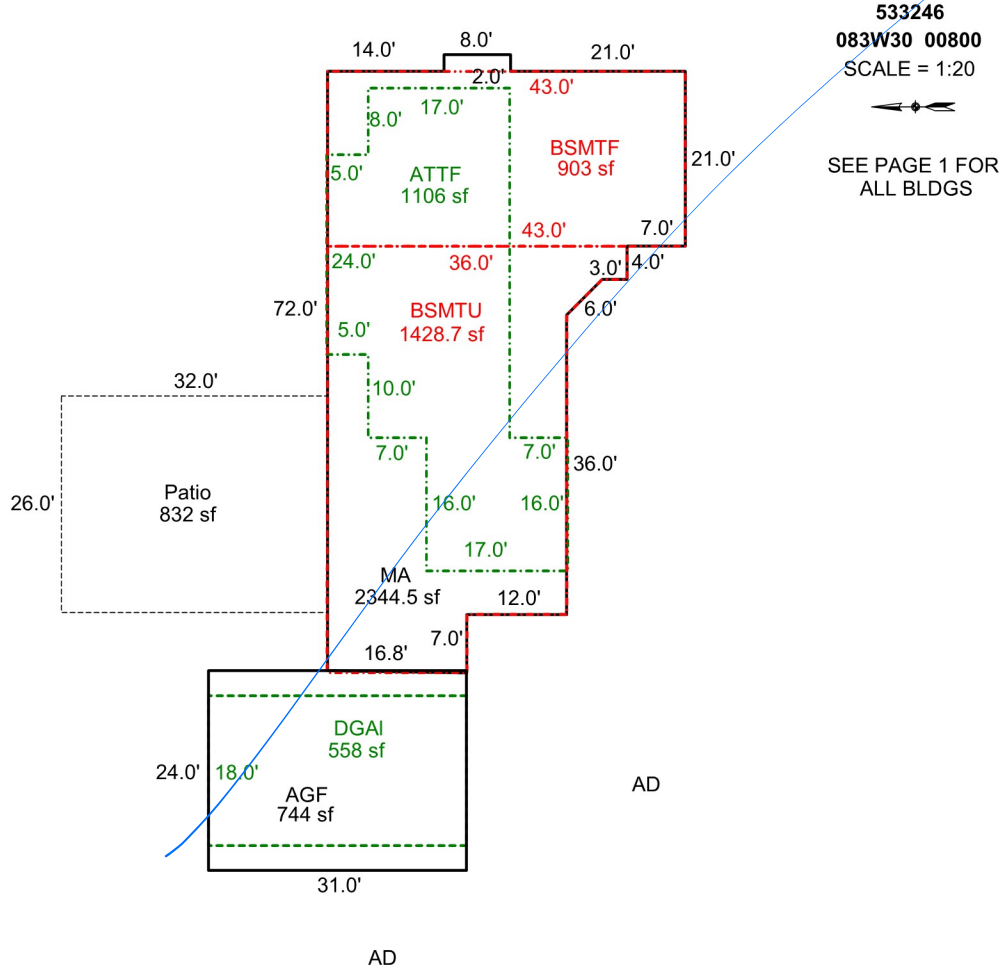

AREA CALCULATIONS SUMMARY

Code	Description	Factor	Net Size	Perimeter	Net Totals
GLA1	MA	1.0	2344.5	231.8	2344.5
GLA2	ATTF	1.0	1106.0	174.0	1106.0
BSMT	BSMTF	1.0	903.0	128.0	
	BSMTU	1.0	1428.7	172.0	2331.7
GAR	DGA	1.0	558.0	98.0	
	AGF	1.0	744.0	110.0	1302.0
P/P	Patio	1.0	832.0	116.0	832.0

COMMENT TABLE 1

Apex 4/18/2011Jane
 UPDATED BY CJURAN 08/21/2023 555-23-003542

COMMENT TABLE 2

COMMENT TABLE 3

Net LIVABLE cnt 2 (rounded) 3,451



Skyline

ine Rd S

000100

Area
Area: 3.88 Acres
Perimeter: 1777.6 Feet

Wilkerson Creek

083W3000000800

