

Acct ID: 535548 MTL: 092W230000500 Date: 2/2/24 Appr: MDL Prop Class: 551 RMV Prop Class: 551
 Situs: 8142 OKEY LN SE TURNER OR 97392 MaSaNh: 07 06 000 Unit: 57751 Year: 2023
 Last Date Appraised: 01/28/2021 Appraiser: MATT LORD Retag: Y N Tag info: 2024 - Tags/Permit (Addition)
 Owner: STRAWN, RANDALL DARIN Roll Type: R
 Cycle: Tag Sales Verification Other: _____ Inspection level: 1 2 3 4 LCB TTO INSP AV: 162073
 RMV Land: 324890 RMV Imp: 233750 RMV Total: 558640 MAV: 126590 MSAV: 35483 SAV: 87392
 Comment: LEVEL 2 1.28.21 CL10// .. dated

Notations 24-25: SFD Addition 23-003473 / New Bath / Kitchen moved to Addition

RP/MS	Code	Description
RP	ZONED	FARM EFU ZONED

OSDs

Count	Code	Description	RMV	Code Area	Exception
1	SAN	SA OSD - NO LANDSCAPE	30000	05545	0

Land

Site: 1	Code Area: 05545	Size: 1.00 Acres	Use Code: 005	Zone: REST	SAV Use: 011	Exception: 0
Class:	Value Source: Farm Homesite	Description:			RMV: 21970	Exception: Y N
Adjustment(s):	GSOIL, IRR		Fire Patrol:	Description:		
Comments: Liability year - 2009 / 18-19: SV #10 CHG OSD //2-16-07 (GW39): Change from 008 to 007.						
Site: 2	Code Area: 05545	Size: 10.80 Acres	Use Code: 005	Zone: REST	SAV Use: 011	Exception: 0
Class: 2BI	Value Source: Farm Use - EFU	Description: TWO BENCH IRR			RMV: 272920	Exception: Y N
Adjustment(s):	GSOIL, IRR		Fire Patrol:	Description:		
Comments: Liability year - 1980 / 550040						

Improvements - Residence / Manufactured Structures

Bldg: 1	Code Area: 05545	Stat Class: 131 <u>141</u>	Year Blt: 1948	Eff Year Blt: 1998	Sq.Ft: 960	% Complete: 100
Desc: One Story Only					Dimensions:	RMV: 146490
Func Obsc: 100	Econ %: 100	Other %: 100	Exception: 0	Adjust:	Adjust RMV: 0	

Floors

Type	Class	Display Group	Floor Size	Beds	Baths	Yr Blt	Eff Yr Blt	Inventory	Exception
First Floor	3	Finished	960	2	FB-1	1948	1998	HVAC, ROOF, KIT-, BATH - 1	Y N

Accessories

Description	Class	Size SqFt	Eff Yr Blt	RMV	Quantity	Exception
PATIO	3	216	1998	1045	1	Y N
PATIO	3	448	1998	2168	1	Y N
ROOF EXTENSION OR PATIO COVER	3	216	1998	5512	1	Y N

Bldg: 5	Code Area: 05545	Stat Class: 138	Year Blt: 1948	Eff Year Blt: 2004	Sq.Ft: 0	% Complete: 100
Desc: Res other improvements					Dimensions:	RMV: 36480
Func Obsc: 100	Econ %: 100	Other %: 100	Exception: 0	Adjust:	Adjust RMV: 0	

Floors

Type	Class	Display Group	Floor Size	Beds	Baths	Yr Blt	Eff Yr Blt	Inventory	Exception
Garage Detached	3	Finished	484	0	0	1948	2004	ROOF	Y N

Accessories

Description	Class	Size SqFt	Eff Yr Blt	RMV	Quantity
No accessory data available					

Improvements - Accessory Buildings

Bldg: 2	Code Area: 05545	Stat Class: 351	Year Blt: 1990	Eff Year Blt: 1990	Sq.Ft: 1440	% Complete: 100
Desc: General Purpose Building (GB)					Dimensions: 60x24	RMV: 9360
Func Obsc: 100	Econ %: 100	Other %: 100	Exception: 0	Adjust:	Adjust RMV: 0	

Floors

Type	Class	Display Group	Floor Size	Beds	Baths	Yr Blt	Eff Yr Blt	Inventory	Exception
General Purpose Bldg	4	Finished	1440	2	0	1990	1990	FAIR	Y N

Accessories

Description	Class	Size SqFt	Eff Yr Blt	RMV	Quantity
No accessory data available					

Bldg: 3 Code Area: 05545 Stat Class: 354 Year Blt: 1976 Eff Year Blt: 1976 Sq.Ft: 384 % Complete: 100
 Desc: Lean-to Light (LTL) Dimensions: 24x16 RMV: 0
 Func Obsc: 0 Econ %: 100 Other %: 100 Exception: 0 Adjust: Adjust RMV: 0

Floors

Type	Class	Display Group	Floor Size	Beds	Baths	Yr Blt	Eff Yr Blt	Inventory
Lean-to Light Duty	4	Finished	384	0	0	1976	1976	Exception: Y N

Accessories

Description	Class	Size SqFt	Eff Yr Blt	RMV	Quantity
No accessory data available					

Bldg: 4 Code Area: 05545 Stat Class: 341 Year Blt: 1971 Eff Year Blt: 1971 Sq.Ft: 384 % Complete: 100
 Desc: Multi Purpose Shed (MP) Dimensions: 24x16 RMV: 0
 Func Obsc: 0 Econ %: 100 Other %: 100 Exception: 0 Adjust: Adjust RMV: 0

Floors

Type	Class	Display Group	Floor Size	Beds	Baths	Yr Blt	Eff Yr Blt	Inventory
Multi-Purpose Bldg	4	Finished	384	0	0	1971	1971	Exception: Y N

Accessories

Description	Class	Size SqFt	Eff Yr Blt	RMV	Quantity
No accessory data available					

Bldg: 6 Code Area: 05545 Stat Class: 351 Year Blt: 2019 Eff Year Blt: 2019 Sq.Ft: 1728 % Complete: 100
 Desc: General Purpose Building (GB) Dimensions: 48x36 RMV: 41420
 Func Obsc: 100 Econ %: 100 Other %: 100 Exception: 0 Adjust: Adjust RMV: 0

Floors

Type	Class	Display Group	Floor Size	Beds	Baths	Yr Blt	Eff Yr Blt	Inventory
General Purpose Bldg	5	Finished	1728	0	0	2019	2019	FAIR Exception: Y N

Accessories

Description	Class	Size SqFt	Eff Yr Blt	RMV	Quantity
No accessory data available					

Bldg: 7 Code Area: 05545 Stat Class: 353 Year Blt: 2019 Eff Year Blt: 2019 Sq.Ft: 864 % Complete: 100
 Desc: Machine Shed (MS) Dimensions: 24x36 RMV: 0
 Func Obsc: 0 Econ %: 100 Other %: 100 Exception: 0 Adjust: Adjust RMV: 0

Floors

Type	Class	Display Group	Floor Size	Beds	Baths	Yr Blt	Eff Yr Blt	Inventory
Machine Shed	5	Finished	864	0	0	0	2019	Exception: Y N

Accessories

Description	Class	Size SqFt	Eff Yr Blt	RMV	Quantity
No accessory data available					

Bldg: 8 Code Area: 05545 Stat Class: 354 Year Blt: 1976 Eff Year Blt: 1976 Sq.Ft: 384 % Complete: 100
 Desc: Lean-to Light (LTL) Dimensions: RMV: 0
 Func Obsc: 0 Econ %: 100 Other %: 100 Exception: 0 Adjust: Adjust RMV: 0

Floors

Type	Class	Display Group	Floor Size	Beds	Baths	Yr Blt	Eff Yr Blt	Inventory
Lean-to Light Duty	4	Finished	384	0	0	1976	1976	Exception: Y N

Accessories

Description	Class	Size SqFt	Eff Yr Blt	RMV	Quantity
No accessory data available					

ADD
 MP
 8x12
 1971
 No Exception

ACCOUNT # _____ DATE: _____ RMV CLASS _____ PROP CLASS _____
 MTL _____ APPR _____ TAG Y N _____
 COMMENTS: _____

RESIDENCE / MANUFACTURED STRUCTURES

ACCESSORY IMPROVEMENTS / OUTBUILDINGS

STAT 4 QLTY + - FLOOR MA
 AREA 1600 EFF AREA 1600 BED 1
 ROOF + HVAC +
 BATH PKG: 1 BATH _____ BATH + _____ 1/2 BTH
 FIREPLACE: 1
 KITCHEN - +
 YR BLT 2023 EFF YR 2023 ECON _____
 % COMP 75 % GOOD _____ FUNC _____
 EXCEPT Y N LUMP SUM: _____
 MISC: _____
 YI CLASS _____ F G A E
 SKIRT + LIN FT _____
 COMMENT: _____

STAT _____ QLTY + - FLOOR _____
 AREA _____ EFF AREA _____ BED _____
 ROOF + HVAC +
 BATH PKG: _____ BATH _____ BATH + _____ 1/2 BTH
 FIREPLACE: _____
 KITCHEN - +
 YR BLT _____ EFF YR _____ ECON _____
 % COMP _____ % GOOD _____ FUNC _____
 EXCEPT Y N LUMP SUM: _____
 MISC: _____
 YI CLASS _____ F G A E
 SKIRT + LIN FT _____
 COMMENT: _____

STAT _____ QLTY + - FLOOR _____
 AREA _____ EFF AREA _____ BED _____
 ROOF + HVAC +
 BATH PKG: _____ BATH _____ BATH + _____ 1/2 BTH
 FIREPLACE: _____
 KITCHEN - +
 YR BLT _____ EFF YR _____ ECON _____
 % COMP _____ % GOOD _____ FUNC _____
 EXCEPT Y N LUMP SUM: _____
 MISC: _____
 YI CLASS _____ F G A E
 SKIRT + LIN FT _____
 COMMENT: _____

TYPE MP
 STAT / CLASS H
 SIZE 96
822
 FAIR
AVERAGE
 GOOD
 EXCELLENT
 BATH _____
 YR BLT 1971
 EFF YR 1971
 % COMP _____
 EXCEPT Y N
 MISC: _____
 COMMENT: Inventory

TYPE _____
 STAT / CLASS _____
 SIZE _____
 FAIR
 AVERAGE
 GOOD
 EXCELLENT
 BATH _____
 YR BLT _____
 EFF YR _____
 % COMP _____
 EXCEPT Y N
 MISC: _____
 COMMENT: _____

TYPE _____
 STAT / CLASS _____
 SIZE _____
 FAIR
 AVERAGE
 GOOD
 EXCELLENT
 BATH _____
 YR BLT _____
 EFF YR _____
 % COMP _____
 EXCEPT Y N
 MISC: _____
 COMMENT: _____

TYPE _____
 STAT / CLASS _____
 SIZE _____
 FAIR
 AVERAGE
 GOOD
 EXCELLENT
 BATH _____
 YR BLT _____
 EFF YR _____
 % COMP _____
 EXCEPT Y N
 MISC: _____
 COMMENT: _____

TYPE _____
 STAT / CLASS _____
 SIZE _____
 FAIR
 AVERAGE
 GOOD
 EXCELLENT
 BATH _____
 YR BLT _____
 EFF YR _____
 % COMP _____
 EXCEPT Y N
 MISC: _____
 COMMENT: _____

TYPE _____
 STAT / CLASS _____
 SIZE _____
 FAIR
 AVERAGE
 GOOD
 EXCELLENT
 BATH _____
 YR BLT _____
 EFF YR _____
 % COMP _____
 EXCEPT Y N
 MISC: _____
 COMMENT: _____

Percent Complete Form

Account # _____

Additions

New Homes

		<u>No Basement</u>		<u>Basement</u>	
% Item	% Sum	% Item	% Sum	% Item	% Sum
3%		Plans/Survey	3%	3%	
2%	0%	Excavation	2%	4%	0%
3%		Foundation	3%	10%	
35%	45%	Framing	14%	20%	35%
8%	50%	Trusses	7%	30%	40%
7%	60%	Roofing	7%	35%	45%
7%	65%	Windows/Ext Doors	7%	45%	55%
5%	70%	Siding	5%	50%	60%
4%	75%	Plumbing Rough-In	4%	55%	65%
3%		Electrical Rough-In	3%	58%	
2%		Heating Rough-In	2%	60%	
	80%	Heating Unit	1%	61%	
3%		Insulation	3%	64%	
5%	85%	Drywall (Finished)	5%	69%	70%
2%	90%	Paint Interior	2%	71%	75%
2%		Paint Exterior	2%	73%	
		Cabinets	6%	79%	80%
2%		Electrical Fixtures	3%	82%	
2%	95%	Plumbing Fixtures	4%	86%	85%
3%		Floor Coverings & Countertops	7%	93%	90%
2%	100%	Interior Trim Carpentry	7%	100%	95%
		Porch/Entry/Stoop	2%	100%	100%
		Finish Grade	1%	100%	100%

APPR _____ Date 2/1/14 YR For 24-25 % COMP 75%
 APPR _____ Date _____ YR For _____ % COMP _____
 APPR _____ Date _____ YR For _____ % COMP _____
 APPR _____ Date _____ YR For _____ % COMP _____

Percent Complete Form

Account # _____

Gut & Remodels

Interior Trim Carpentry	7%	90%
Floor Coverings & Countertops	7%	85%
Plumbing Fixtures	4%	80%
Electrical Fixtures	3%	80%
Cabinets	6%	75%
Drywall (Finished)	5%	70%
Insulation	3%	65%

APPR _____ Date _____ YR For _____ % COMP _____
 APPR _____ Date _____ YR For _____ % COMP _____
 APPR _____ Date _____ YR For _____ % COMP _____
 APPR _____ Date _____ YR For _____ % COMP _____

Outbuilding Type: _____

	% Item	% Sum
Excavation/Foundation	10%	40%
Floor - Concrete/Wood	30%	
Walls - Framing	10%	65%
Walls - Covering/Siding	15%	
Roof - Framing/Trusses	15%	
Roof - Sheathing	5%	95%
Roof - Cover	10%	
Doors & Windows	5%	100%

APPR _____ Date _____ YR For _____ % COMP _____
 APPR _____ Date _____ YR For _____ % COMP _____
 APPR _____ Date _____ YR For _____ % COMP _____
 APPR _____ Date _____ YR For _____ % COMP _____

SKETCH/AREA TABLE ADDENDUM

SUBJECT INFO

File No.: 535548 Parcel No.: 092W23 00500
 Property Address: 8142 OKEY LN SE
 City: TURNER County: MARION State: OR ZipCode: 97392
 Owner:
 Client: Client Address:
 Appraiser Name: Inspection Date:

SKETCH

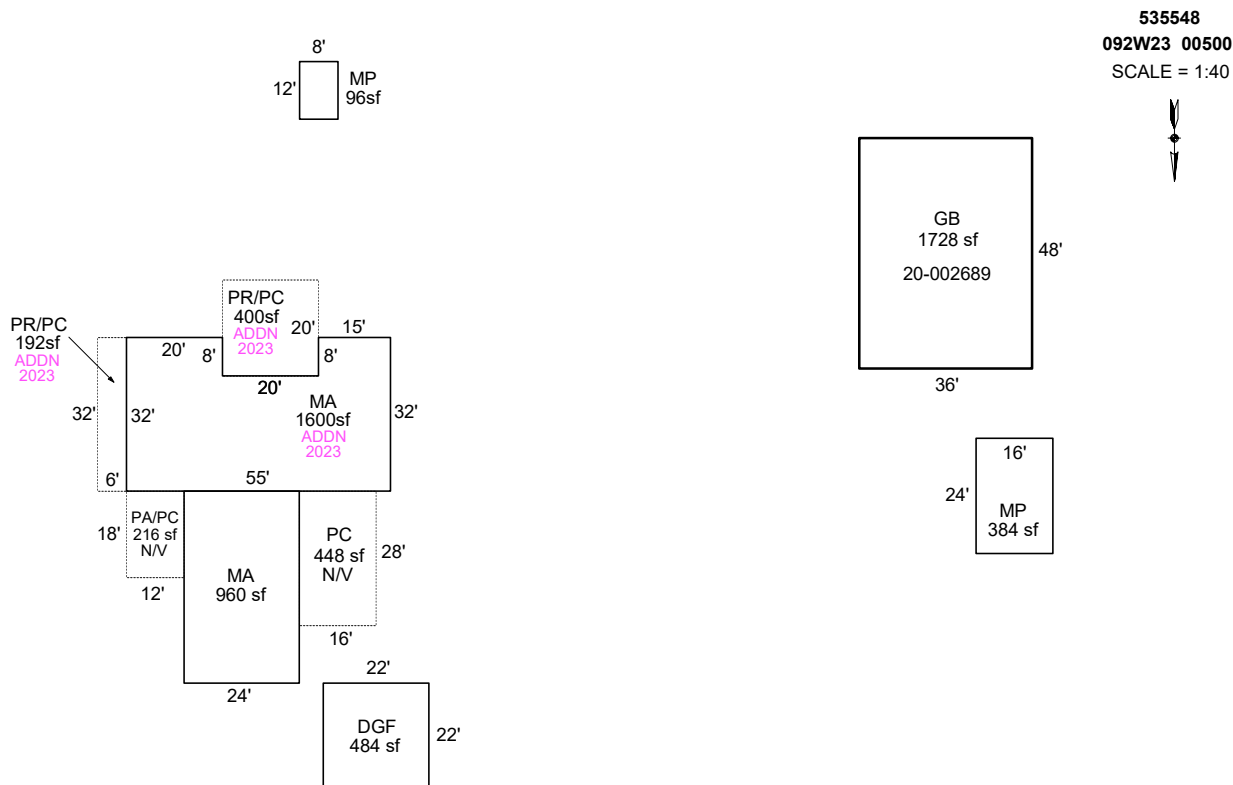

Sketch by Apex Sketch

AREA CALCULATIONS SUMMARY						COMMENT TABLE 1			
Code	Description	Factor	Net Size	Perimeter	Net Totals				
GBA1	DGF	1.0	484.0	88.0	2692.0	DRAWN BY JRONDEMA 6/7/18 UPDATED BY JRONDEMA 8/15/18 UPDATED BY JRONDEMA 4/1/19 UPD BY PHU 10.08.20 / 20-002689 UPDATED BY CJURAN 07/17/2023 555-23-003473 UPDATED BY CJURAN 03/06/2024			
	MP	1.0	384.0	80.0					
	GB	1.0	1728.0	168.0					
GLA1	MP	1.0	96.0	40.0	2560.0			COMMENT TABLE 2 COMMENT TABLE 3	
	MA	1.0	960.0	128.0					
P/P	MA	1.0	1600.0	190.0	592.0			12.02.19 CL #10: TAGS MDL 02/02/2024	
	PR/PC	1.0	192.0	76.0					
	PR/PC	1.0	400.0	80.0		TAGS L3			
	Net LIVABLE	cnt	2 (rounded)		2,560				
	Net BUILDING	cnt	4 (rounded)		2,692				

SKETCH/AREA TABLE ADDENDUM

SUBJECT INFO

File No.: 535548 Parcel No.: 092W23 00500
 Property Address: 8142 OKEY LN SE
 City: TURNER County: MARION State: OR ZipCode: 97392
 Owner:
 Client: Client Address:
 Appraiser Name: Inspection Date:

SKETCH

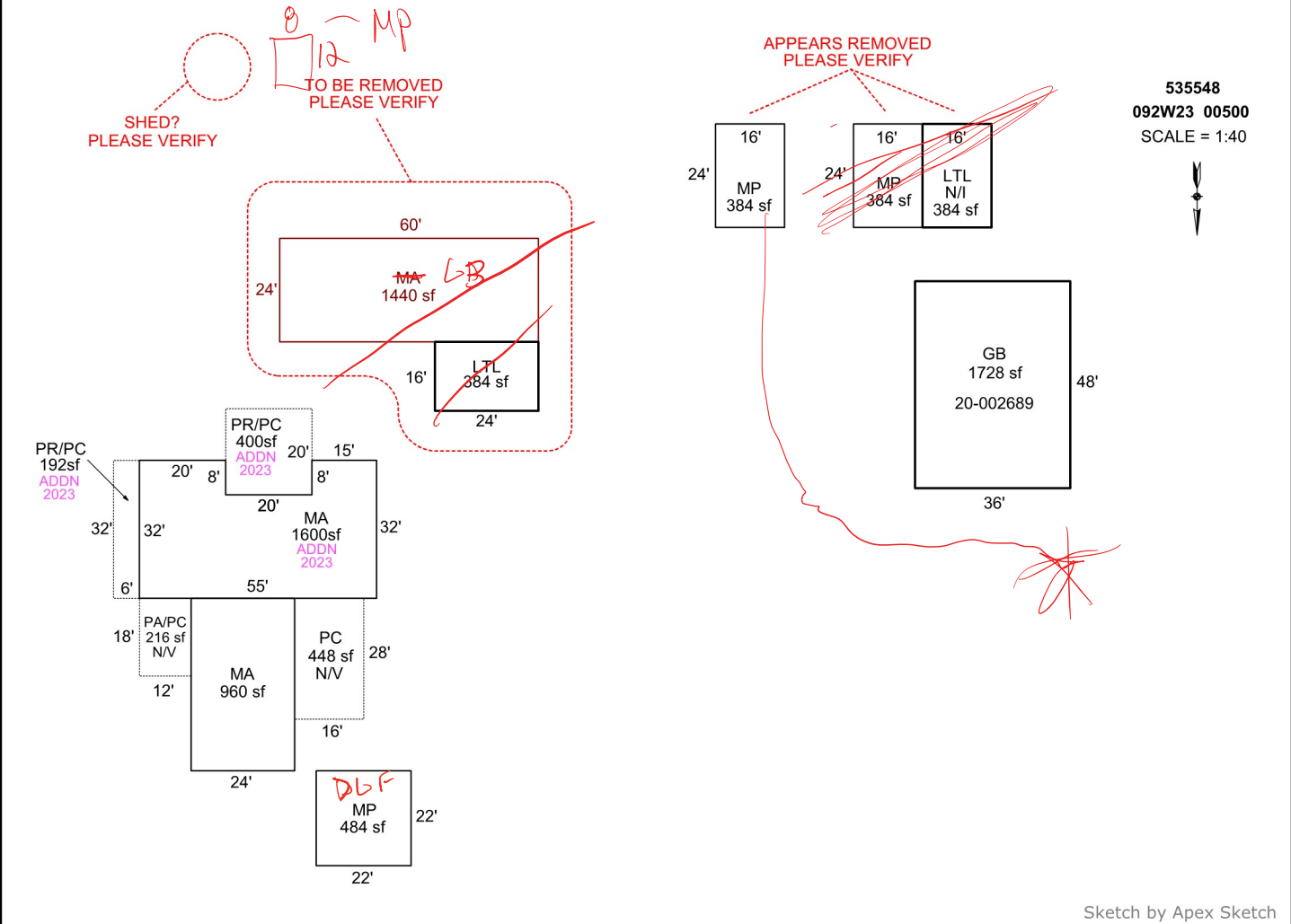

AREA CALCULATIONS SUMMARY

Code	Description	Factor	Net Size	Perimeter	Net Totals
GBA1	MP	1.0	484.0	88.0	
	LTL	1.0	384.0	80.0	
	MP	1.0	384.0	80.0	
	MP	1.0	384.0	80.0	
	LTL	1.0	384.0	80.0	
GLA1	GB	1.0	1728.0	168.0	3748.0
	MA	1.0	960.0	128.0	
	MA	1.0	1440.0	168.0	
P/P	MA	1.0	1600.0	190.0	4000.0
	PR/PC	1.0	192.0	76.0	
	PR/PC	1.0	400.0	80.0	592.0
	Net LIVABLE	cnt	3 (rounded)		4,000
	Net BUILDING	cnt	6 (rounded)		3,748

COMMENT TABLE 1

DRAWN BY JRONDEMA 6/7/18
 UPDATED BY JRONDEMA 8/15/18
 UPDATED BY JRONDEMA 4/1/19
 UPD BY PHU 10.08.20 / 20-002689
 UPDATED BY CJURAN 07/17/2023 555-23-003473

COMMENT TABLE 2

12.02.19 CL #10: TAGS

MDL 2/2/24

COMMENT TABLE 3

L3 TAG

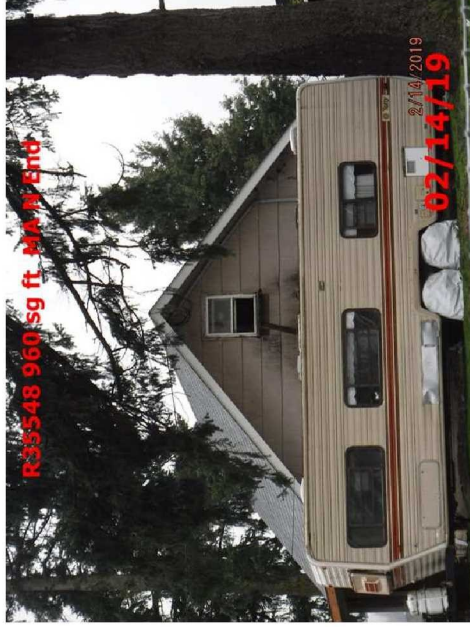



R35548 Gated Entry

2/14/2019
02/14/19



R35548 1440 Sgft MA E End N Side

2/14/2019
02/14/19



R35548 1440 sg ft MA W Side

2/14/2019
02/14/19

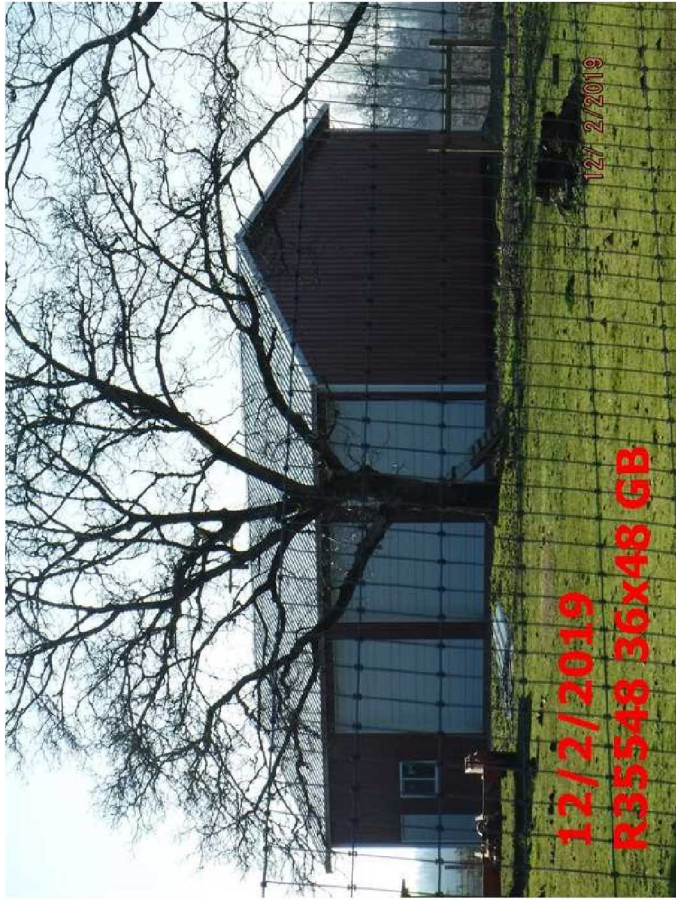



R35548 MA-MP
2021-01-28 17

