

SKETCH/AREA TABLE ADDENDUM

SUBJECT INFO

File No.: 598233 Parcel No.: 105E01BC10800
 Property Address: 360 BUTTE ST N
 City: DETROIT County: State: OR ZipCode:
 Owner:
 Client: Client Address:
 Appraiser Name: Inspection Date:

SKETCH

598233
105E01BC10800

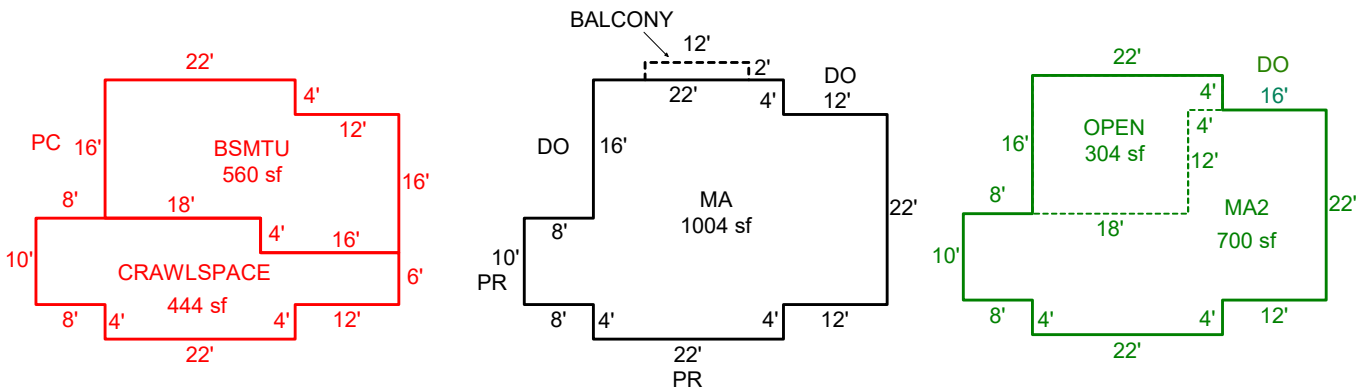

Sketch by ApexSketch

AREA CALCULATIONS SUMMARY

Code	Description	Factor	Net Size	Perimeter	Net Totals
GLA	MA	1.0	1004.0	144.0	1004.0
GLA2	MA2	1.0	700.0	144.0	700.0
BSMT	BSMTU	1.0	560.0	108.0	560.0
OTH	OPEN	1.0	304.0	76.0	
	CRAWLSPACE	1.0	444.0	112.0	748.0

COMMENT TABLE 1

DRAWN BY JT 8/4/23
 Updated by AE 9.5.24

COMMENT TABLE 2

COMMENT TABLE 3

Net LIVABLE cnt 2 (rounded) 1,704