

# SKETCH/AREA TABLE ADDENDUM

## SUBJECT INFO

File No.: 323854 Parcel No.: 093W10A 00503  
 Property Address: 10321 KISKA LN SE  
 City: JEFFERSON County: State: OR ZipCode: 97352  
 Owner:  
 Client: Client Address:  
 Appraiser Name: Inspection Date:

## SKETCH

**093W10A 00503  
323854**

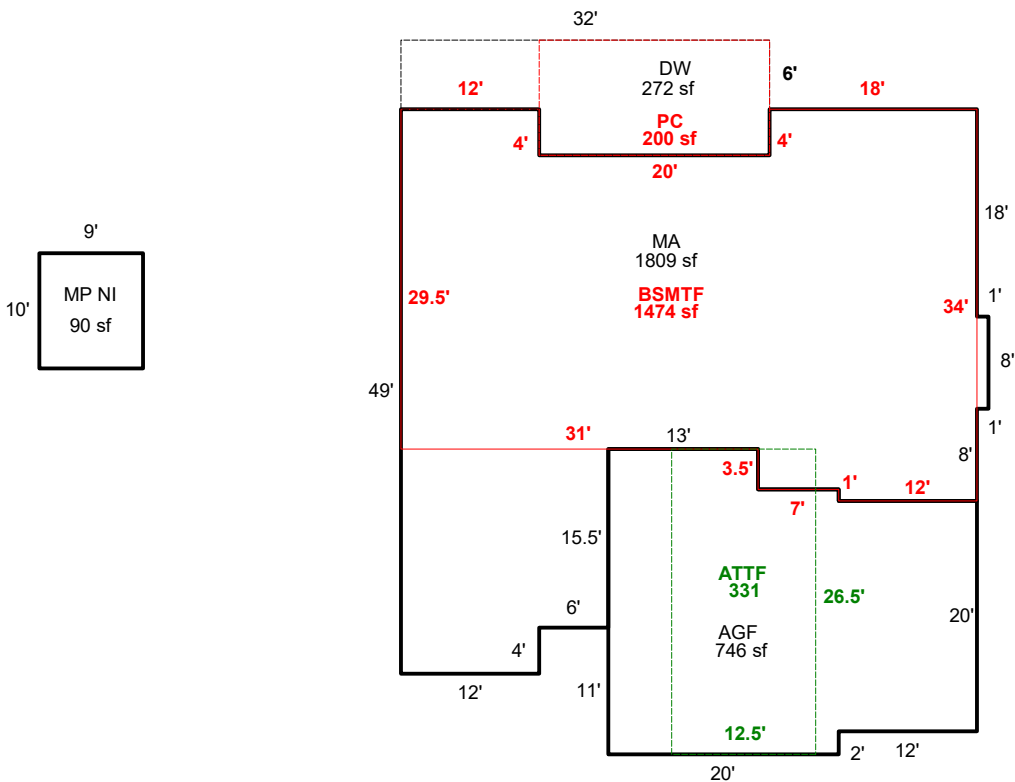

Sketch by ApexSketch

### AREA CALCULATIONS SUMMARY

Code	Description	Factor	Net Size	Perimeter	Net Totals
GBA3	MP NI	1	90	38	90
GLA0	BSMTF	1	1474	176	1474
GLA1	MA	1	1809	217	1809
GLA2	ATTF	1	331	78	331
GAR	AGF	1	746	117	746
P/P	DW	1	272	84	272
	PC	1	200	60	472
	Net LIVABLE	cnt	2 (rounded)		3,613
	Net BUILDING	cnt	1 (rounded)		90

### COMMENT TABLE 1

APEXED BY NRC 08/31/09  
 UPD BY WW 9.18.24

### COMMENT TABLE 2

#10 CL 9.13.18  
 MDL 4.11.23  
 WW 9.10.24

### COMMENT TABLE 3

CYCLE  
 TAG L4  
 CYCLE L3