

SKETCH/AREA TABLE ADDENDUM

SUBJECT INFO

File No.: 329045 Parcel No.: 082W02BB00900
 Property Address: 1982 PEBBLES LN SE
 City: Salem County: Marion State: OR ZipCode: 97317
 Owner:
 Client: Client Address:
 Appraiser Name: Inspection Date:

SKETCH

329045
082W02BB00900
SCALE=1:30

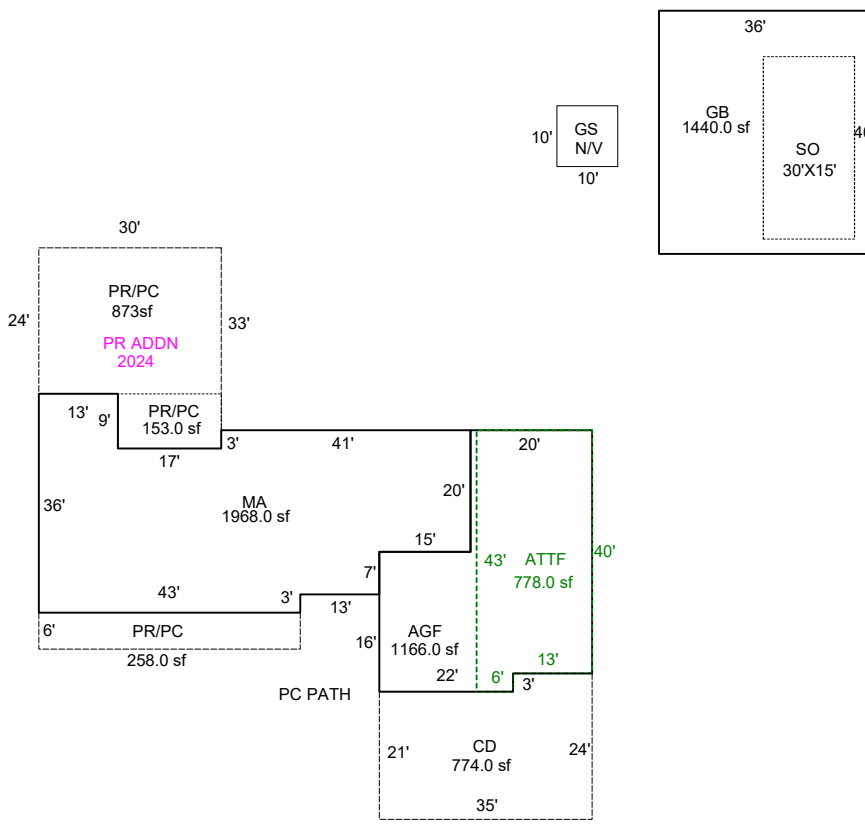

Sketch by ApexSketch

AREA CALCULATIONS SUMMARY						COMMENT TABLE 1					
Code	Description	Factor	Net Size	Perimeter	Net Totals						
GBA1	GB	1.0	1440.0	152.0	1440.0	APEXED BY NRC 06/08/2009 UPDATED BY JRONDEMA 7/3/17 UPD BY PH 10.21.19 UPDATED BY CLOBERG 09/20/24 24-006110 PR ADDN					
GLA1	MA	1.0	1968.0	220.0	1968.0						
GLA2	ATTF	1.0	778.0	124.0	778.0						
GAR	AGF	1.0	1166.0	156.0	1166.0						
YI1	CD	1.0	774.0	118.0							
	PR/PC	1.0	258.0	98.0							
	PR/PC	1.0	873.0	126.0	1905.0						
	Net LIVABLE	cnt	2 (rounded)		2,746	<table border="1" style="width: 100%; border-collapse: collapse;"> <thead> <tr> <th style="width: 50%;">COMMENT TABLE 2</th> <th style="width: 50%;">COMMENT TABLE 3</th> </tr> </thead> <tbody> <tr> <td>5.19.17 SR #94 CYCLE, NV 09.19.19 SR #94</td> <td>S.V.</td> </tr> </tbody> </table>		COMMENT TABLE 2	COMMENT TABLE 3	5.19.17 SR #94 CYCLE, NV 09.19.19 SR #94	S.V.
COMMENT TABLE 2	COMMENT TABLE 3										
5.19.17 SR #94 CYCLE, NV 09.19.19 SR #94	S.V.										
	Net BUILDING	cnt	1 (rounded)		1,440						