

SKETCH/AREA TABLE ADDENDUM

SUBJECT INFO

File No.: 333202 Parcel No.: 083W17DB00600
 Property Address: 5615 SKYLINE RD S
 City: SALEM County: State: OR ZipCode: 97306
 Owner:
 Client: Client Address:
 Appraiser Name: Inspection Date:

SKETCH

333202
083W17DB00600
SCALE: 1'=30'

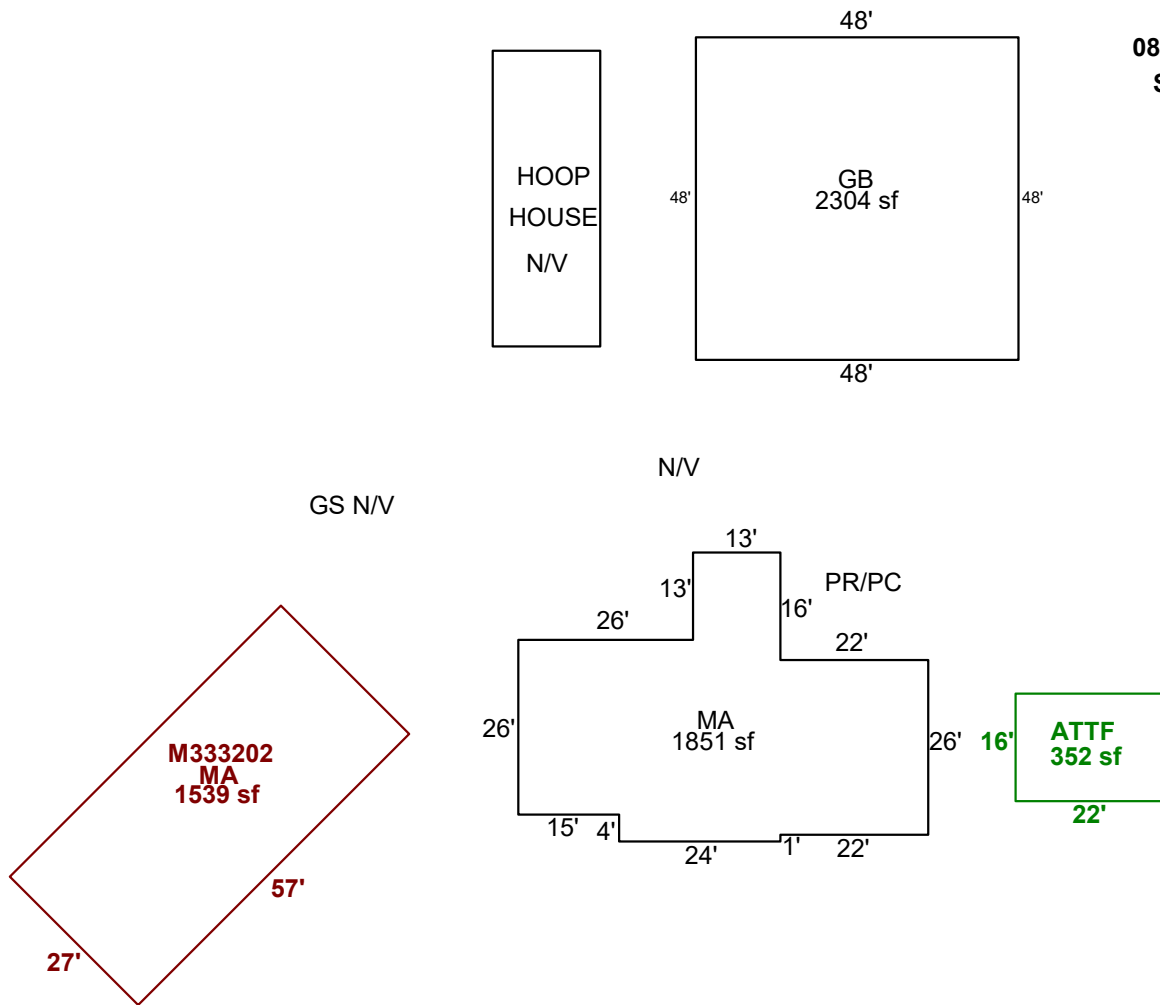

AREA CALCULATIONS SUMMARY					
Code	Description	Factor	Net Size	Perimeter	Net Totals
GBA1	GB	1.0	2304.0	192.0	2304.0
GLA1	MA	1.0	1851.0	208.0	
	MA	1.0	1539.0	168.0	3390.0
GLA2	ATTF	1.0	352.0	76.0	352.0
	Net LIVABLE	cnt	1 (rounded)		3,742
	Net BUILDING	cnt	0 (rounded)		2,304

COMMENT TABLE 1	
DRAWN 11/30/11 by Tina UPDATED BY JRONDEMA 9/19/17 UPDATED BY LK 9.20.24	
COMMENT TABLE 2	COMMENT TABLE 3
3.16.17 #101 CYCLE NV 9.12.24 CYCLE SH	