

# SKETCH/AREA TABLE ADDENDUM

## SUBJECT INFO

File No.: 596169 Parcel No.: 073W23BA10800  
 Property Address: 945 NORWAY ST NE  
 City: SALEM County: State: OR ZipCode: 97301  
 Owner:  
 Client: Client Address:  
 Appraiser Name: Inspection Date:

## SKETCH

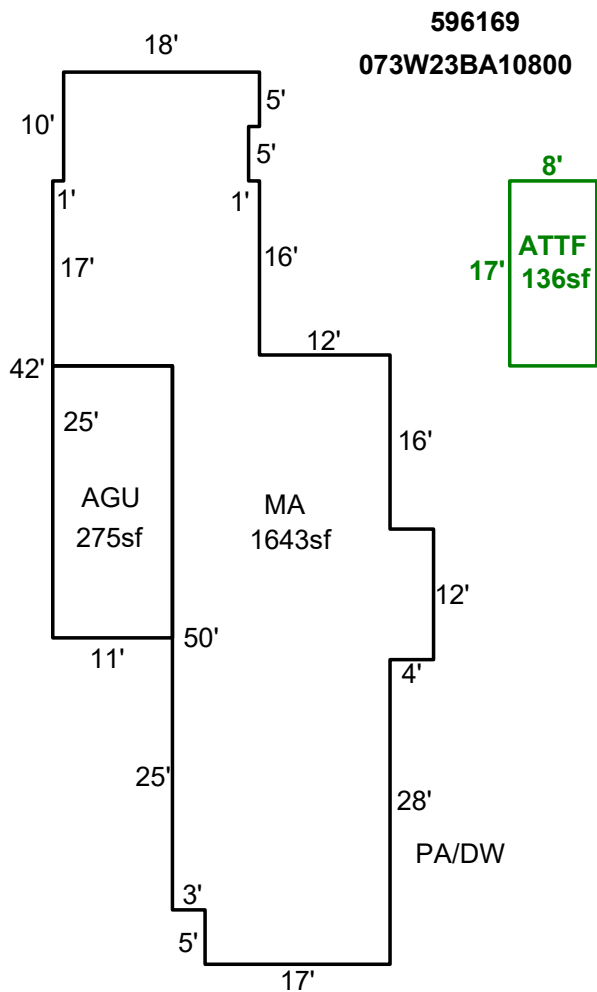

Sketch by ApexSketch

### AREA CALCULATIONS SUMMARY

Code	Description	Factor	Net Size	Perimeter	Net Totals
GLA1	MA	1.0	1643.0	236.0	1643.0
GLA2	ATTF	1.0	136.0	50.0	136.0
GAR	AGU	1.0	275.0	72.0	275.0

### COMMENT TABLE 1

APEX BY TB 01-28-08  
 UPDATED BY SH 1-22-09  
 UPDATED BY SRAGSDALE 9/9/14  
 UPDATED BY KMOORE 6/18/2020

### COMMENT TABLE 2

9/5/14 #4, CYCLE, NV  
 5/22/15 #72 NV SALES  
 6/11/20 96 CYCLE NV

### COMMENT TABLE 3

Net LIVABLE      cnt      2 (rounded)      1,779