

# SKETCH/AREA TABLE ADDENDUM

## SUBJECT INFO

File No.: 330105 Parcel No.: 082W11B 06400  
 Property Address: 3892 75TH AVE SE  
 City: Salem County: Marion State: OR ZipCode: 97317  
 Owner:  
 Client: Client Address:  
 Appraiser Name: Inspection Date: ,

## SKETCH

330105  
082W11B 06400  
SCALE=1:20

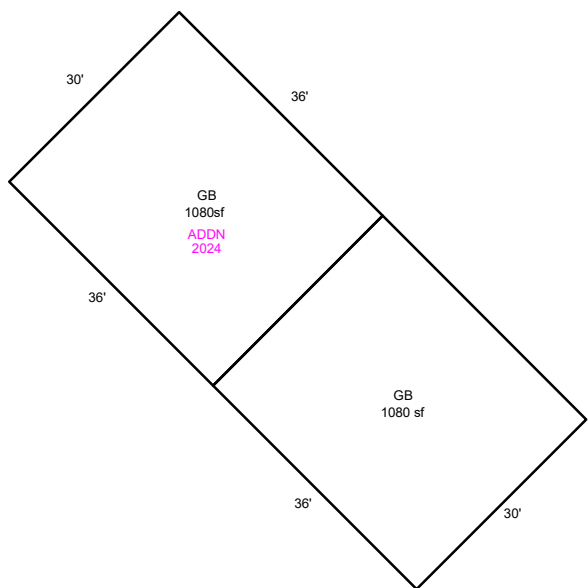
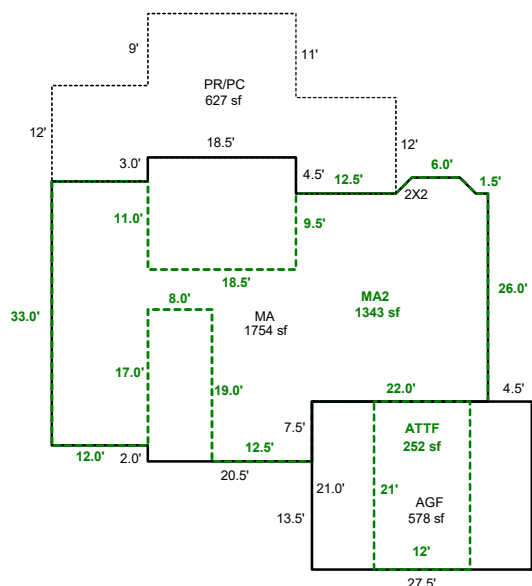

CD

Sketch by ApexSketch

### AREA CALCULATIONS SUMMARY

Code	Description	Factor	Net Size	Perimeter	Net Totals
GBA1	GB	1.0	1080.0	132.0	
	GB	1.0	1080.0	132.0	2160.0
GLA1	MA	1.0	1754.0	186.7	1754.0
GLA2	MA2	1.0	1343.0	233.7	
	ATTF	1.0	252.0	66.0	1595.0
GAR	AGF	1.0	577.5	97.0	577.5
P/P	PR/PC	1.0	627.0	137.0	627.0

### COMMENT TABLE 1

UPDATED BY JRONDEMA 12/2/15  
 UPDATED BY JRONDEMA 9/19/17  
 UPDATED BY CLOBERG 10/17/24 24-005998 GB ADDN

### COMMENT TABLE 2

1.20.16 #94 TAGS  
 8.25.17 SR #94 CYCLE, NV

### COMMENT TABLE 3

Net LIVABLE	cnt	3	(rounded)		3,349
Net BUILDING	cnt	2	(rounded)		2,160