

Acct ID: 529864 MTL: 082W15D000100 Date: 9-11-24 Appr: WW Prop Class: 401 RMV Prop Class: 401
 Situs: 7330 AUMSVILLE HWY SE SALEM OR 97317 MaSaNh: 07 06 000 Unit: 89376 Year: 2024

Last Date Appraised: 11/10/2014 Appraiser: MATT LORD Retag: Y N Tag info:

Owner: CAKARNIS, JEFFREY Roll Type: R

Cycle Tag Sales Verification Other: VET EXEMPT DQ Inspection level: 1 2 3 4 LCB TTO INSP AV: 259912

RMV Land: 243180 RMV Imp: 306330 RMV Total: 549510 MAV: 259912 MSAV: 0 SAV: 0

Comment:

update inv Rest man

Notations

No notation data available.

OSDs

Count	Code	Description	RMV	Code Area	Exception
1	MKTA	OSD - AVERAGE	45000	05550	0

Land

Site: 1 Code Area: 05550 Size: 2.00 Acres Use Code: 004 Zone: NREST SAV Use: Exception: 0
 Class: Value Source: Rural at MKT Description: 2BDSS RMV: 198180 Exception: Y N
 Adjustment(s): VWFR Fire Patrol: Description:
 Comments: 99-2000; REMOVE MS5, ADD GB6, PULL FROM MAINT .2002-03 REAPPRAISAL.

Improvements - Residence / Manufactured Structures

Bldg: 1 Code Area: 05550 Stat Class: 141 + Year Blt: 1977 Eff Year Blt: 1977 Sq.Ft: 1605 % Complete: 100
 Desc: One Story Only Dimensions: RMV: 273800
 Func Obsc: 100 Econ %: 100 Other %: 100 Exception: 0 Adjust: Adjust RMV: 0
1987
ROOF

Floors

Type	Class	Display Group	Floor Size	Beds	Baths	Yr Blt	Eff Yr Blt	Inventory	Exception
First Floor	4 +	Finished	1605	2	FB-2/ HB-1	1977	1977	BATH - 2, BTH - 1, KIT, ROOF, HVAC+, FP - 1	Exception: Y N

Accessories

Description	Class	Size SqFt	Eff Yr Blt	RMV	Quantity	Exception
ASPHALT DRIVEWAY	4	4100	2009	11439	1	Exception: Y N
DECK	4	850	1977	13090	1	Exception: Y N
PATIO	4	340	2005	1702	1	Exception: Y N

Improvements - Accessory Buildings

Bldg: 2 Code Area: 05550 Stat Class: 351 Year Blt: 1998 Eff Year Blt: 1998 Sq.Ft: 1728 % Complete: 100
 Desc: General Purpose Building (GB) Dimensions: 48x24 RMV: 27050
 Func Obsc: 100 Econ %: 100 Other %: 100 Exception: 0 Adjust: Adjust RMV: 0

Floors

Type	Class	Display Group	Floor Size	Beds	Baths	Yr Blt	Eff Yr Blt	Inventory	Exception
General Purpose Bldg	6	Finished	1152	0	0	1998	1998	AVG GOOD 576 EXCELLENT 576 BTH	Exception: Y N
Finished Office	6	Finished	576	0	FB-1/ HB-1	1998	1998	BTH - 1	Exception: Y N

Accessories

Description	Class	Size SqFt	Eff Yr Blt	RMV	Quantity
No accessory data available					

Bldg: 3 Code Area: 05550 Stat Class: 355 Year Blt: 2009 Eff Year Blt: 2009 Sq.Ft: 768 % Complete: 100
 Desc: Lean-to Heavy (LTH) LTL Dimensions: 48x16 RMV: 4480
 Func Obsc: 100 Econ %: 100 Other %: 100 Exception: 0 Adjust: Adjust RMV: 0

Floors

Type	Class	Display Group	Floor Size	Beds	Baths	Yr Blt	Eff Yr Blt	Inventory	Exception
Lean-to Heavy Duty	4	Finished	768	0	0	2009	2009	FAIR	Exception: Y N

Accessories

Description	Class	Size SqFt	Eff Yr Blt	RMV	Quantity
No accessory data available					

Bldg: 4 Code Area: 05550 Stat Class: 354 Year Blt: 2005 Eff Year Blt: 2005 Sq.Ft: 288 % Complete: 100
 Desc: Lean-to Light (LTL) Dimensions: RMV: 1000
 Func Obsc: 100 Econ %: 100 Other %: 100 Exception: 0 Adjust: Adjust RMV: 0

both made with corrugated fiberglass

Floors

Type	Class	Display Group	Floor Size	Beds	Baths	Yr Blt	Eff Yr Blt	Inventory	Exception: Y N
Lean-to Light Duty	4	Finished	288	0	0	2005	2005	FAIR	

Accessories

Description	Class	Size SqFt	Eff Yr Blt	RMV	Quantity
No accessory data available					



SKETCH/AREA TABLE ADDENDUM

Parcel No 082W15D 00100

File No R29864

SUBJECT	Property Address 7330 AUMSVILLE HWY SE			
	City SALEM	County MARION	State OR	Zip 97317
	Owner			
	Client			
	Appraiser Name			

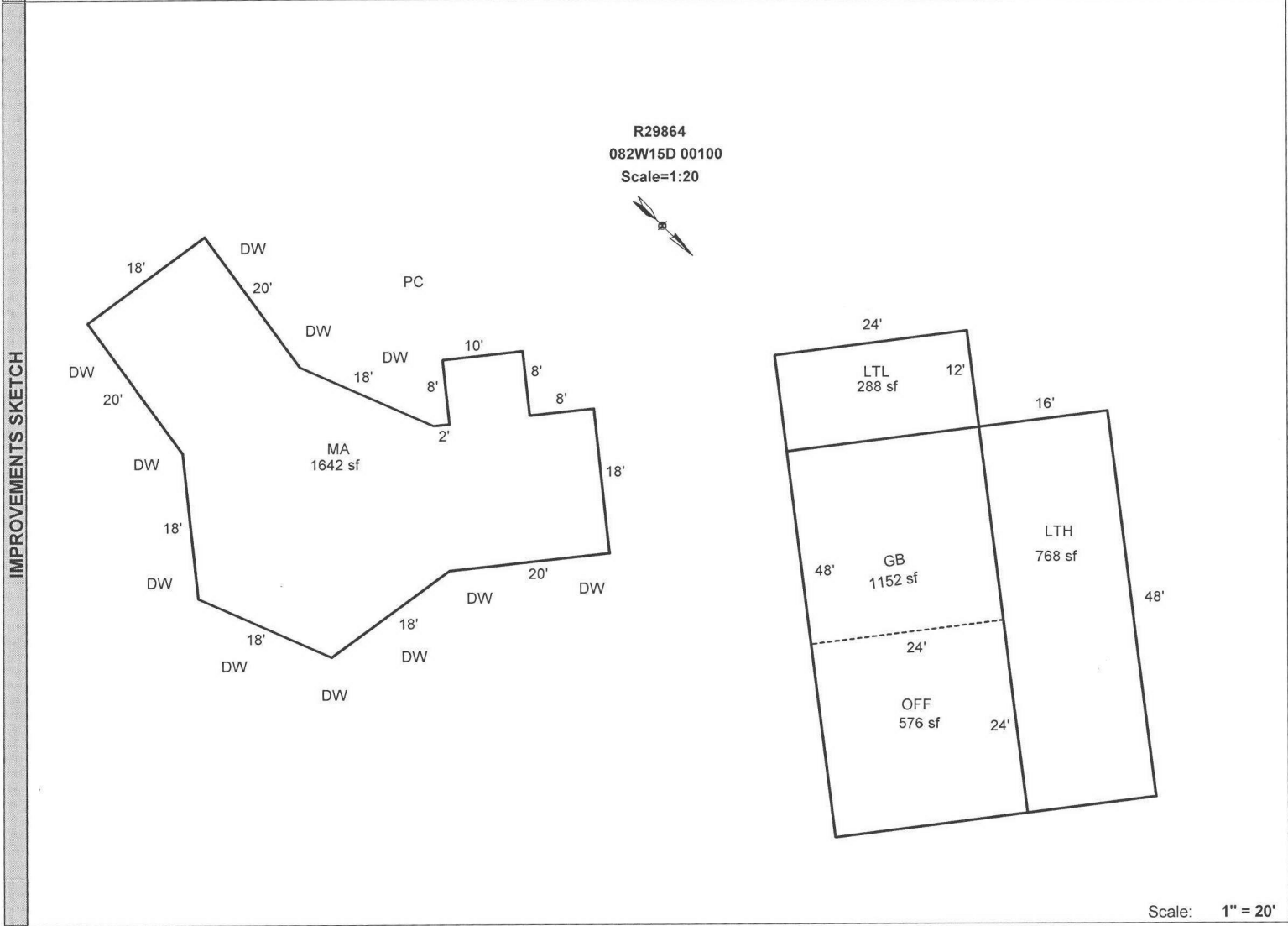

Scale: 1" = 20'

AREA CALCULATIONS	AREA CALCULATIONS SUMMARY				
	Code	Description	Factor	Net Size	Perimeter
	GLA1	MA	1.00	1642	204
		GB	1.00	1152	144
	GBA1	LTL	1.00	288	72
	LTH	1.00	768	128	
	OFF	1.00	576	96	
					2794
					1056
					576
					96
					2794
					1056
					576
					96
					2794
					1056
					576
					96
					2794
					1056
					576
					96
					2794
					1056
					576
					96
					2794
					1056
					576
					96
					2794
					1056
					576
					96
					2794
					1056
					576
					96
					2794
					1056
					576
					96
					2794
					1056
					576
					96
					2794
					1056
					576
					96
					2794
					1056
					576
					96
					2794
					1056
					576
					96
					2794
					1056
					576
					96
					2794
					1056
					576
					96
					2794
					1056
					576
					96
					2794
					1056
					576
					96
					2794
					1056
					576
					96
					2794
					1056
					576
					96
					2794
					1056
					576
					96
					2794
					1056
					576
					96
					2794
					1056
					576
					96
					2794
					1056
					576
					96
					2794
					1056
					576
					96
					2794
					1056
					576
					96
					2794
					1056
					576
					96
					2794
					1056
					576
					96
					2794
					1056
					576
					96
					2794
					1056
					576
					96
					2794
					1056
					576
					96
					2794
					1056
					576
					96
					2794
					1056
					576
					96
					2794
					1056
					576
					96
					2794
					1056
					576
					96
					2794
					1056
					576
					96
					2794
					1056
					576
					96
					2794
					1056
					576
					96
					2794
					1056
					576
					96
					2794
					1056
					576
					96
					2794
					1056
					576
					96
					2794
					1056
					576
					96
					2794
					1056
					576
					96
					2794
					1056
					576
					96
					2794
					1056
					576
					96
					2794
					1056
					576
					96
					2794
					1056
					576
					96
					2794
					1056
					576
					96
					2794
					1056
					576
					96
					2794
					1056
					576
					96
					2794
					1056
					576
					96
					2794
					1056
					576
					96
					2794
					1056
					576
					96
					2794
					1056
					576
					96
					2794
					1056
					576
					96
					2794
					1056
					576
					96
					2794
					1056
					576
					96
					2794
					1056
					576
					96
					2794
					1056
					576
					96
					2794
					1056
					576
					96
					2794
					1056

SKETCH/AREA TABLE ADDENDUM

SUBJECT INFO

File No.: R29866 Parcel No.: 082W15D 00400
 Property Address: 5536 72ND AVE SE
 City: SALEM County: MARION State: OR ZipCode: 97317
 Owner:
 Client: Client Address:
 Appraiser Name: Inspection Date:

SKETCH

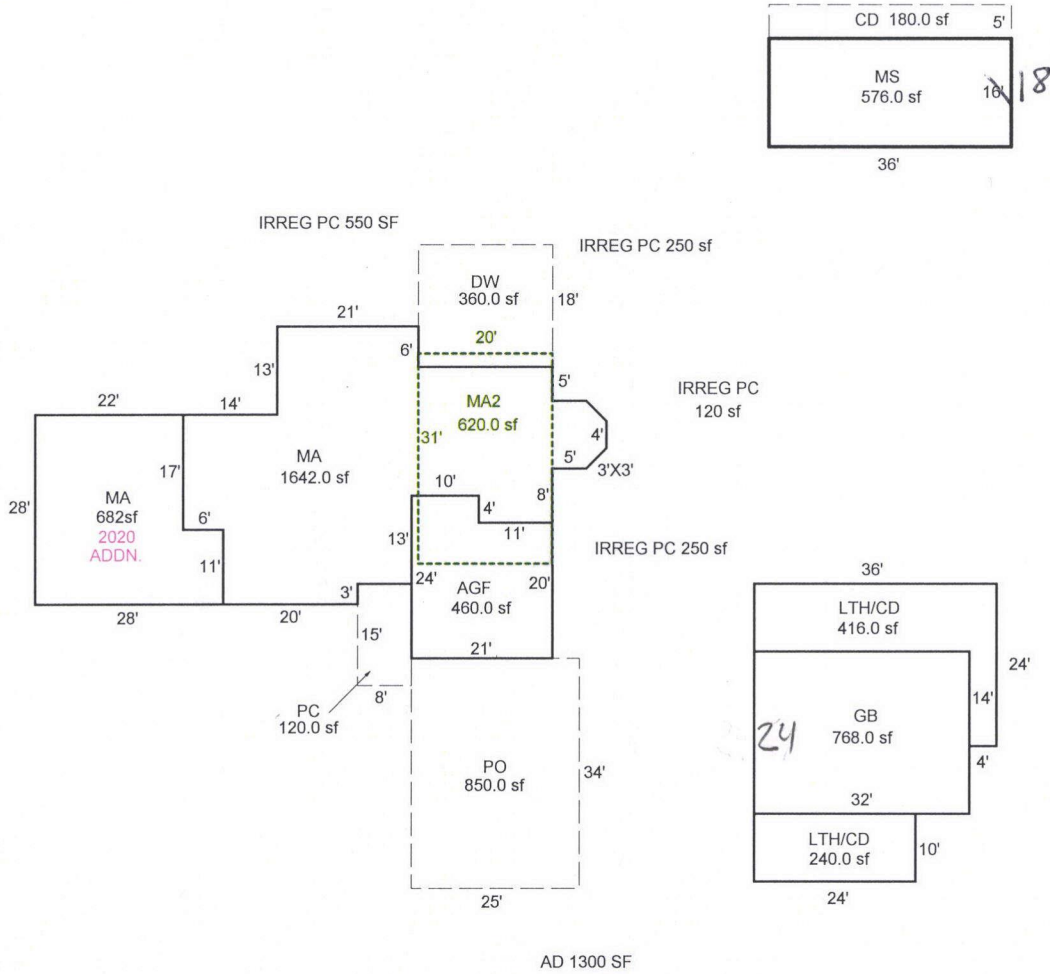

R29866
 082W15D 00400
 SCALE=1:20

Sketch by Apex Sketch

AREA CALCULATIONS SUMMARY

COMMENT TABLE 1

Code	Description	Factor	Net Size	Perimeter	Net Totals
GBA1	GB	1.0	768.0	112.0	
	LTH/CD	1.0	416.0	120.0	
	LTH/CD	1.0	240.0	68.0	
GLA1	MS	1.0	576.0	104.0	2000.0
	MA	1.0	1642.0	212.5	
GLA2	MA	1.0	682.0	112.0	2324.0
	MA2	1.0	620.0	102.0	620.0
GAR	AGF	1.0	460.0	90.0	460.0
YI1	DW	1.0	360.0	76.0	
	PO	1.0	850.0	118.0	
	PC	1.0	120.0	46.0	
	CD	1.0	240.0	68.0	
	CD	1.0	416.0	120.0	
	CD	1.0	180.0	82.0	2166.0
	Net LIVABLE	cnt	3 (rounded)		2,944
	Net BUILDING	cnt	4 (rounded)		2,000

2/22/17 BY CW
 UPD BY PH 08.20.19
 UPDATED BY CJURAN 06/03/2021

COMMENT TABLE 2

07.12.19 CL #10
 #10 CL 03/17/2021

9/1/21 T47 L2

COMMENT TABLE 3

CYCLE
 TAGS L2

TAGS