

Acct ID: 533711 MTL: 084W24A000300 Date: 8.13.24 Appr: WW Prop Class: 451 RMV Prop Class: 451
 Situs: 4112 VITAE SPRINGS RD S SALEM OR 97302 MaSaNh: 06 06 000 Unit: 30001 Year: 2024
 Last Date Appraised: 09/15/2010 Appraiser: WENDY WILLIAMS Retag: Y N Tag info:
 Owner: GIL, TATIANA ARIEL Roll Type: R
 Cycle Tag Sales Verification Other: VET APP Inspection level: 1 2 3 4 LCB TTO INSP AV: 205380
 RMV Land: 259020 RMV Imp: 107870 RMV Total: 366890 MAV: 205380 MSAV: 0 SAV: 0
 Comment:

UPD INV AND RESET MAV VET APP

Notations

No notation data available.

MLS 815635

OSDs

Count	Code	Description	RMV	Code Area	Exception
1	MKTF	OSD - FAIR	35000	92430	0

Land

Site: 1 Code Area: 92430 Size: 1.47 Acres Use Code: 005 Zone: REST SAV Use: Exception: 0
 Class: 2HD Value Source: Rural Restrictive Description: TWO HILL DRY RMV: 224020 Exception: Y N
 Adjustment(s): GSOIL Fire Patrol: Description:
 Comments: 01-02; REAPPRAISAL

Improvements - Residence / Manufactured Structures

Bldg: 1 Code Area: 92430 Stat Class: 121 Year Blt: 1920 Eff Year Blt: 1920 Sq.Ft: 1193 % Complete: 100
 Desc: One Story Only 131 - 1952 Dimensions: RMV: 89110
 Func Obsc: 100 Econ %: 100 Other %: 100 Exception: 0 Adjust: Adjust RMV: 0
 R/W/EP/IP/F/B/D

Floors

Type	Class	Display Group	Floor Size	Beds	Baths	Yr Blt	Eff Yr Blt	Inventory
First Floor	3-	2	Finished 1193 1233	2	FB-1	1920	1920	BATH - 1, KIT-, ROOF, HVAC, FP - 2 Exception: Y N

Accessories

Description	Class	Size SqFt	Eff Yr Blt	RMV	Quantity
ENCLOSED PORCH PART OF MA NOW	2	60	1920	795	1 Exception: Y N
YARD IMPROVEMENTS GOOD AVG	2	1	2000	13243	1 Exception: Y N

Improvements - Accessory Buildings

Bldg: 2 Code Area: 92430 Stat Class: 341 Year Blt: 1970 Eff Year Blt: 1970 Sq.Ft: 320 % Complete: 100
 Desc: Multi Purpose Shed (MP) Dimensions: 20x16 RMV: 1070
 Func Obsc: 100 Econ %: 100 Other %: 100 Exception: 0 Adjust: Adjust RMV: 0

Floors

Type	Class	Display Group	Floor Size	Beds	Baths	Yr Blt	Eff Yr Blt	Inventory
Multi-Purpose Bldg	4	Finished	320	0	0	1970	1970	NO VALUE Exception: Y N

Accessories

Description	Class	Size SqFt	Eff Yr Blt	RMV	Quantity
No accessory data available					

Bldg: 3 Code Area: 92430 Stat Class: 354 Year Blt: 1960 Eff Year Blt: 1960 Sq.Ft: 280 % Complete: 100
 Desc: Lean-to Light (LTL) Dimensions: 20x14 RMV: 230
 Func Obsc: 100 Econ %: 100 Other %: 100 Exception: 0 Adjust: Adjust RMV: 0

Floors

Type	Class	Display Group	Floor Size	Beds	Baths	Yr Blt	Eff Yr Blt	Inventory
Lean-to Light Duty	4	Finished	280	0	0	1960	1960	NO VALUE Exception: Y N

Accessories

Description	Class	Size SqFt	Eff Yr Blt	RMV	Quantity
No accessory data available					

Bldg: 4 Code Area: 92430 Stat Class: 351 Year Blt: 2000 Eff Year Blt: 2000 Sq.Ft: 1500 % Complete: 100
 Desc: General Purpose Building (GB) Dimensions: 30x50 RMV: 17460
 Func Obsc: 100 Econ %: 100 Other %: 100 Exception: 0 Adjust: Adjust RMV: 0

Floors

Type	Class	Display Group	Floor Size	Beds	Baths	Yr Blt	Eff Yr Blt	Inventory	Exception: Y N
General Purpose Bldg	5	Finished	1500	0	0	2000	2000	FAIR	

Accessories

Description	Class	Size SqFt	Eff Yr Blt	RMV	Quantity
No accessory data available					

[354 LTL 40X16 2000/2008](#)

[357 FC 16X10 2000/2000](#)

SKETCH/AREA TABLE ADDENDUM

SUBJECT INFO

File No.: 533711 Parcel No.: 084W24A 00300
 Property Address: 4112 Vitae Akprings Rd S
 City: Salem County: State: OR ZipCode: 97306
 Owner:
 Client: Client Address:
 Appraiser Name: Inspection Date:

SKETCH

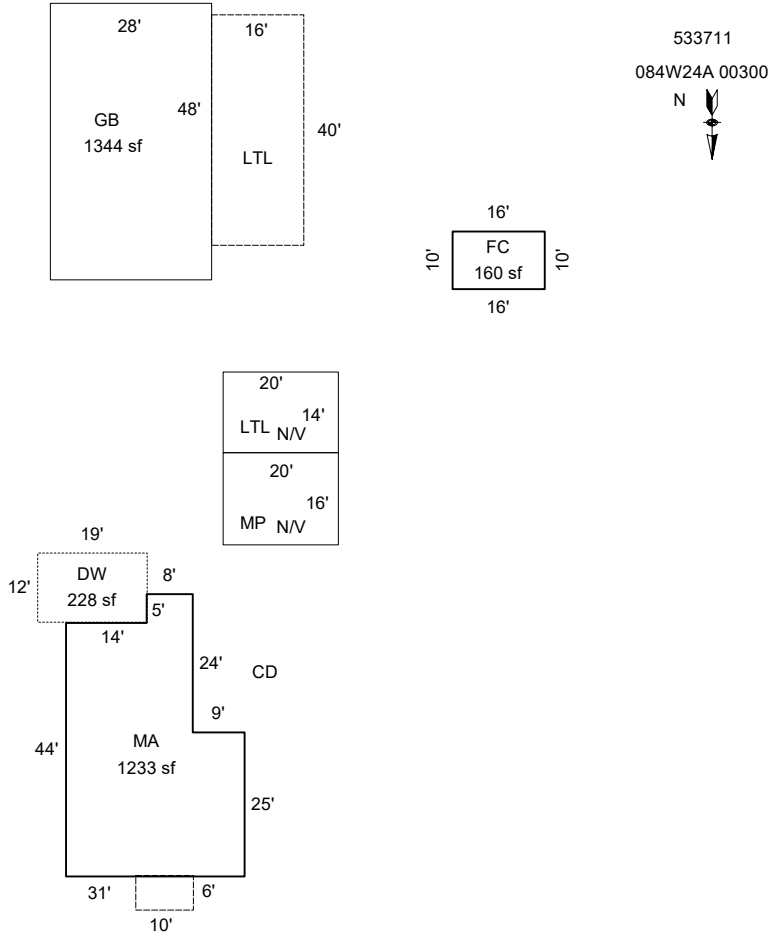

Vitae Spring Rd

Sketch by ApexSketch

AREA CALCULATIONS SUMMARY

Code	Description	Factor	Net Size	Perimeter	Net Totals
GBA1	MP	1	320	72	
	LTL	1	280	68	
	GB	1	1344	152	1944
GBA7	FC	1	160	52	160
GLA1	MA	1	1233	160	1233
P/P	Porch	1	60	32	
	LTL	1	640	112	
	DW	1	228	62	928
	Net LIVABLE	cnt	1 (rounded)		1,233
	Net BUILDING	cnt	4 (rounded)		2,104

COMMENT TABLE 1

Apex 11/01/2012 Jane
 UPD BY WW 8.13.24

COMMENT TABLE 2

WW 8.13.24

COMMENT TABLE 3

PROGRAM CHANGE L4