

Acct ID: 536587 MTL: 093W30A001300 Date: 7/24/24 Appr: JS/MDL Prop Class: 912 RMV Prop Class: 401
 Situs: 13374 MARLATT RD S JEFFERSON OR 97352 MaSaNh: 07 06 000 Unit: 23889 Year: 2024

Last Date Appraised: 08/03/2018 Appraiser: MATT LORD Retag: Y (N) Tag info: _____
 Owner: TALBOT COMMUNITY CHURCH Roll Type: R
 Cycle Tag Sales Verification Other: _____ Inspection level: 1 2 3 4 LCB TTO INSP AV: 256930
 RMV Land: 216880 RMV Imp: 1164290 RMV Total: 1381170 MAV: 256930 MSAV: 0 SAV: 0
 Comment: _____

Notations 24-25 M/S Church Project
 No notation data available.

OSDs

Count	Code	Description	RMV	Code Area	Exception
1	MKTA	OSD - AVERAGE	40000	14530	0

per BES 2 OSDA on churches

Land

Site: 1 Code Area: 14530 Size: 2.00 Acres Use Code: 004 Zone: NREST SAV Use: _____ Exception: 0
 Class: Value Source: Rural at MKT Description: RMV: 176880 Exception: Y N
 Adjustment(s): 2bdss Fire Patrol: _____ Description: _____
 Comments: 08-09: PT OF R36584 (SLIVER OF LAND) AND R36587// 03-04: REAPPRAISAL 04-05: RECALC PROJECT, LAND SCHEDULE CHANGES.

Improvements - Residence / Manufactured Structures

Bldg: 1 Code Area: 14530 Stat Class: 141 Year Blt: 1966 Eff Year Blt: 1966 Sq.Ft: 2168 % Complete: 100
 Desc: One Story Only Dimensions: RMV: 246330
 Func Obsc: 100 Econ %: 100 Other %: 100 Exception: 0 Adjust: Adjust RMV: 0

Floors

Type	Class	Display Group	Floor Size	Beds	Baths	Yr Blt	Eff Yr Blt	Inventory	Exception
First Floor	4	Finished	2168	4	FB-2	1966	1966	BATH - 2, KIT, HVAC, FP - 1, ROOF	Y N
Garage Attached	4	Unfinished	728	0	0	1966	1966	ROOF	Y N

Accessories

Description VI 4A Class Size SqFt Eff Yr Blt RMV Quantity
 No accessory data available

Bldg: 4 Code Area: 14530 Stat Class: 108 Year Blt: 1990 Eff Year Blt: 1990 Sq.Ft: 0 % Complete: 100
 Desc: Residential Other Improvements Dimensions: RMV: 12230
 Func Obsc: 100 Econ %: 100 Other %: 100 Exception: 0 Adjust: Adjust RMV: 0

Floors

Type	Class	Display Group	Floor Size	Beds	Baths	Yr Blt	Eff Yr Blt	Inventory	Exception
No floor data available									

Accessories

Description VI Class Size SqFt Eff Yr Blt RMV Quantity
 ASPHALT DRIVEWAY 1 5824 1990 12230 1 Exception: Y N

Bldg: 5 Code Area: 14530 Stat Class: 138 Year Blt: 1980 Eff Year Blt: 1980 Sq.Ft: 0 % Complete: 100
 Desc: Res other improvements Dimensions: RMV: 6720
 Func Obsc: 100 Econ %: 100 Other %: 100 Exception: 0 Adjust: Adjust RMV: 0

Floors

Type	Class	Display Group	Floor Size	Beds	Baths	Yr Blt	Eff Yr Blt	Inventory	Exception
Carport Detached	3	Unfinished	200	0	0	1980	1980	ROOF	Y N

Accessories

Description Class Size SqFt Eff Yr Blt RMV Quantity
 No accessory data available

Bldg: 6 Code Area: 14530 Stat Class: 107 Year Blt: _____ Eff Year Blt: _____ Sq.Ft: 0 % Complete: 100
 Desc: Yard Improvements Dimensions: RMV: 15750
 Func Obsc: 100 Econ %: 100 Other %: 100 Exception: 0 Adjust: Adjust RMV: 0

Floors

Type	Class	Display Group	Floor Size	Beds	Baths	Yr Blt	Eff Yr Blt	Inventory	Exception
No floor data available									

Accessories

Description	Class	Size SqFt	Eff Yr Blt	RMV	Quantity	
YARD IMPROVEMENTS AVERAGE	0	0	0	15750	1	Exception: Y N

Improvements - Accessory Buildings

Bldg: 2	Code Area: 14530	Stat Class: 901	Year Blt: 1930	Eff Year Blt: 1930	Sq.Ft: 5006	% Complete: 100
Desc: PARSONAGE			Dimensions:		RMV: 375540	
Func Obsc: 100	Econ %: 100	Other %: 100	Exception: 0	Adjust:	Adjust RMV: 0	

Floors

Type	Class	Display Group	Floor Size	Beds	Baths	Yr Blt	Eff Yr Blt	Inventory	
First Floor	4	Finished	2503	0	0	1930	1930		Exception: Y N
Basement	4	Finished	2503	0	0	0	0		Exception: Y N

Accessories

Description	Class	Size SqFt	Eff Yr Blt	RMV	Quantity
No accessory data available					

Bldg: 3	Code Area: 14530	Stat Class: 901	Year Blt: 1930	Eff Year Blt: 1930	Sq.Ft: 7336	% Complete: 100
Desc: PARSONAGE			Dimensions:		RMV: 507720	
Func Obsc: 100	Econ %: 100	Other %: 100	Exception: 0	Adjust:	Adjust RMV: 0	

Floors

Type	Class	Display Group	Floor Size	Beds	Baths	Yr Blt	Eff Yr Blt	Inventory	
First Floor	4	Finished	6556	0	0	1930	1930		Exception: Y N
Basement	4	Finished	780	0	0	0	0		Exception: Y N

Accessories

Description	Class	Size SqFt	Eff Yr Blt	RMV	Quantity
No accessory data available					

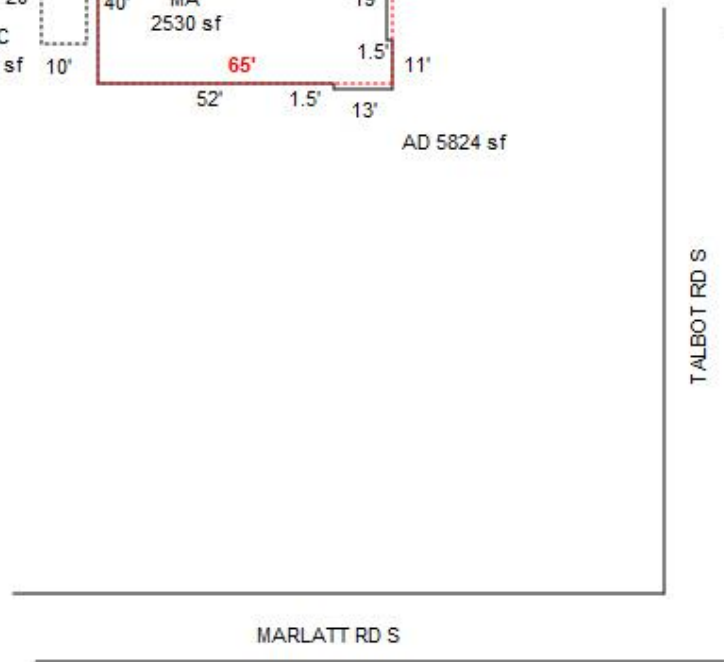
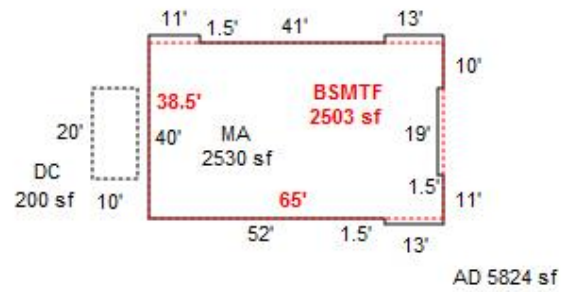
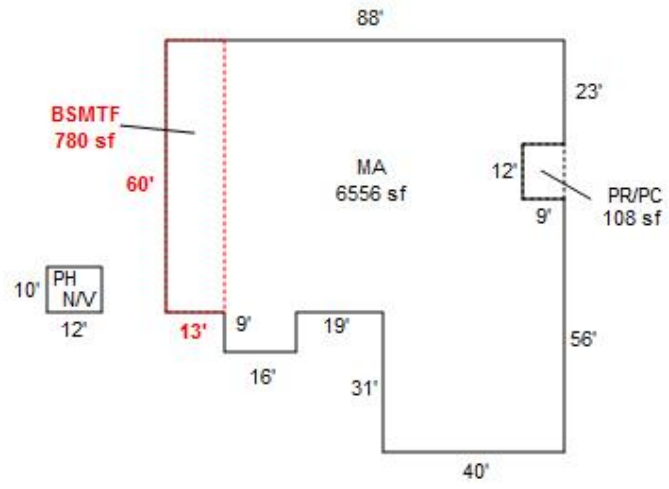
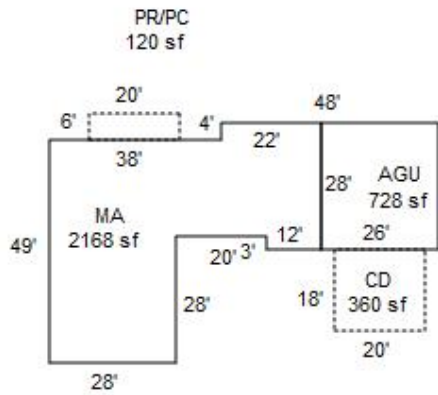



R36587
DC PH

8/3/18



R36587

MA 2530sf

8/3/18



R36587
MA 6556sf

8/3/18



R36587
MA 2168sf BACK

8/3/18



R36587
MA 2168sf

8/3/18









7/24/24