

SKETCH/AREA TABLE ADDENDUM

SUBJECT INFO

File No.: 600853 Parcel No.: 062W32CD03600
 Property Address: 5275 49TH AVE NE
 City: SALEM County: Marion State: OR ZipCode: 97305
 Owner:
 Client: Client Address:
 Appraiser Name: Inspection Date:

SKETCH

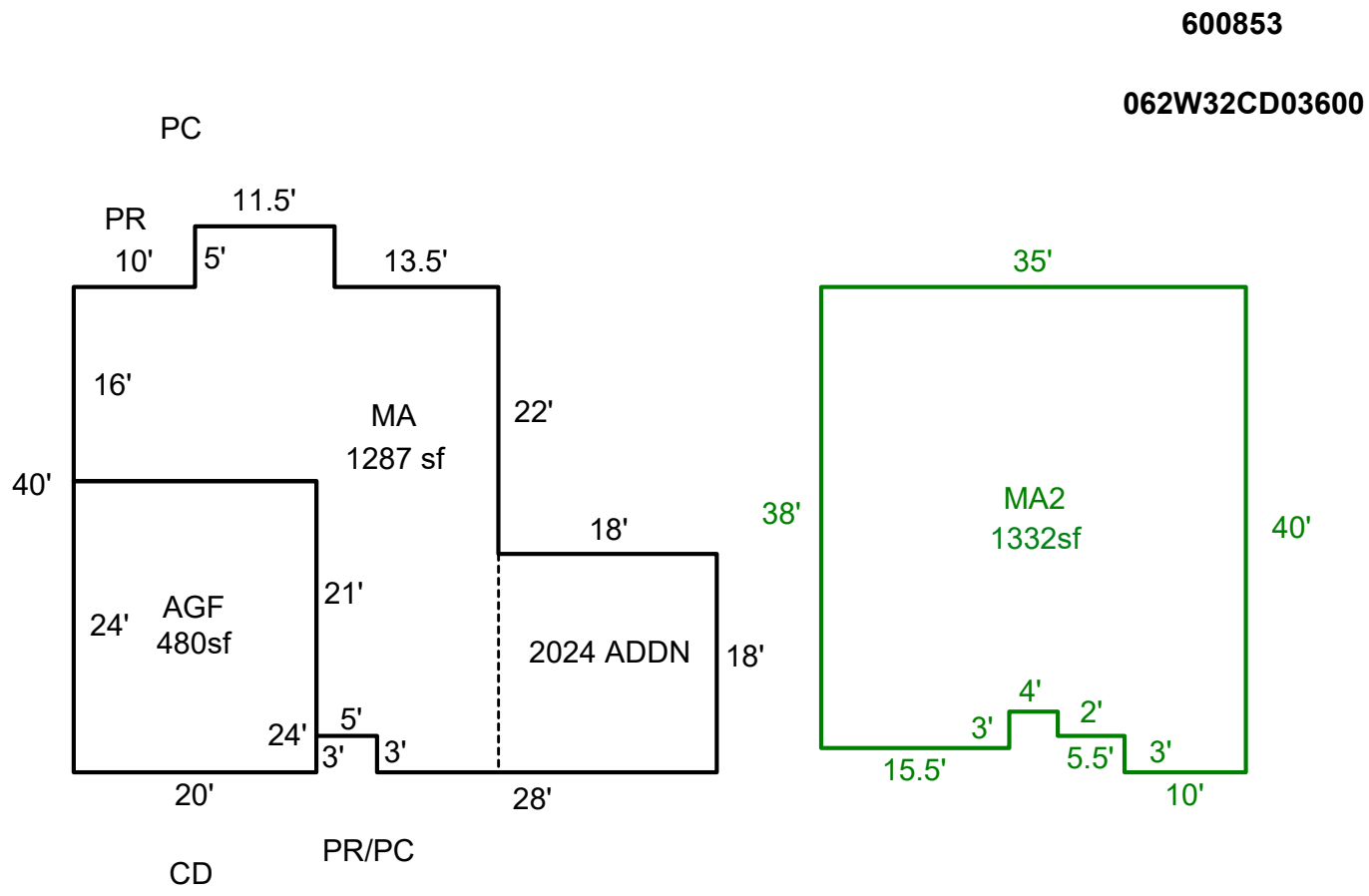

Sketch by ApexSketch

AREA CALCULATIONS SUMMARY

Code	Description	Factor	Net Size	Perimeter	Net Totals
GLA	MA	1.0	1286.5	196.0	1286.5
GLA2	MA2	1.0	1332.5	156.0	1332.5
GAR	AGF	1.0	480.0	88.0	480.0

COMMENT TABLE 1

APEX DRAWN BY CBAILEY 11/23/21
 Updated 10.24.24

COMMENT TABLE 2

COMMENT TABLE 3

Net LIVABLE cnt 2 (rounded) 2,619