

Acct ID: 528871 MTL: 081W33B001200 Date: **12-12-23** Appr: **MSL** Prop Class: **401** RMV Prop Class: **409** **401**  
 Situs: 11862 STEINKAMP RD SE AUMSVILLE OR 97325 MaSaNh: 07 06 005 Unit: 28209 Year: **2023** **2024**  
 Last Date Appraised: 05/14/2012 Appraiser: MATT LORD Retag: Y **(N)** Tag info: 2024 - NEW CONSTRUCTION (Residence)  
 Owner: DIAZ, MICHAEL J Roll Type: R  
 Cycle: **(Tag)** Sales Verification Other: Inspection level: 1 **(2)** 3 4 LCB **(ITO)** **(INSP)** AV: 179720  
 RMV Land: 196510 RMV Imp: 51530 RMV Total: 248040 MAV: 179720 MSAV: 0 SAV: 0  
 Comment: **REMOVE MANUF ADD NEW MA PULL TAG FINNED 10-9-23**

Notations **24-25: (23-001704) RPL MSH w/SFD 100% complete pull TAB**  
 No notation data available.

OSDs

Count	Code	Description	RMV	Code Area	Exception
1	MKTF	OSD - FAIR	35000	29588	0

Land **Amy 5-9-24**

Site: 1 Code Area: 29588 Size: 2.70 Acres Use Code: 004 Zone: NREST SAV Use: Exception: 0  
 Class: **2BDSS** Value Source: Rural at MKT Description: RMV: 161510 Exception: Y N  
 Adjustment(s): **GSOIL** Fire Patrol: Description:  
 Comments: 2002-03 REAPPRAISAL.

Improvements - Residence / Manufactured Structures

Bldg: 2 Code Area: 29588 Stat Class: 457 Year Blt: 1989 Eff Year Blt: 1989 Sq.Ft: 1539 % Complete: 100  
 Desc: MANUF STRUCT, CLASS 5, 26' THROUGH 28' WIDE DOUBLE Dimensions: RMV: 41200  
 Func Obsc: 100 Econ %: 100 Other %: 100 Exception: 0 Adjust: Adjust RMV: 0

**Floors**

Type	Class	Display Group	Floor Size	Beds	Baths	Yr Blt	Eff Yr Blt	Inventory	Exception
First Floor	5	Finished	1539	0	FB-2	1989	1989	SKRT+, KIT-	Y N

**Accessories**

Description	Class	Size SqFt	Eff Yr Blt	RMV	Quantity
No accessory data available					

Bldg: 3 Code Area: 29588 Stat Class: 107 Year Blt: Eff Year Blt: Sq.Ft: 0 % Complete: 100  
 Desc: Yard Improvements Dimensions: RMV: 6380  
 Func Obsc: 100 Econ %: 100 Other %: 100 Exception: 0 Adjust: Adjust RMV: 0

**Floors**

Type	Class	Display Group	Floor Size	Beds	Baths	Yr Blt	Eff Yr Blt	Inventory	Exception
No floor data available									

**Accessories**

Description	Class	Size SqFt	Eff Yr Blt	RMV	Quantity
YARD IMPROVEMENTS AVERAGE	1		0	5103	1

Improvements - Accessory Buildings

Bldg: 1 Code Area: 29588 Stat Class: 341 Year Blt: 1976 Eff Year Blt: 1976 Sq.Ft: 416 % Complete: 100  
 Desc: Multi Purpose Shed (MP) Dimensions: 26x16 RMV: 3860  
 Func Obsc: 100 Econ %: 100 Other %: 100 Exception: 0 Adjust: Adjust RMV: 0

**Floors**

Type	Class	Display Group	Floor Size	Beds	Baths	Yr Blt	Eff Yr Blt	Inventory	Exception
Multi-Purpose Bldg	6	Finished	416	0	0	1976	1976	FAIR	Y N

**Accessories**

Description	Class	Size SqFt	Eff Yr Blt	RMV	Quantity
No accessory data available					

ACCOUNT # 528871 DATE: 12-12-23 RMV CLASS \_\_\_\_\_ PROP CLASS \_\_\_\_\_  
 MTL \_\_\_\_\_ APPR GWK TAG Y N \_\_\_\_\_  
 COMMENTS: \_\_\_\_\_

RESIDENCE / MANUFACTURED STRUCTURES

ACCESSORY IMPROVEMENTS / OUTBUILDINGS

STAT 142 QLTY + - FLOOR MA  
 AREA 2004 EFF AREA 2004 BED 4  
 ROOF + HVAC +  
 BATH PKG: 2 BATH BATH + 1/2 BTH  
 FIREPLACE: \_\_\_\_\_  
 KITCHEN - + KN A16  
 YR BLT 2023 EFF YR 2023 ECON \_\_\_\_\_  
 % COMP 100 % GOOD \_\_\_\_\_ FUNC \_\_\_\_\_  
 EXCEPT Y N LUMP SUM: \_\_\_\_\_  
 MISC: \_\_\_\_\_  
 YI CLASS \_\_\_\_\_ F G A E  
 SKIRT - LIN FT \_\_\_\_\_  
 COMMENT: \_\_\_\_\_

TYPE AGP  
 STAT / CLASS 4  
 SIZE 792  
 FAIR  
AVERAGE  
 GOOD  
 EXCELLENT  
 BATH \_\_\_\_\_  
 YR BLT 2023  
 EFF YR \_\_\_\_\_  
 % COMP 100  
 EXCEPT Y N  
 MISC: \_\_\_\_\_  
 COMMENT: \_\_\_\_\_

TYPE MS  
 STAT / CLASS 5  
 SIZE 12x22  
264  
 FAIR  
 AVERAGE  
 GOOD  
 EXCELLENT  
 BATH \_\_\_\_\_  
 YR BLT 2021  
 EFF YR \_\_\_\_\_  
 % COMP \_\_\_\_\_  
 EXCEPT N  
 MISC: \_\_\_\_\_  
 COMMENT: \_\_\_\_\_

STAT 4 QLTY + - FLOOR ATT  
 AREA 458 EFF AREA 458 BED \_\_\_\_\_  
 ROOF + HVAC +  
 BATH PKG: \_\_\_\_\_ BATH BATH + 1/2 BTH  
 FIREPLACE: \_\_\_\_\_  
 KITCHEN - +  
 YR BLT 2023 EFF YR 2023 ECON \_\_\_\_\_  
 % COMP 100 % GOOD \_\_\_\_\_ FUNC \_\_\_\_\_  
 EXCEPT Y N LUMP SUM: \_\_\_\_\_  
 MISC: \_\_\_\_\_  
 YI CLASS \_\_\_\_\_ F G A E  
 SKIRT - LIN FT \_\_\_\_\_  
 COMMENT: \_\_\_\_\_

TYPE MP  
 STAT / CLASS 6  
 SIZE 14x16  
224  
 FAIR  
AVERAGE  
 GOOD  
 EXCELLENT  
 BATH \_\_\_\_\_  
 YR BLT 2021  
 EFF YR \_\_\_\_\_  
 % COMP \_\_\_\_\_  
 EXCEPT N  
 MISC: \_\_\_\_\_  
 COMMENT: \_\_\_\_\_

TYPE MP  
 STAT / CLASS 6  
 SIZE 8x14  
 FAIR  
AVERAGE  
 GOOD  
 EXCELLENT  
 BATH \_\_\_\_\_  
 YR BLT 2016  
 EFF YR \_\_\_\_\_  
 % COMP \_\_\_\_\_  
 EXCEPT Y N  
 MISC: \_\_\_\_\_  
 COMMENT: \_\_\_\_\_

STAT \_\_\_\_\_ QLTY + - FLOOR \_\_\_\_\_  
 AREA \_\_\_\_\_ EFF AREA \_\_\_\_\_ BED \_\_\_\_\_  
 ROOF + HVAC +  
 BATH PKG: \_\_\_\_\_ BATH BATH + 1/2 BTH  
 FIREPLACE: \_\_\_\_\_  
 KITCHEN - +  
 YR BLT \_\_\_\_\_ EFF YR \_\_\_\_\_ ECON \_\_\_\_\_  
 % COMP \_\_\_\_\_ % GOOD \_\_\_\_\_ FUNC \_\_\_\_\_  
 EXCEPT Y N LUMP SUM: \_\_\_\_\_  
 MISC: \_\_\_\_\_  
 YI CLASS \_\_\_\_\_ F G A E  
 SKIRT - LIN FT \_\_\_\_\_  
 COMMENT: \_\_\_\_\_

# SKETCH/AREA TABLE ADDENDUM

## SUBJECT INFO

File No.: 528871 Parcel No.: 081W33B001200  
 Property Address: 11862 STEINKAMP ROAD SE  
 City: AUMSVILLE County: MARION State: OR ZipCode: 97325  
 Owner:  
 Client Address:  
 Appraiser Name: Inspection Date:

## SKETCH

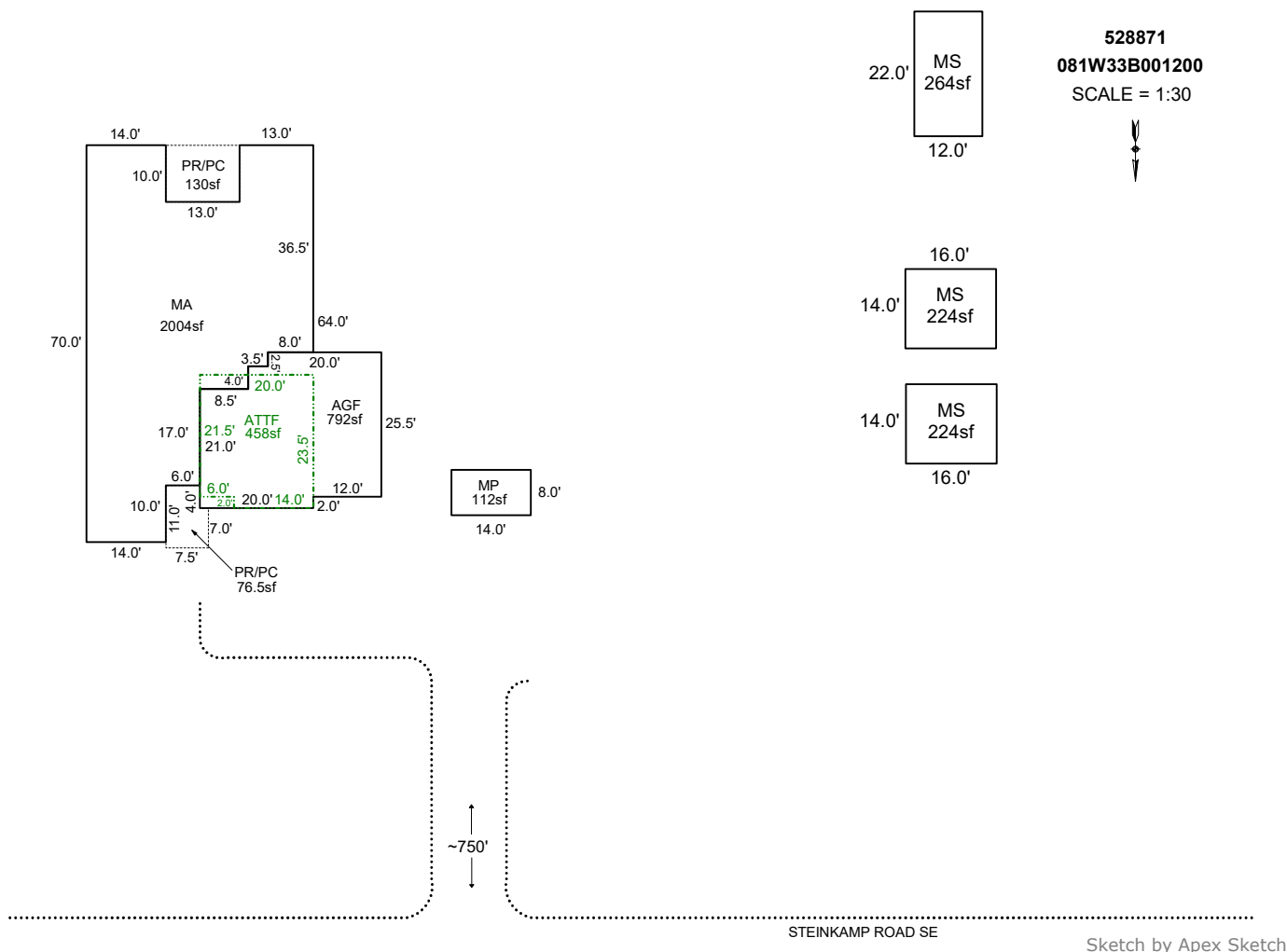

Sketch by Apex Sketch

### AREA CALCULATIONS SUMMARY

Code	Description	Factor	Net Size	Perimeter	Net Totals
GBA1	MP	1.0	112.0	44.0	
	MS	1.0	264.0	68.0	
	MS	1.0	224.0	60.0	
	MS	1.0	224.0	60.0	824.0
GLA1	MA	1.0	2004.0	240.0	2004.0
GLA2	ATTF	1.0	458.0	87.0	458.0
GAR	AGF	1.0	792.0	119.0	792.0
P/P	PR/PC	1.0	76.5	37.0	
	PR/PC	1.0	130.0	46.0	206.5
	Net LIVABLE	cnt	2 (rounded)		2,462
	Net BUILDING	cnt	4 (rounded)		824

### COMMENT TABLE 1

APEX BY CJURAN 06/05/2025 555-23-001704  
 UPDATED BY CJURAN 12/19/2023

### COMMENT TABLE 2

CL 12/12/2023

### COMMENT TABLE 3

TAGS L2



12/12/23



12/12/23



12/12/23



12/23/23



12/23/23



12/23/23



12/23/23