

Acct ID: 528900 MTL: 081W28C002300 Date: **8-29-24** Appr: **LUKE** Prop Class: 401 RMV Prop Class: 401
 Situs: 11771 STEINKAMP RD SE AUMSVILLE OR 97325 MaSaNh: 01 06 008 Unit: 28647 Year: 2024

Last Date Appraised: 03/11/2016 Appraiser: CLINT LUKE Retag: **Y** Tag info: _____

Owner: OLSON, DEREK J Roll Type: _____

Cycle Tag: **Sales Verification** Other: _____ Inspection level: 1 2 3 **4** LCB TTO INSP AV: 305100

RMV Land: 280210 RMV Imp: 319830 RMV Total: 600040 MAV: 305100 MSAV: 0 SAV: 0

Comment: **MLS 809076 DOM 184 LP 729900 EXPIRED 3/1/24 @ 699,900**

MLS 814307 DOM 60 LP 699,900 SP 715,000

No notation data available.

OSDs

Count	Code	Description	RMV	Code Area	Exception
1	MKTA	OSD - AVERAGE	45000	29588	0

Land

Site: 1 Code Area: 29588 Size: 2.23 Acres Use Code: 004 Zone: NREST SAV Use: _____ Exception: 0
 Class: Value Source: Rural at MKT Description: _____ RMV: 235210 Exception: Y N
 Adjustment(s): **1.34 2BSS .89 4BDSS** File Patrol: _____ Description: _____
 Comments: 2960180 HV=2 /00-01; SEPERATE THE HOMESITE FROM THE INCREMENT /02-03: DISQ 1.23 AC FROM F/U 03-04/ALN: HARDSHIP MH, COND. USE NO.02-64 **GSON**

Improvements - Residence / Manufactured Structures

Bldg: 1 Code Area: 29588 Stat Class: 142 Year Blt: 1915 Eff Year Blt: 1950 Sq.Ft: 2772 % Complete: 100
 Desc: Multi Story above grade Dimensions: _____ RMV: 315410
 Func Obsc: 100 Econ %: 100 Other %: 100 Exception: 0 Adjust: Adjust RMV: 0

Floors

Type	Class	Display Group	Floor Size	Beds	Baths	Yr Blt	Eff Yr Blt	Inventory	Exception: Y N
First Floor	4	Finished	1680	1	FB-1	1915	1950	BATH - 1, KIT+, ROOF, HVAC, FP - 1	Y N
Second Floor	4	Finished	1092	4	FB-1	1915	1950	BATH - 1, HVAC	Y N

Accessories

Description	Class	Size SqFt	Eff Yr Blt	RMV	Quantity	Exception: Y N
YARD IMPROVEMENTS GOOD	4	1	1950	24924	1	Y N

Improvements - Accessory Buildings

Bldg: 2 Code Area: 29588 Stat Class: 341 Year Blt: 1973 Eff Year Blt: 1973 Sq.Ft: 204 % Complete: 100
 Desc: Multi Purpose Shed (MP) Dimensions: 17x12 RMV: 1070
 Func Obsc: 100 Econ %: 100 Other %: 100 Exception: 0 Adjust: Adjust RMV: 0

Floors

Type	Class	Display Group	Floor Size	Beds	Baths	Yr Blt	Eff Yr Blt	Inventory	Exception: Y N
Multi-Purpose Bldg	5	Finished	204	0	0	1973	1999	FAIR	Y N

Accessories

Description	Class	Size SqFt	Eff Yr Blt	RMV	Quantity
No accessory data available					

Bldg: 3 Code Area: 29588 Stat Class: 351 Year Blt: 1976 Eff Year Blt: 1976 Sq.Ft: 728 % Complete: 100
 Desc: General Purpose Building (GB) Dimensions: 28x26 RMV: 3350
 Func Obsc: 100 Econ %: 100 Other %: 100 Exception: 0 Adjust: Adjust RMV: 0

Floors

Type	Class	Display Group	Floor Size	Beds	Baths	Yr Blt	Eff Yr Blt	Inventory	Exception: Y N
General Purpose Bldg	5	Finished	728	0	0	1976	1976	FAIR	Y N

Accessories

Description	Class	Size SqFt	Eff Yr Blt	RMV	Quantity
No accessory data available					

HC 5 20x35 50% 1/0

INPUT
10-19-24
30
COVERED 9-3-24
LUKE

CONV
COMPLETED
10/24/24
LUKE

AV
AV

NC

50%

50%

1999

SKETCH/AREA TABLE ADDENDUM

SUBJECT INFO

File No.: 528900	Parcel No.: 081W28C 02300
Property Address: 11771 STEINKAMP RD SE	
City: Aumsville	County: Marion
State: OR	ZipCode: 97325
Owner:	
Client Address:	
Appraiser Name:	
Inspection Date:	

SKETCH

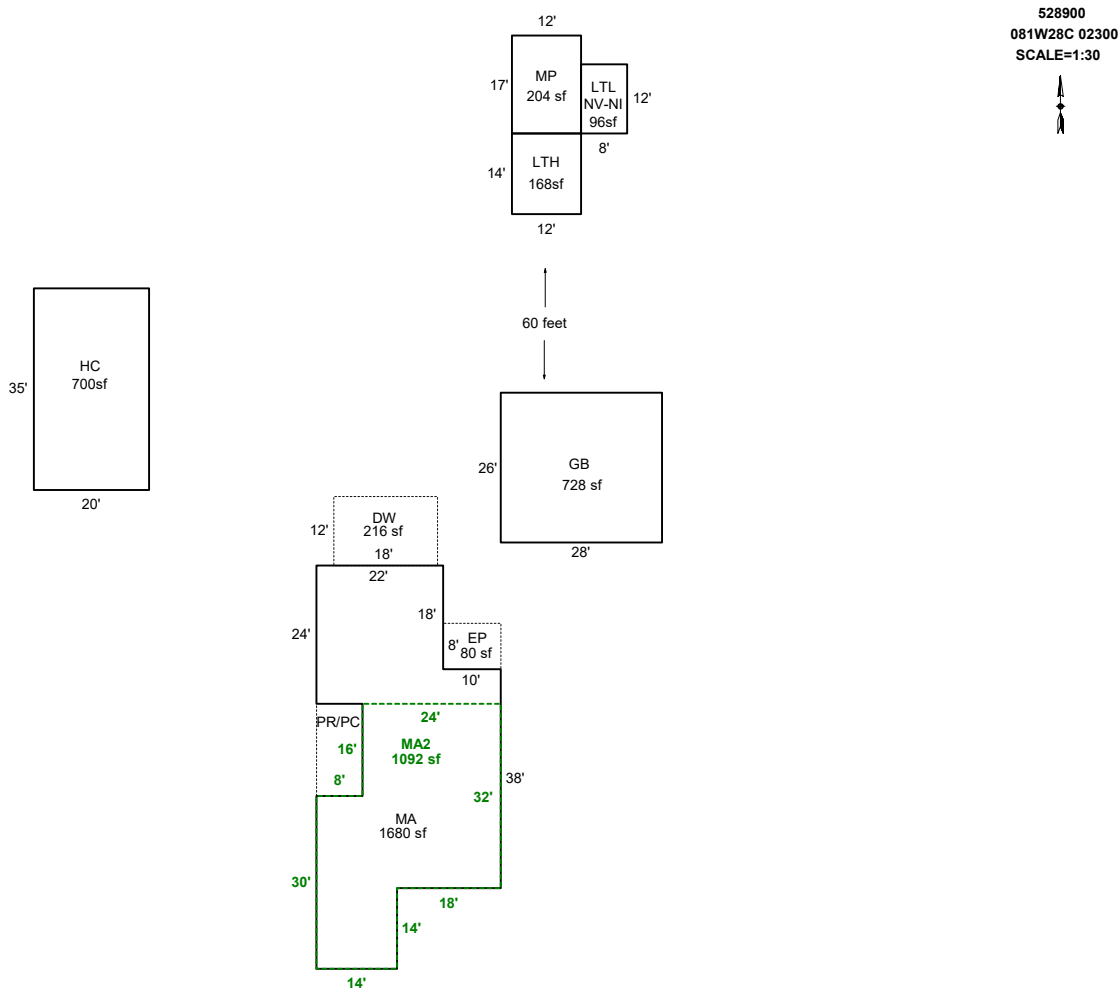

AREA CALCULATIONS SUMMARY

Code	Description	Factor	Net Size	Perimeter	Net Totals
GBA1	MP	1.0	204.0	58.0	
	GB	1.0	728.0	108.0	
	HC	1.0	700.0	110.0	
	LTH	1.0	168.0	52.0	
	LTL	1.0	96.0	40.0	1896.0
GLA1	MA	1.0	1680.0	220.0	1680.0
GLA2	MA2	1.0	1092.0	156.0	1092.0
P/P	EP	1.0	80.0	36.0	
	DW	1.0	216.0	60.0	296.0
	Net LIVABLE	cnt	2 (rounded)		2,772
	Net BUILDING	cnt	5 (rounded)		1,896

COMMENT TABLE 1

DRAWN BY JRONDEMA 3/15/16
UPDATED BY CLOBERG 10/25/24

COMMENT TABLE 2

CLUKE 08/29/24

COMMENT TABLE 3

SV L4