

Acct ID: 534915 MTL: 091W18D000900 Date: 1/9/24 Appr: MDL Prop Class: 551 RMV Prop Class: 451
 Situs: 10107 STAYTON RD SE AUMSVILLE OR 97325 MaSaNh: 07 06 000 Unit: 75008 Year: 2024

Last Date Appraised: 01/10/2023 Appraiser: MATT LORD Retag: Y (N) Tag info: 2024 - Tags/Permit (Completion)

Owner: FULTZ, RANDALL Roll Type: R

Cycle (Tag) Sales Verification Other: Inspection level: 1 0 3 4 (LCF) TTO INSP AV: 185715

RMV Land: 159290 RMV Imp: 217670 RMV Total: 376960 MAV: 176200 MSAV: 9515 SAV: 27175

Comment: 23-24: L2 1.10.23 MDL New SFD 100% complete pull TAG

Notations 22-005446

RP/MS	Code	Description
RP	ZONED	FARM EFU ZONED

OSDs

Count	Code	Description	RMV	Code Area	Exception
1	MKTF	OSD - FAIR	35000	05545	0

Land

Site: 2 Code Area: 05545 Size: 1.00 Acres Use Code: 005 Zone: REST SAV Use: Exception: 0
 Class: 4BDS Value Source: Market Homesite Description: FOUR BENCH DRY SPECIAL SOUTH RMV: 12860 Exception: Y N

Adjustment(s): GSOIL, IRR Fire Patrol: Description:

Comments: 01-02: REVALUE BASED ON NEW PT, 00550040 /02-03: RES IS A RENTAL

Site: 3 Code Area: 05545 Size: 2.18 Acres Use Code: 005 Zone: REST SAV Use: 011 Exception: 0
 Class: 2BISS Value Source: Farm Use - EFU Description: TWO BENCH IRR SOUTH SPECIAL RMV: 32250 Exception: Y N

Adjustment(s): GSOIL, IRR Fire Patrol: Description:

Comments: Liability year - 1984 / 00550040

Site: 4 Code Area: 05545 Size: 3.00 Acres Use Code: 005 Zone: REST SAV Use: 011 Exception: 0
 Class: 4BISS Value Source: Farm Use - EFU Description: FOUR BENCH IRR SPECIAL SOUTH RMV: 40520 Exception: Y N

Adjustment(s): GSOIL, IRR Fire Patrol: Description:

Comments: Liability year - 1984 / 00550040 .01-02: SOIL CONSOLIDATION OF 3BENCH INTO 4BENCH

Site: 5 Code Area: 05545 Size: 1.06 Acres Use Code: 005 Zone: REST SAV Use: 011 Exception: 0
 Class: 2BDS Value Source: Farm Use - EFU Description: TWO BENCH DRY SOUTH SPECIAL RMV: 14990 Exception: Y N

Adjustment(s): GSOIL, IRR Fire Patrol: Description:

Comments: Liability year - 1984 / 00550040

Site: 6 Code Area: 05545 Size: 1.84 Acres Use Code: 005 Zone: REST SAV Use: 011 Exception: 0
 Class: 4BDS Value Source: Farm Use - EFU Description: FOUR BENCH DRY SPECIAL SOUTH RMV: 23670 Exception: Y N

Adjustment(s): GSOIL, IRR Fire Patrol: Description:

Comments: Liability year - 1984 / 00550040 .01-02: SOIL CONSOLIDATION OF 3BENCH INTO 4BENCH

Improvements - Residence / Manufactured Structures

Bldg: 1 Code Area: 05545 Stat Class: 121 Year Blt: 1939 Eff Year Blt: 1948 Sq.Ft: 1232 % Complete: 100

Desc: One Story Only Dimensions: RMV: 72990

Func Obsc: 100 Econ %: 100 Other %: 100 Exception: 0 Adjust: Adjust RMV: 0

Floors

Type	Class	Display Group	Floor Size	Beds	Baths	Yr Blt	Eff Yr Blt	Inventory	Exception:
First Floor	2	Finished	1232	2	FB-1	1939	1948	HVAC, ROOF, KIT+, BATH - 1	Y N

Accessories

Description	Class	Size SqFt	Eff Yr Blt	RMV	Quantity
No accessory data available					

Bldg: 5 Code Area: 05545 Stat Class: 142 Year Blt: 2022 Eff Year Blt: 2022 Sq.Ft: 2212 % Complete: 30

Desc: Multi Story above grade Dimensions: RMV: 136140

Func Obsc: 100 Econ %: 100 Other %: 100 Exception: 0 Adjust: Adjust RMV: 0

Floors

Type	Class	Display Group	Floor Size	Beds	Baths	Yr Blt	Eff Yr Blt	Inventory	Exception:
First Floor	4	Finished	1679	1	FB-1/ HB-1	2022	2022	BTH - 1, BATH - 1, ROOF, KIT, FP, HVAC+	Y N
Second Floor	4	Finished	533	2	FB-1	2022	2022	HVAC, BATH - 1	Y N
Attic	4	Unfinished	168	0	0	2022	2022		Y N
Garage Attached	4	Finished	1289	0	0	2022	2022	ROOF	Y N

Accessories

Description	Class	Size SqFt	Eff Yr Blt	RMV	Quantity	Exception: Y N
YARD IMPROVEMENTS AVERAGE	4	0	2022	8370	1	Exception: Y N

Improvements - Accessory Buildings

Bldg: 2 Code Area: 05545 Stat Class: 351 Year Blt: 1986 Eff Year Blt: 1986 Sq.Ft: 1080 % Complete: 100
Desc: General Purpose Building (GB) Dimensions: 36x30 RMV: 4290
Func Obsc: 100 Econ %: 100 Other %: 100 Exception: 0 Adjust: Adjust RMV: 0

Floors

Type	Class	Display Group	Floor Size	Beds	Baths	Yr Blt	Eff Yr Blt	Inventory	Exception: Y N
General Purpose Bldg	4	Finished	1080	0	0	1986	1986	FAIR	Exception: Y N

Accessories

Description	Class	Size SqFt	Eff Yr Blt	RMV	Quantity
No accessory data available					

Bldg: 3 Code Area: 05545 Stat Class: 354 Year Blt: 1986 Eff Year Blt: 1986 Sq.Ft: 468 % Complete: 100
Desc: Lean-to Light (LTL) Dimensions: 36x13 RMV: 490
Func Obsc: 100 Econ %: 100 Other %: 100 Exception: 0 Adjust: Adjust RMV: 0

Floors

Type	Class	Display Group	Floor Size	Beds	Baths	Yr Blt	Eff Yr Blt	Inventory	Exception: Y N
Lean-to Light Duty	4	Finished	468	0	0	1986	1986		Exception: Y N

Accessories

Description	Class	Size SqFt	Eff Yr Blt	RMV	Quantity
No accessory data available					

Bldg: 4 Code Area: 05545 Stat Class: 341 Year Blt: Eff Year Blt: Sq.Ft: 192 % Complete: 100
Desc: Multi Purpose Shed (MP) Dimensions: 16x12 RMV: 3760
Func Obsc: 100 Econ %: 100 Other %: 100 Exception: 0 Adjust: Adjust RMV: 0

Floors

Type	Class	Display Group	Floor Size	Beds	Baths	Yr Blt	Eff Yr Blt	Inventory	Exception: Y N
Multi-Purpose Bldg	4	Finished	192	0	0	0	0		Exception: Y N

Accessories

Description	Class	Size SqFt	Eff Yr Blt	RMV	Quantity
No accessory data available					

SKETCH/AREA TABLE ADDENDUM

SUBJECT INFO

File No.: 534915 Parcel No.: 091W18D 00900
 Property Address: 10107 STAYTON ROAD SE
 City: AUMSVILLE County: State: OR ZipCode: 97325
 Owner:
 Client: Client Address:
 Appraiser Name: Inspection Date:

SKETCH

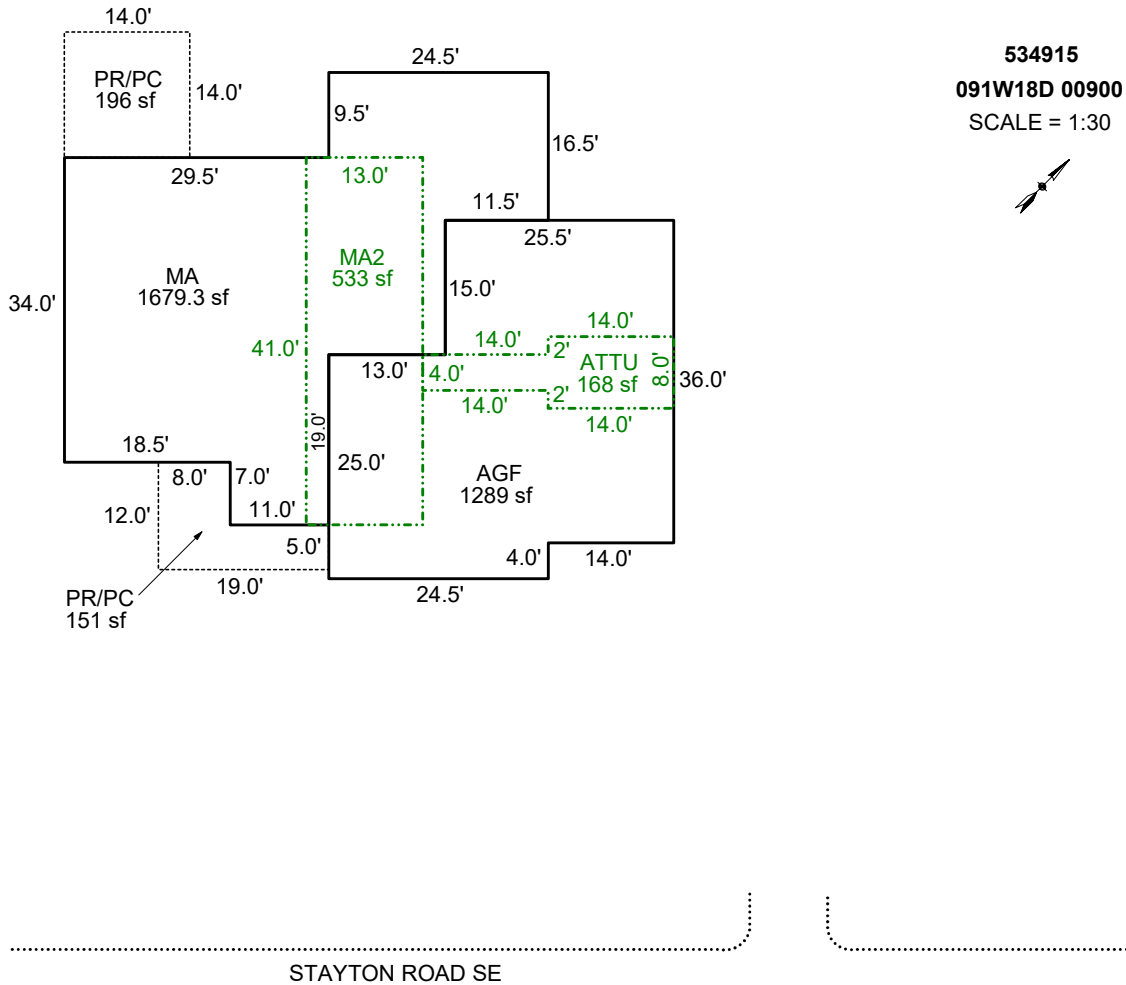

AREA CALCULATIONS SUMMARY

Code	Description	Factor	Net Size	Perimeter	Net Totals
GLA1	MA	1.0	1679.3	209.0	1679.3
GLA2	MA2	1.0	533.0	108.0	
	ATTU	1.0	168.0	72.0	701.0
GAR	AGF	1.0	1289.0	157.0	1289.0
P/P	PR/PC	1.0	151.0	62.0	
	PR/PC	1.0	196.0	56.0	347.0
Net LIVABLE		cnt	3 (rounded)		2,380

COMMENT TABLE 1

UPDATED BY CJURAN 10/10/2022 555-22-005446
 UPDATED BY CJURAN 03/05/2024

COMMENT TABLE 2

MDL 09/09/2024

COMMENT TABLE 3

TAGS L2

R34915
091W 18D 00900

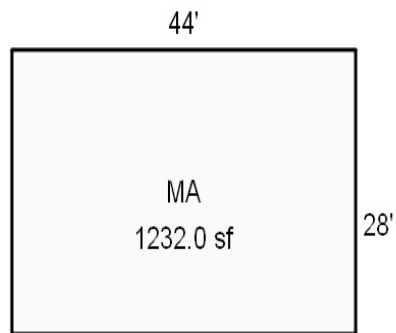
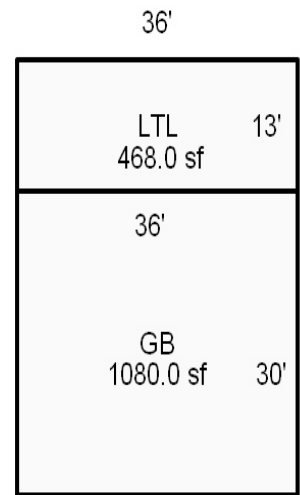

SKETCH/AREA TABLE ADDENDUM

SUBJECT INFO

File No.: 534915 Parcel No.: 091W18D 00900
 Property Address: 10107 STAYTON ROAD SE
 City: AUMSVILLE County: State: OR ZipCode: 97325
 Owner:
 Client: Client Address:
 Appraiser Name: Inspection Date:

SKETCH

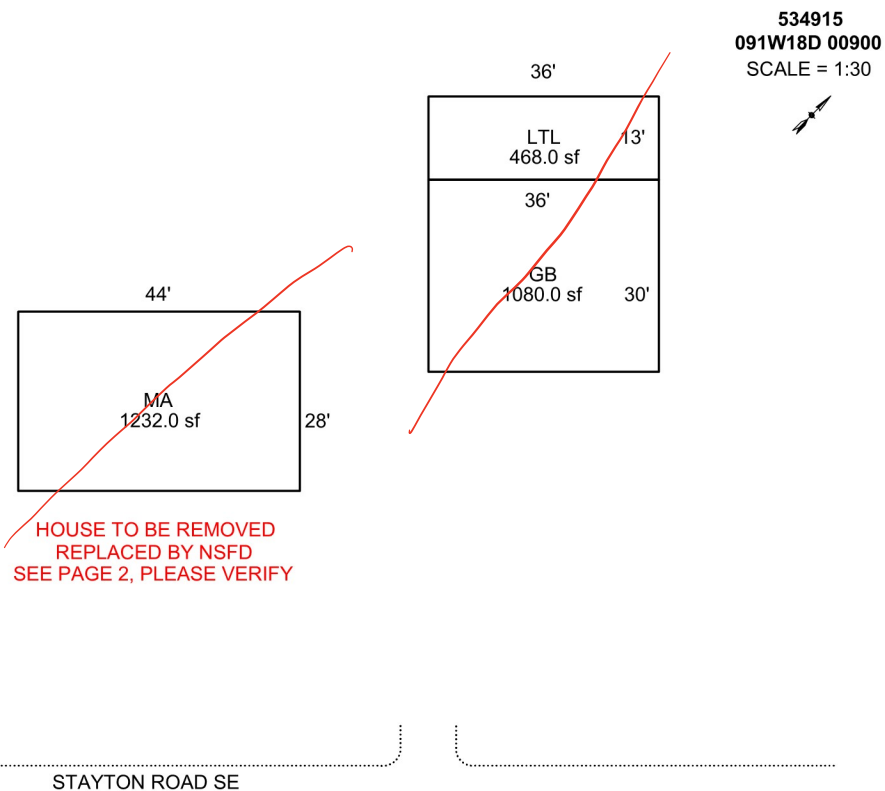

Sketch by Apex Sketch

AREA CALCULATIONS SUMMARY						COMMENT TABLE 1	
Code	Description	Factor	Net Size	Perimeter	Net Totals	UPDATED BY CJURAN 10/10/2022 555-22-005446	
GBA1	GB	1.0	1080.0	132.0			
	LTL	1.0	468.0	98.0	1548.0		
GLA1	MA	1.0	1232.0	144.0	1232.0		
						COMMENT TABLE 2	COMMENT TABLE 3
		Net LIVABLE	cnt	1 (rounded)	1,232		
		Net BUILDING	cnt	2 (rounded)	1,548		

SKETCH/AREA TABLE ADDENDUM

SUBJECT INFO

File No.: 534915 Parcel No.: 091W18D 00900
 Property Address: 10107 STAYTON ROAD SE
 City: AUMSVILLE County: State: OR ZipCode: 97325
 Owner:
 Client Address:
 Appraiser Name: Inspection Date:

SKETCH

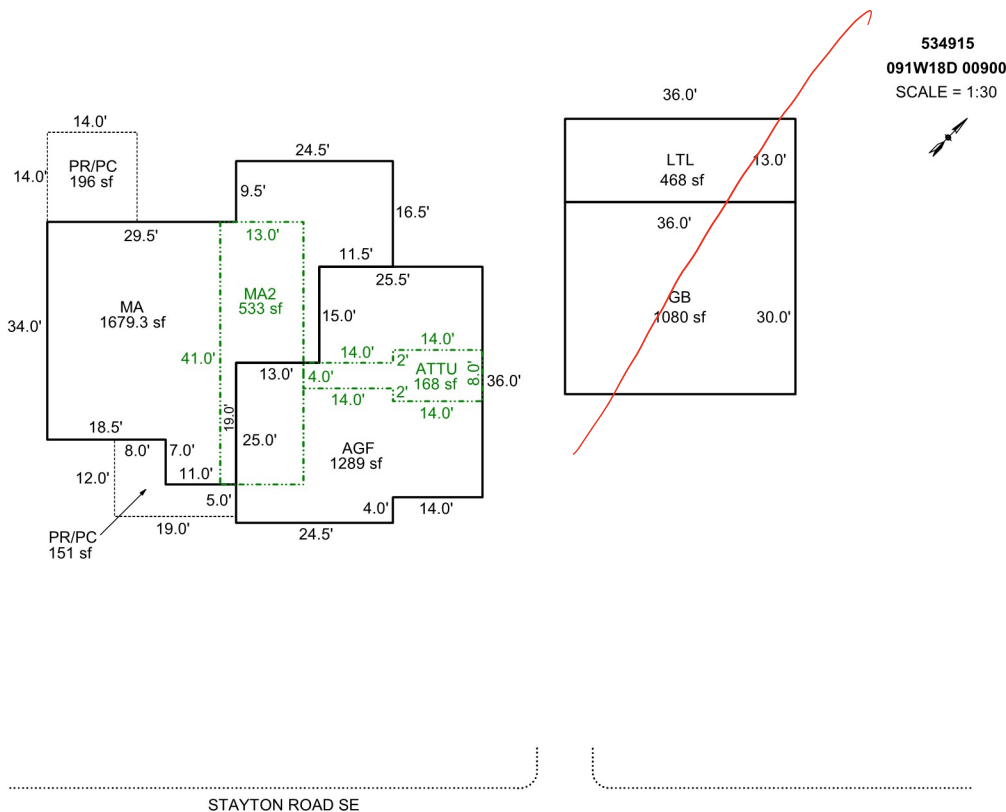

Sketch by Apex Sketch

AREA CALCULATIONS SUMMARY

Code	Description	Factor	Net Size	Perimeter	Net Totals
GBA1	LTL	1.0	468.0	98.0	
	GB	1.0	1080.0	132.0	1548.0
GLA1	MA	1.0	1679.3	209.0	1679.3
GLA2	MA2	1.0	533.0	108.0	
	ATTU	1.0	168.0	72.0	701.0
GAR	AGF	1.0	1289.0	157.0	1289.0
P/P	PR/PC	1.0	151.0	62.0	
	PR/PC	1.0	196.0	56.0	347.0
	Net LIVABLE	cnt	3 (rounded)		2,380
	Net BUILDING	cnt	2 (rounded)		1,548

COMMENT TABLE 1

UPDATED BY CJURAN 10/10/2022 555-22-005446

COMMENT TABLE 2

L2 1/9/24 MML

COMMENT TABLE 3

TAGS



10 07



1/9/24