

Acct ID: 535058 MTL: 092W030000400 Date: 11/15/23 Appr: MOL Prop Class: 451 RMV Prop Class: 451
 Situs: 9332 70TH AVE SE TURNER OR 97392 MaSaNh: 07 06 000 Unit: 34468 Year: 2023
 Last Date Appraised: 12/21/2022 Appraiser: MATT LORD Retag: Y N Tag info: 2024 - Tags/Permit (Outbuilding)
 Owner: SCHMALZ, TROY WILLIAM Roll Type: R
 Cycle Tag Sales Verification Other: Accla Inspection level: 1 2 3 4 LCB TTO INSP AV: 198300
 RMV Land: 212070 RMV Imp: 167860 RMV Total: 379930 MAV: 198300 MSAV: 0 SAV: 0
 Comment: 23-24: L3 12.21.22 MDL
 22-23: L2 12/07/2021 CL // LEVEL 2 7.22.21 CL10

NO start 9/1/23

Notations 24-25: New GB 21-003554 60x60 steel / Expired Pull TAB

No notation data available.

OSDs

Count	Code	Description	RMV	Code Area	Exception
1	MKTA	OSD - AVERAGE	45000	05595	0

Land

Site: 2	Code Area: 05595	Size: 1.00 Acres	Use Code: 004	Zone: REST	SAV Use:	Exception: 0
Class: 4BD	Value Source: Rural Restrictive	Description: FOUR BENCH DRY	RMV: 55690	Exception: Y N		
Adjustment(s):	Fire Patrol:	Description:				
Comments: 22-23: Disq farm use						
Site: 3	Code Area: 05595	Size: 2.00 Acres	Use Code: 004	Zone: REST	SAV Use:	Exception: 0
Class: 4BD	Value Source: Rural Restrictive	Description: FOUR BENCH DRY	RMV: 111380	Exception: Y N		
Adjustment(s):	Fire Patrol:	Description:				
Comments: 550190/01-02: COMBINED LAND SEGGS - SAME SOIL CLASS, SAME LIAB YR, 2.0 TTL ACRES						

Improvements - Residence / Manufactured Structures

Bldg: 1	Code Area: 05595	Stat Class: 122 +	Year Blt: 1901	Eff Year Blt: 1930	Sq.Ft: 2160	% Complete: 100
Desc: Multi Story above grade	Dimensions:	RMV: 151470				
Func Obsc: 100	Econ %: 100	Other %: 100	Exception: 0	Adjust:	Adjust RMV: 0	

Floors

Type	Class	Display Group	Floor Size	Beds	Baths	Yr Blt	Eff Yr Blt	Inventory	Exception
First Floor	2 +	Finished	1264	0	FB-2	1901	1930	HVAC, KIT-, BATH - 2, ROOF	Y N
Second Floor	2 +	Finished	896	4	FB-1	1901	1930	HVAC, BATH - 1	Y N

Accessories

Description	Class	Size SqFt	Eff Yr Blt	RMV	Quantity
YARD IMPROVEMENTS FAIR	2	0	1930	2230	1
Exception: Y N					

Improvements - Accessory Buildings

Bldg: 2	Code Area: 05595	Stat Class: 341	Year Blt: 1995	Eff Year Blt: 1995	Sq.Ft: 272	% Complete: 100
Desc: Multi Purpose Shed (MP)	Dimensions:	RMV: 6280				
Func Obsc: 100	Econ %: 100	Other %: 100	Exception: 0	Adjust:	Adjust RMV: 0	

Floors

Type	Class	Display Group	Floor Size	Beds	Baths	Yr Blt	Eff Yr Blt	Inventory	Exception
Multi-Purpose Bldg	6	Finished	272	0	0	1995	1995	FAIR	Y N

Accessories

Description	Class	Size SqFt	Eff Yr Blt	RMV	Quantity
No accessory data available					

Bldg: 3	Code Area: 05595	Stat Class: 351	Year Blt: 1980	Eff Year Blt: 1980	Sq.Ft: 720	% Complete: 100
Desc: General Purpose Building (GB)	Dimensions: 30x24	RMV: 2440				
Func Obsc: 100	Econ %: 100	Other %: 100	Exception: 0	Adjust:	Adjust RMV: 0	

Floors

Type	Class	Display Group	Floor Size	Beds	Baths	Yr Blt	Eff Yr Blt	Inventory	Exception
General Purpose Bldg	4	Finished	720	0	0	1980	1980		Y N

Accessories

Description	Class	Size SqFt	Eff Yr Blt	RMV	Quantity
No accessory data available					

Bldg: 4	Code Area: 05595	Stat Class: 353	Year Blt: 1980	Eff Year Blt: 1980	Sq.Ft: 256	% Complete: 100
---------	------------------	-----------------	----------------	--------------------	------------	-----------------

Desc: Machine Shed (MS)

Dimensions: 16x16

RMV: 1120

Func Obsc: 100

Econ %: 100

Other %: 100

Exception: 0

Adjust:

Adjust RMV: 0

Floors

Type	Class	Display Group	Floor Size	Beds	Baths	Yr Blt	Eff Yr Blt	Inventory	Exception: Y N
Machine Shed	5	Finished	256	0	0	1980	1980		Exception: Y N

Accessories

Description	Class	Size SqFt	Eff Yr Blt	RMV	Quantity
No accessory data available					

Bldg: 5 Code Area: 05595 Stat Class: 301 Year Blt: 2001 Eff Year Blt: 2001 Sq.Ft: 90 % Complete: 100
 Desc: Accessory Improvements & Misc. Dimensions: 9x10 RMV: 0
 Func Obsc: 0 Econ %: 100 Other %: 100 Exception: 0 Adjust: Adjust RMV: 0

Floors

Type	Class	Display Group	Floor Size	Beds	Baths	Yr Blt	Eff Yr Blt	Inventory	Exception: Y N
Pump House	0	Finished	90	0	0	2001	2001		Exception: Y N

Accessories

Description	Class	Size SqFt	Eff Yr Blt	RMV	Quantity
No accessory data available					

Bldg: 6 Code Area: 05595 Stat Class: 341 Year Blt: 2001 Eff Year Blt: 2001 Sq.Ft: 400 % Complete: 100
 Desc: Multi Purpose Shed (MP) Dimensions: 20x20 RMV: 6550
 Func Obsc: 100 Econ %: 100 Other %: 100 Exception: 0 Adjust: Adjust RMV: 0

Floors

Type	Class	Display Group	Floor Size	Beds	Baths	Yr Blt	Eff Yr Blt	Inventory	Exception: Y N
Multi-Purpose Bldg	5	Finished	400	0	0	2001	2001	FAIR	Exception: Y N

Accessories

Description	Class	Size SqFt	Eff Yr Blt	RMV	Quantity
No accessory data available					

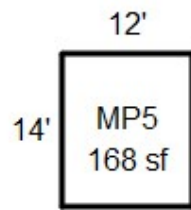

R35058
092W03 00400
1=25'

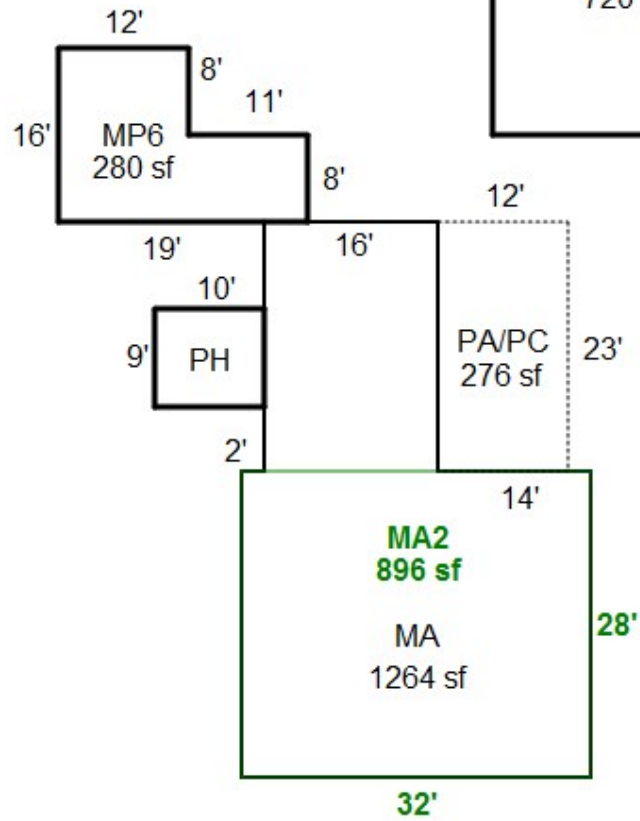
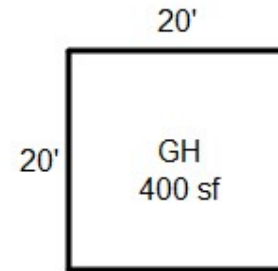
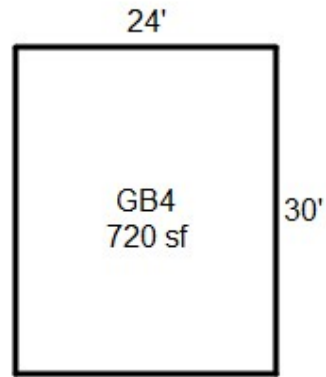

SKETCH/AREA TABLE ADDENDUM

SUBJECT INFO

File No.: 535058 Parcel No.: 092W03 00400
 Property Address: 9332 70th Av SE
 City: Turner County: State: OR ZipCode: 97392
 Owner:
 Client: Client Address:
 Appraiser Name: Inspection Date:

SKETCH

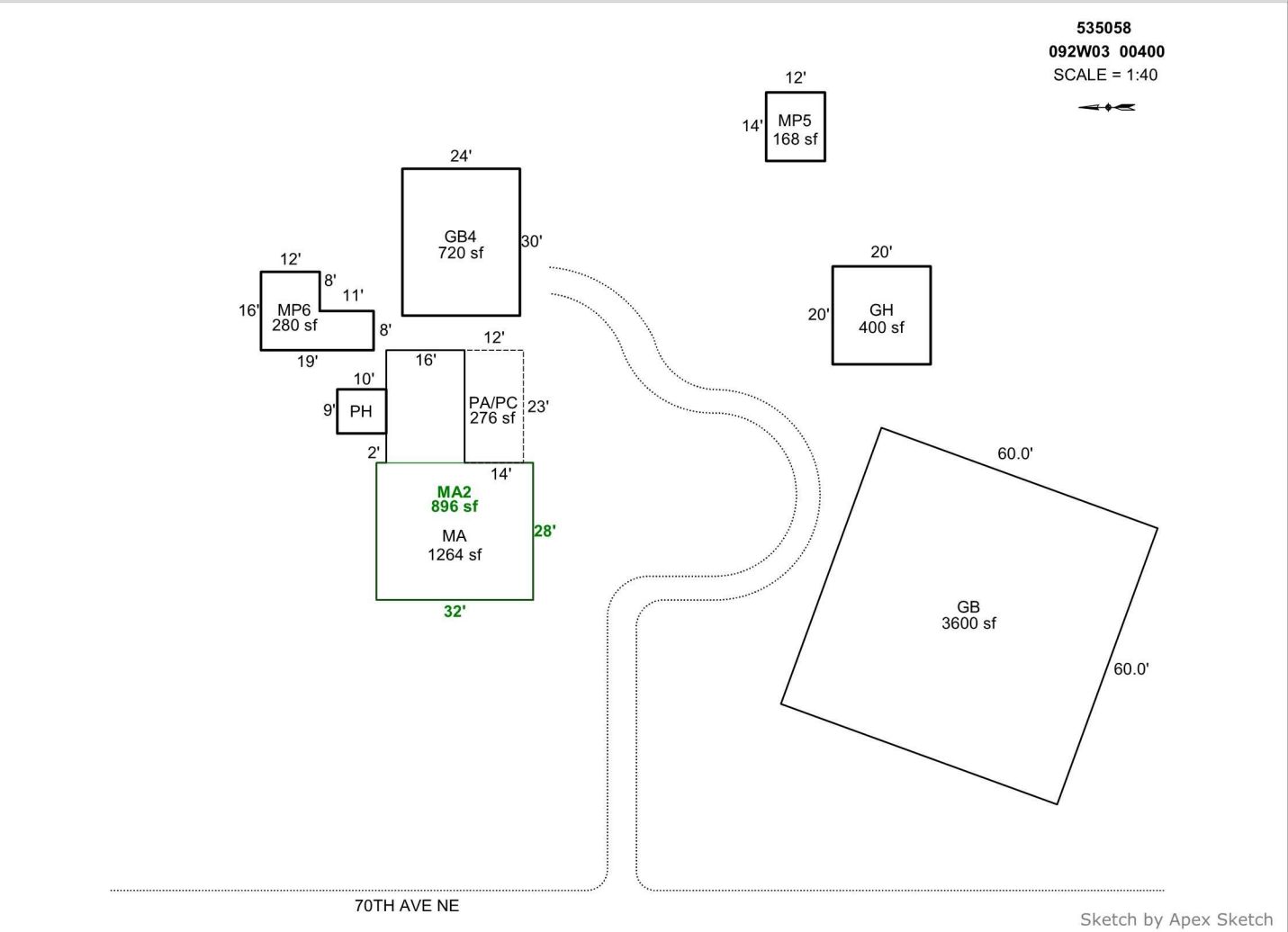

AREA CALCULATIONS SUMMARY

Code	Description	Factor	Net Size	Perimeter	Net Totals
GBA1	MP6	1.0	280.0	78.0	
	GB4	1.0	720.0	108.0	
	MP5	1.0	168.0	52.0	
	PH	1.0	90.0	38.0	
	GH	1.0	400.0	80.0	
	GB	1.0	3600.0	240.0	5258.0
GLA1	MA	1.0	1264.0	166.0	1264.0
GLA2	MA2	1.0	896.0	120.0	896.0
P/P	PA/PC	1.0	276.0	70.0	276.0
	Net LIVABLE	cnt	2 (rounded)		2,160
	Net BUILDING	cnt	6 (rounded)		5,258

COMMENT TABLE 1

Apex by RW 06/23/08
 UPDATED BY CJURAN 10/21/2021 555-21-003554

COMMENT TABLE 2

COMMENT TABLE 3