

Acct ID: 536470 MTL: 093W240001100 Date: 10/15/23 Appr: MDL Prop Class: 551 RMV Prop Class: 551
 Situs: 2947 WINTERCREEK RD SE JEFFERSON OR 97352 MaSaNh: 07 06 000 Unit: 68598 Year: 2023

Last Date Appraised: 04/11/2023 Appraiser: MATT LORD Retag: Y N Tag info:
 Owner: LEHOULLIER FAM LT & Roll Type: R
 Cycle Tag Sales Verification Other: _____ Inspection level: 1 2 3 4 LCB TTO INSP AV: 745302
 RMV Land: 396540 RMV Imp: 880430 RMV Total: 1276970 MAV: 211750 MSAV: 38452 SAV: 62295
 Comment: 22-23: L2 4.11.23 ML

OLD
Notations 24-25: Demo of house and BARN

RP/MS	Code	Description
RP	ZONED	FARM EFU ZONED

OSDs

Count	Code	Description	RMV	Code Area	Exception
1	SAF	SA OSD - FAIR <i>AVLB</i>	35000	14530	0

Land

Site: 2 Code Area: 14530 Size: 1.00 Acres Use Code: 005 Zone: REST SAV Use: 011 Exception: 0
 Class: ~~2BDS~~ 2HD Value Source: Farm Homesite Description: TWO BENCH DRY SOUTH SPECIAL RMV: 50800 Exception: Y N
 Adjustment(s): VWGR, GSOIL, FSOIL Fire Patrol: Description:
 Comments: Liability year - 2009 / 00-01; UPDATED MARKET VALUE, 81400130

Site: 3 Code Area: 14530 Size: 7.20 Acres Use Code: 005 Zone: REST SAV Use: 011 Exception: 0
 Class: ~~2BDS~~ 2HD Value Source: Farm Use - EFU Description: TWO BENCH DRY SOUTH SPECIAL RMV: 113730 Exception: Y N
 Adjustment(s): VWGR, GSOIL, FSOIL Fire Patrol: Description:
 Comments: Liability year - 1981 / 00-01; UPDATED MARKET VALUE, 81400130

Site: 4 Code Area: 14530 Size: 3.20 Acres Use Code: 005 Zone: REST SAV Use: 011 Exception: 0
 Class: 6H Value Source: Farm Use - EFU Description: SIX HILL RMV: 43650 Exception: Y N
 Adjustment(s): VWGR, GSOIL, FSOIL Fire Patrol: Description:
 Comments: Liability year - 1981 / 81400130//08-09: 8BENCH PROJECT - CHG 8BENCH TO 6BENCH AND MOVE 9 ACRES TO 4BENCH AND REDUCE 2 BENCH BY 2 ACRES TO 4BENCH//

Site: 5 Code Area: 14530 Size: 10.68 Acres Use Code: 005 Zone: REST SAV Use: 011 Exception: 0
 Class: ~~4BD~~ 4HD Value Source: Farm Use - EFU Description: FOUR BENCH DRY RMV: 153360 Exception: Y N
 Adjustment(s): VWGR, GSOIL, FSOIL Fire Patrol: Description:
 Comments: Liability year - 1981 / 81400130//08-09: 8BENCH PROJECT - CHG 8BENCH TO 6BENCH AND MOVE 9 ACRES TO 4BENCH AND REDUCE 2 BENCH BY 2 ACRES TO 4BENCH//

Improvements - Residence / Manufactured Structures

Bldg: 7 Code Area: 14530 Stat Class: 143 Year Blt: 1964 Eff Year Blt: 1964 Sq.Ft: 2200 % Complete: 100
 Desc: One Story with basement Dimensions: RMV: 341300
 Func Obsc: 100 Econ %: 100 Other %: 100 Exception: 0 Adjust: Adjust RMV: 0

Floors

Type	Class	Display Group	Floor Size	Beds	Baths	Yr Blt	Eff Yr Blt	Inventory	Exception
First Floor	4	Finished	1575	3	FB-1	1964	1964	FP, HVAC, ROOF, KIT+, BATH - 1	Y N
Basement	4	Finished	625	1	FB-1	1964	1964	FP, HVAC, BATH - 1	Y N
Garage Attached	3	Unfinished	500	0	0	1964	1964	ROOF	Y N

Accessories

Description	Class	Size SqFt	Eff Yr Blt	RMV	Quantity	Exception
YARD IMPROVEMENTS FAIR	4	1	1964	12247	1	Y N

Bldg: 8 Code Area: 14530 Stat Class: 141 Year Blt: 2022 Eff Year Blt: 2022 Sq.Ft: 2305 % Complete: 100
 Desc: One Story Only Dimensions: RMV: 495100
 Func Obsc: 100 Econ %: 100 Other %: 100 Exception: 495100 Adjust: Adjust RMV: 0

Floors

Type	Class	Display Group	Floor Size	Beds	Baths	Yr Blt	Eff Yr Blt	Inventory	Exception
First Floor	4	Finished	2305	4	FB-2/ HB-1	2022	2022	KIT+, HVAC+, ROOF, BTH - 1, BATH - 2	Y N
Garage Attached	4	Finished	754	4	FB-2/ HB-1	2022	2022	ROOF	Y N

Accessories

Description	Class	Size SqFt	Eff Yr Blt	RMV	Quantity	
YARD IMPROVEMENTS AVERAGE	4	0	2022	28350	1	Exception: Y N

Improvements - Accessory Buildings

Bldg: 1	Code Area: 14530	Stat Class: 341	Year Blt: 1962	Eff Year Blt: 1962	Sq.Ft: 432	% Complete: 100
Desc: Multi Purpose Shed (MP)			Dimensions: 18x24		RMV: 1690	
Func Obsc: 100	Econ %: 100	Other %: 100	Exception: 0	Adjust:	Adjust RMV: 0	

Floors

Type	Class	Display Group	Floor Size	Beds	Baths	Yr Blt	Eff Yr Blt	Inventory	
Multi-Purpose Bldg	4	Finished	432	0	0	1962	1962		Exception: Y N

Accessories

Description	Class	Size SqFt	Eff Yr Blt	RMV	Quantity
No accessory data available					

Bldg: 2	Code Area: 14530	Stat Class: 312	Year Blt: 1962	Eff Year Blt: 1962	Sq.Ft: 1920	% Complete: 100
Desc: Loft Barn (LB)			Dimensions: 40x48		RMV: 6280	
Func Obsc: 50	Econ %: 100	Other %: 100	Exception: 0	Adjust:	Adjust RMV: 0	

Floors

Type	Class	Display Group	Floor Size	Beds	Baths	Yr Blt	Eff Yr Blt	Inventory	
Loft Barn	4	Finished	1920	0	0	1962	1962	FAIR	Exception: Y N

Accessories

Description	Class	Size SqFt	Eff Yr Blt	RMV	Quantity
No accessory data available					

Bldg: 3	Code Area: 14530	Stat Class: 312	Year Blt: 1999	Eff Year Blt: 1999	Sq.Ft: 2640	% Complete: 100
Desc: Loft Barn (LB)			Dimensions: 60x44		RMV: 26740	
Func Obsc: 50	Econ %: 100	Other %: 100	Exception: 0	Adjust:	Adjust RMV: 0	

Floors

Type	Class	Display Group	Floor Size	Beds	Baths	Yr Blt	Eff Yr Blt	Inventory	
Loft Barn	5	Finished	2640	0	0	1999	1999	FAIR	Exception: Y N

Accessories

Description	Class	Size SqFt	Eff Yr Blt	RMV	Quantity
No accessory data available					

Bldg: 4	Code Area: 14530	Stat Class: 355	Year Blt: 1999	Eff Year Blt: 1999	Sq.Ft: 720	% Complete: 100
Desc: Lean-to Heavy (LTH)			Dimensions: 60x12		RMV: 3160	
Func Obsc: 100	Econ %: 100	Other %: 100	Exception: 0	Adjust:	Adjust RMV: 0	

Floors

Type	Class	Display Group	Floor Size	Beds	Baths	Yr Blt	Eff Yr Blt	Inventory	
Lean-to Heavy Duty	4	Finished	720	0	0	1999	1999		Exception: Y N

Accessories

Description	Class	Size SqFt	Eff Yr Blt	RMV	Quantity
No accessory data available					

Bldg: 5	Code Area: 14530	Stat Class: 355	Year Blt: 1999	Eff Year Blt: 1999	Sq.Ft: 720	% Complete: 100
Desc: Lean-to Heavy (LTH)			Dimensions: 60x12		RMV: 3160	
Func Obsc: 100	Econ %: 100	Other %: 100	Exception: 0	Adjust:	Adjust RMV: 0	

Floors

Type	Class	Display Group	Floor Size	Beds	Baths	Yr Blt	Eff Yr Blt	Inventory	
Lean-to Heavy Duty	4	Finished	720	0	0	1999	1999		Exception: Y N

Accessories

Description	Class	Size SqFt	Eff Yr Blt	RMV	Quantity
No accessory data available					

Bldg: 6	Code Area: 14530	Stat Class: 341	Year Blt: 2000	Eff Year Blt: 2000	Sq.Ft: 192	% Complete: 100
Desc: Multi Purpose Shed (MP)			Dimensions: 16x12		RMV: 3000	
Func Obsc: 100	Econ %: 100	Other %: 100	Exception: 0	Adjust:	Adjust RMV: 0	

Floors

Type	Class	Display Group	Floor Size	Beds	Baths	Yr Blt	Eff Yr Blt	Inventory	
Multi-Purpose Bldg	5	Finished	192	0	0	2000	2000		Exception: Y N

Accessories

Description	Class	Size SqFt	Eff Yr Blt	RMV	Quantity
No accessory data available					

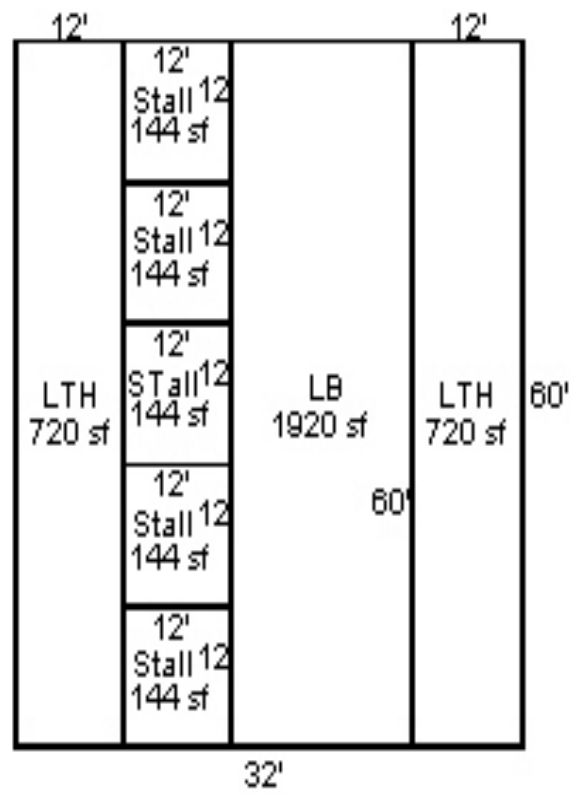

Other Structures South



SKETCH/AREA TABLE ADDENDUM

SUBJECT INFO

File No.: 536470 Parcel No.: 093W24 00100
 Property Address: 2947 WINTERCREEK ROAD SE
 City: JEFFERSON County: State: OR ZipCode: 97392
 Owner:
 Client: Client Address:
 Appraiser Name: Inspection Date:

SKETCH

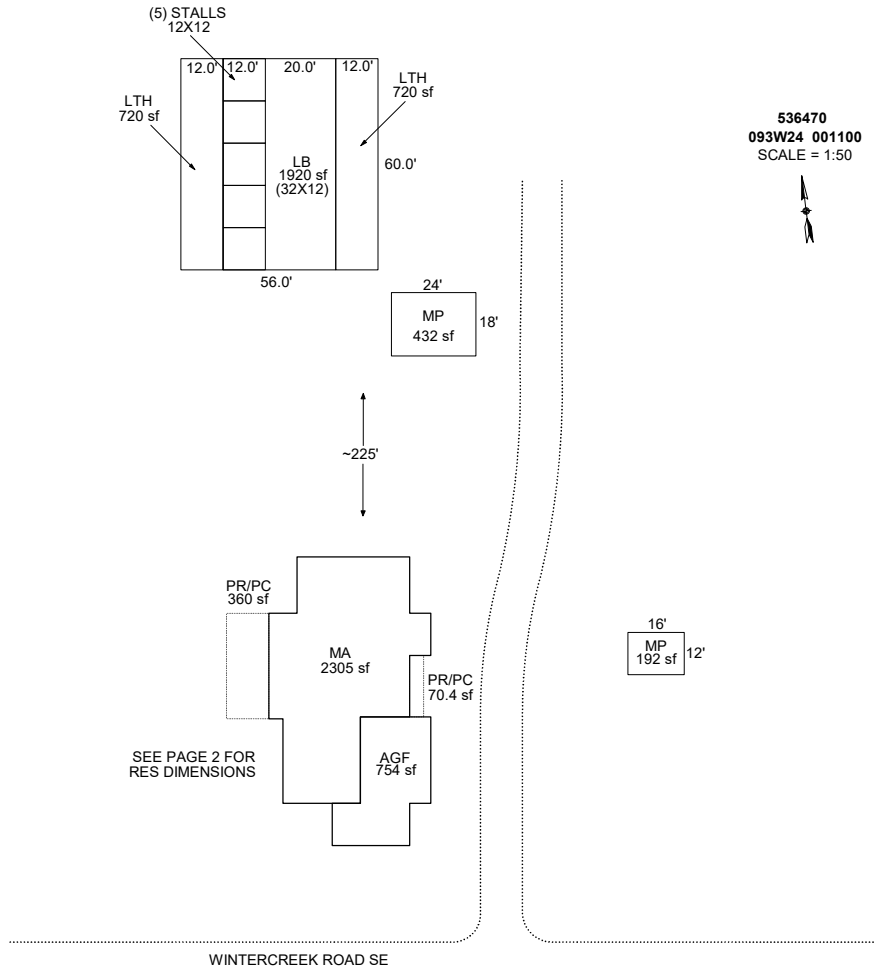

Sketch by Apex Sketch

AREA CALCULATIONS SUMMARY						COMMENT TABLE 1	
Code	Description	Factor	Net Size	Perimeter	Net Totals		
GLA1	MA	1.0	2305.0	232.0	2305.0	Apex by JA 5/04/09 UPDATED BY CJURAN 01/21/2022 555-21-011843 UPDATED BY CJURAN 12/12/2023	
GAR	AGF	1.0	754.0	129.0	754.0		
OTH	MP	1.0	192.0	56.0			
	MP	1.0	432.0	84.0			
	Stall	1.0	144.0	48.0			
	STall	1.0	144.0	48.0			
	Stall	1.0	144.0	48.0			
P/P	Stall	1.0	144.0	48.0			
	LB	1.0	1920.0	184.0			
	LTH	1.0	720.0	144.0	4704.0		
	LTH	1.0	720.0	144.0			
	PR/PC	1.0	70.4	43.0			
	PR/PC	1.0	360.0	84.0	430.4	COMMENT TABLE 2	COMMENT TABLE 3
	Net LIVABLE	cnt	1 (rounded)		2,305	MDL 10/15/2023	TAGS L3

SKETCH/AREA TABLE ADDENDUM

SUBJECT INFO

File No.: 536470 Parcel No.: 093W24 00100
 Property Address: 2947 WINTERCREEK ROAD SE
 City: JEFFERSON County: State: OR ZipCode: 97392
 Owner:
 Client: Client Address:
 Appraiser Name: Inspection Date:

SKETCH

536470
093W24 001100
 SCALE = 1:20



SEE PAGE 1 FOR
ALL BLDGS

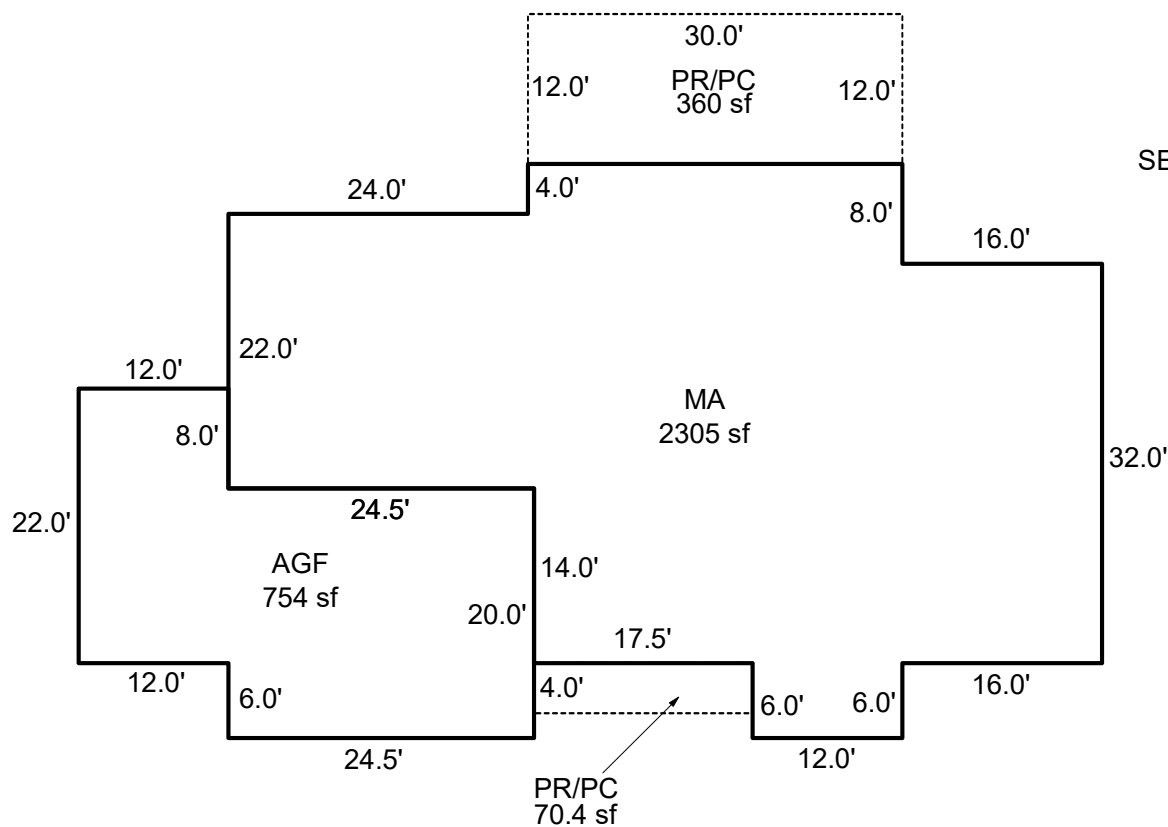

Sketch by Apex Sketch

AREA CALCULATIONS SUMMARY

Code	Description	Factor	Net Size	Perimeter	Net Totals
GLA1	MA	1.0	2305.0	232.0	2305.0
GAR	AGF	1.0	754.0	129.0	754.0
P/P	PR/PC	1.0	360.0	84.0	
	PR/PC	1.0	70.4	43.0	430.4

COMMENT TABLE 1

Apex by JA 5/04/09
 UPDATED BY CJURAN 01/21/2022 555-21-011843
 UPDATED BY CJURAN 12/12/2023

COMMENT TABLE 2

MDL 10/15/2023

COMMENT TABLE 3

TAGS L3

Net LIVABLE cnt 1 (rounded) 2,305

SKETCH/AREA TABLE ADDENDUM

SUBJECT INFO

File No.: 536470 Parcel No.: 093W24 00100
 Property Address: 2947 WINTERCREEK ROAD SE
 City: JEFFERSON County: State: OR ZipCode: 97392
 Owner:
 Client: Client Address:
 Appraiser Name: Inspection Date:

SKETCH

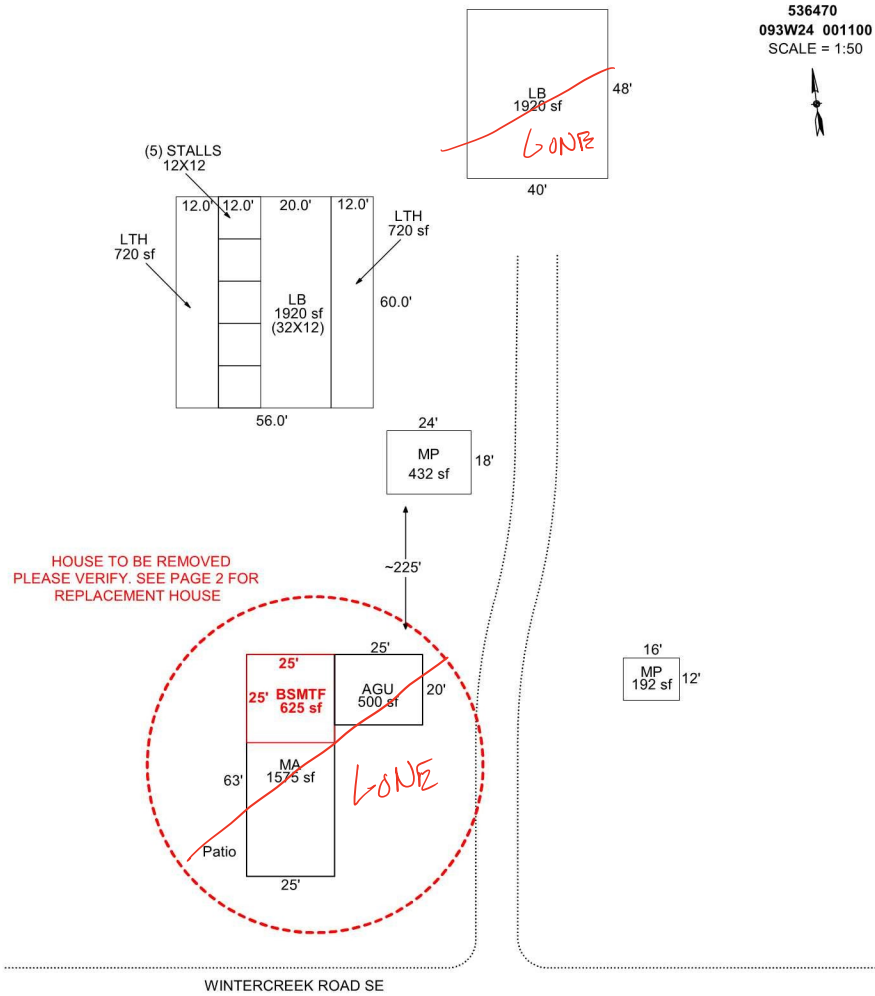

AREA CALCULATIONS SUMMARY

COMMENT TABLE 1

Code	Description	Factor	Net Size	Perimeter	Net Totals
GLA1	MA	1.0	1575.0	176.0	1575.0
BSMT	BSMTF	1.0	625.0	100.0	625.0
GAR	AGU	1.0	500.0	90.0	500.0
OTH	MP	1.0	192.0	56.0	
	MP	1.0	432.0	84.0	
	LB	1.0	1920.0	176.0	
	Stall	1.0	144.0	48.0	
	Stall	1.0	144.0	48.0	
	Stall	1.0	144.0	48.0	
	Stall	1.0	144.0	48.0	
	Stall	1.0	144.0	48.0	
	LB	1.0	1920.0	184.0	
	LTH	1.0	720.0	144.0	
	LTH	1.0	720.0	144.0	6624.0
	Net LIVABLE	cnt	1 (rounded)		1,575

Apex by JA 5/04/09
 UPDATED BY CJURAN 01/21/2022 555-21-011843

COMMENT TABLE 2

COMMENT TABLE 3

SKETCH/AREA TABLE ADDENDUM

SUBJECT INFO

File No.: 536470 Parcel No.: 093W24 00100
 Property Address: 2947 WINTERCREEK ROAD SE
 City: JEFFERSON County: State: OR ZipCode: 97392
 Owner:
 Client: Client Address:
 Appraiser Name: Inspection Date:

SKETCH

536470
093W24 001100
 SCALE = 1:20



SEE PAGE 1 FOR
ALL BLDGS

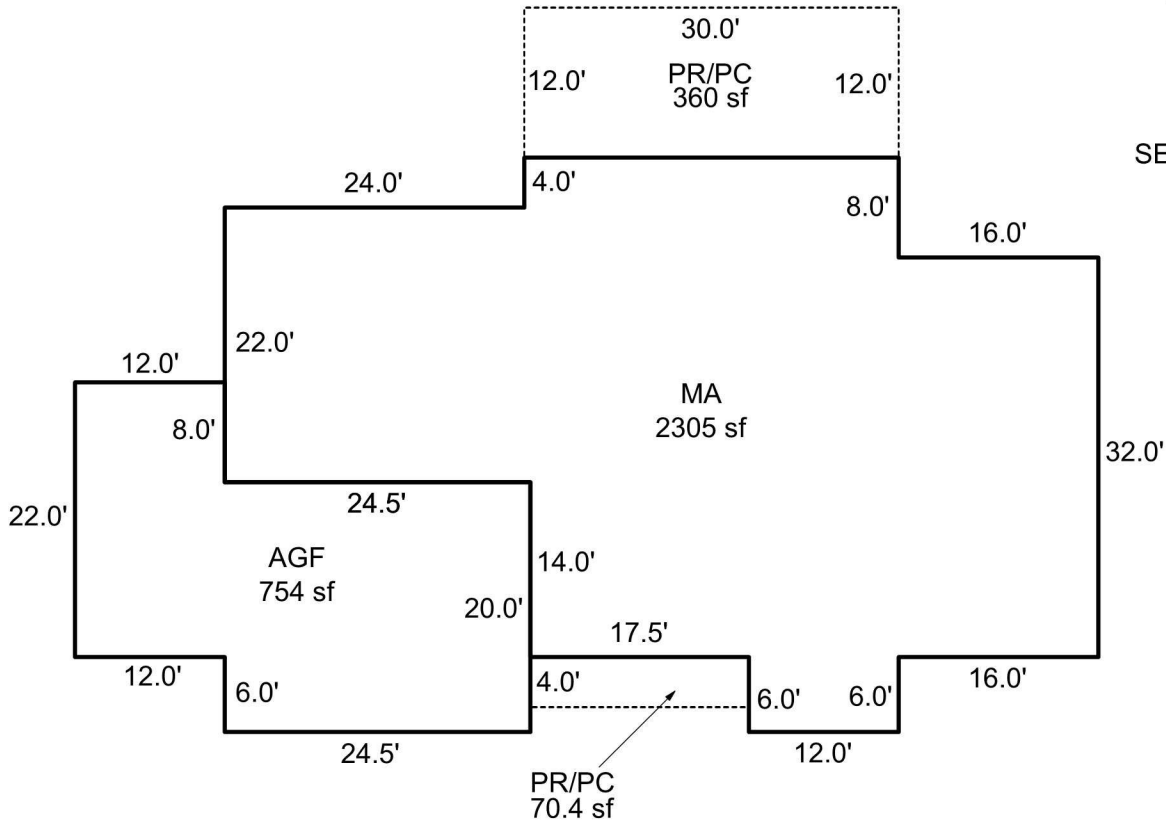

Sketch by Apex Sketch

AREA CALCULATIONS SUMMARY

Code	Description	Factor	Net Size	Perimeter	Net Totals
GLA1	MA	1.0	2305.0	232.0	2305.0
GAR	AGF	1.0	754.0	129.0	754.0
P/P	PR/PC	1.0	360.0	84.0	
	PR/PC	1.0	70.4	43.0	430.4

COMMENT TABLE 1

Apex by JA 5/04/09
 UPDATED BY CJURAN 01/21/2022 555-21-011843

COMMENT TABLE 2

COMMENT TABLE 3

Net LIVABLE cnt 1 (rounded) 2,305







