

# SKETCH/AREA TABLE ADDENDUM

## SUBJECT INFO

File No.: R135947 Parcel No.: 073W35CC04300  
 Property Address: 2777 12TH PL SE  
 City: SALEM County: State: OR ZipCode: 97302  
 Owner:  
 Client: Client Address:  
 Appraiser Name: Inspection Date:

## SKETCH

**135947**  
**073W35CC04300**

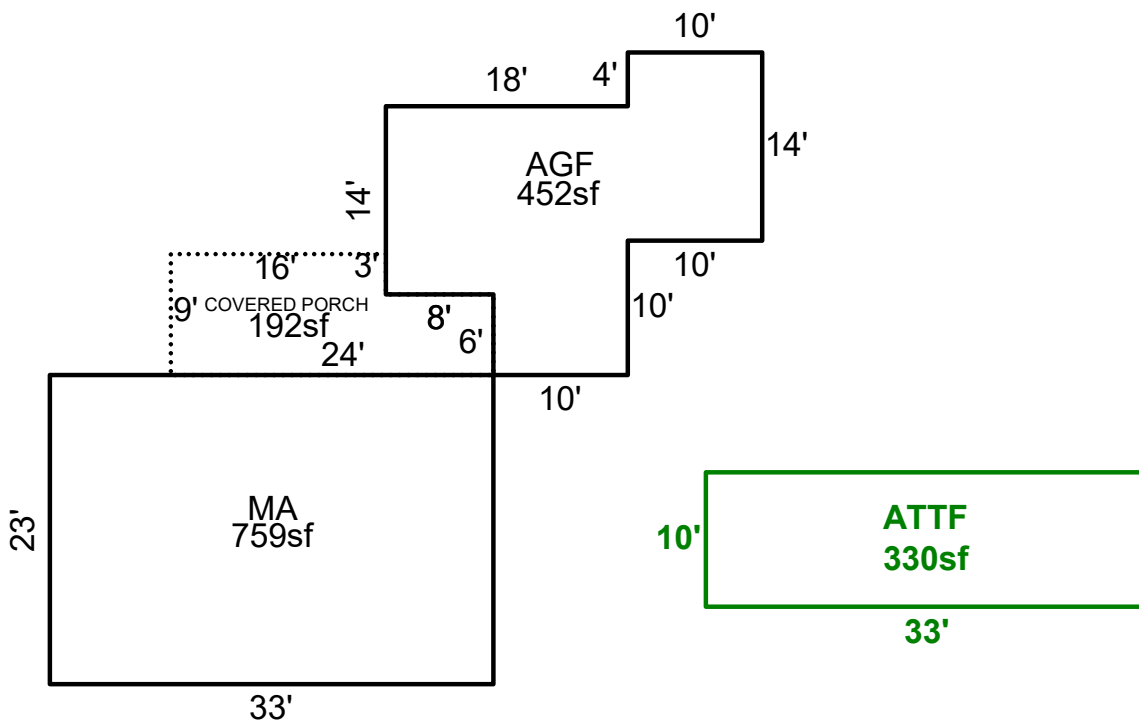

Sketch by ApexSketch

### AREA CALCULATIONS SUMMARY

Code	Description	Factor	Net Size	Perimeter	Net Totals
GLA	MA	1.0	759.0	112.0	759.0
GLA2	ATTFF	1.0	330.0	86.0	330.0
GAR	AGF	1.0	452.0	104.0	452.0
P/P	COVERED PORCH	1.0	192.0	66.0	192.0

### COMMENT TABLE 1

APEX BY JA 2/12/14 PER SKETCH

### COMMENT TABLE 2

### COMMENT TABLE 3

Net LIVABLE                      cnt                      2      (rounded)                      1,089