

# SKETCH/AREA TABLE ADDENDUM

## SUBJECT INFO

File No.: 596983 Parcel No.: 073W34AD06300  
 Property Address: 2075 UNIVERSITY ST SE  
 City: SALEM County: MARION State: OR ZipCode: 97302  
 Owner:  
 Client: Client Address:  
 Appraiser Name: Inspection Date:

## SKETCH

**596983**  
**073W34AD06300**

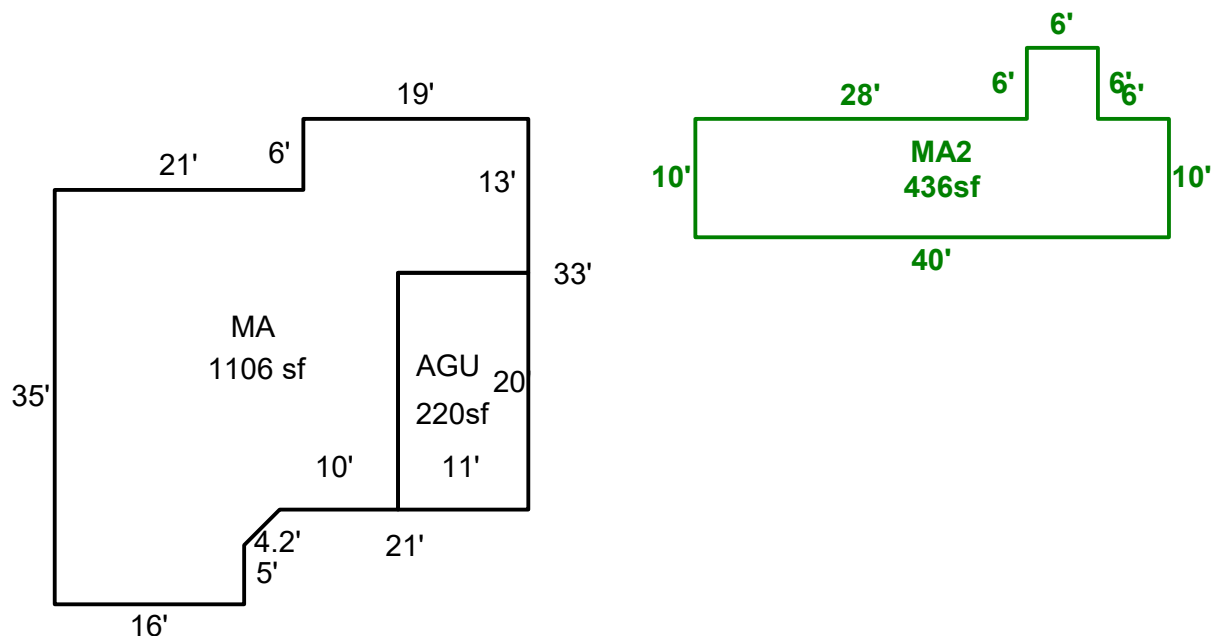

Sketch by ApexSketch

AREA CALCULATIONS SUMMARY						COMMENT TABLE 1		
Code	Description	Factor	Net Size	Perimeter	Net Totals			
GLA	MA	1.0	1106.5	160.2	1106.5	Drawn by PT 2/10/12 UPDATED BY JRONDEMA 9/8/15 UPDATED BY LK 11.25.24		
GLA2	MA2	1.0	436.0	112.0	436.0			
GAR	AGU	1.0	220.0	62.0	220.0			
Net LIVABLE						cnt	2 (rounded)	1,543
						COMMENT TABLE 2	COMMENT TABLE 3	
						7/21/15 #72 10.18.24 SV GM	NV-CYCLE	