

Acct ID: 529823 MTL: 082W15D004100 Date: 9/26/24 Appr: MDL Prop Class: 451 RMV Prop Class: 451
 Situs: 7461 RAYONA DR SE SALEM OR 97317 MaSaNh: 07 06 000 Unit: 89335 Year: ~~2024~~ 2025
 Last Date Appraised: 07/27/2021 Appraiser: MATT LORD Retag: Y (N) Tag info: 2025 - Tags/Permit (Alt Energy System)
 Owner: CHRISTOPHER A CLARK FAM TR & Roll Type: R
 Cycle (Tag) Sales Verification Other: _____ Inspection level: 1 2 3 (4) LCB TTO INSP AV: 267360
 RMV Land: 208960 RMV Imp: 272370 RMV Total: 481330 MAV: 267360 MSAV: 0 SAV: 0
 Comment: LEVEL 3 7.27.21 ML-T40

Notations 25-26 TAB SOLAR \$1500

RP/MS	Code	Description
RP	PERM	PERMANENTLY DISQUALIFIED FROM FARM/FOREST

OSDs

Count	Code	Description	RMV	Code Area	Exception
1	MKTA	OSD - AVERAGE	45000	05550	0

Land

Site: 1 Code Area: 05550 Size: 1.11 Acres Use Code: 005 Zone: REST SAV Use: Exception: 0
 Class: ZBDSS Value Source: Permanently Disqualified Description: RMV: 163960 Exception: Y N
 Adjustment(s): 6500 Fire Patrol: Description:
 Comments: 2002-03 REAPPRAISAL; 2003-04 MODIFIED LAND TABLE KKB65 10/02

Improvements - Residence / Manufactured Structures

Bldg: 1 Code Area: 05550 Stat Class: 131 Year Blt: 1985 Eff Year Blt: 1992 Sq.Ft: 1467 % Complete: 100
 Desc: One Story Only Dimensions: RMV: 200470
 Func Obsc: 100 Econ %: 100 Other %: 100 Exception: 0 Adjust: Adjust RMV: 0

Floors

Type	Class	Display Group	Floor Size	Beds	Baths	Yr Blt	Eff Yr Blt	Inventory	Exception
First Floor	3	Finished	1467	2	FB-2	1985	1992	BATH - 2, KIT, ROOF, HVAC+, FP - 1	Y N

Accessories

VIA

Description	Class	Size SqFt	Eff Yr Blt	RMV	Quantity	Exception
DECK	3	1040	2009	19344	1	Y N
PATIO	3	120	2010	620	1	Y N
ROOF EXTENSION OR PATIO COVER	3	50	1992	1233	1	Y N

Bldg: 3 Code Area: 05550 Stat Class: 138 Year Blt: 2010 Eff Year Blt: 2010 Sq.Ft: 0 % Complete: 100
 Desc: Res other improvements Dimensions: RMV: 63980
 Func Obsc: 100 Econ %: 100 Other %: 100 Exception: 0 Adjust: Adjust RMV: 0

Floors

Type	Class	Display Group	Floor Size	Beds	Baths	Yr Blt	Eff Yr Blt	Inventory	Exception
Garage Attached	3	Finished	806	0	0	2010	2010	ROOF	Y N

Accessories

ADD TO MKTA

Description	Class	Size SqFt	Eff Yr Blt	RMV	Quantity	Exception
CONCRETE DRIVEWAY	3	650	2010	1985	1	Y N

Improvements - Accessory Buildings

Bldg: 2 Code Area: 05550 Stat Class: 351 Year Blt: 1990 Eff Year Blt: 1990 Sq.Ft: 1080 % Complete: 100
 Desc: General Purpose Building (GB) Dimensions: 36x30 RMV: 7920
 Func Obsc: 100 Econ %: 100 Other %: 100 Exception: 0 Adjust: Adjust RMV: 0

Floors

Type	Class	Display Group	Floor Size	Beds	Baths	Yr Blt	Eff Yr Blt	Inventory	Exception
General Purpose Bldg	5	Finished	1080	0	0	1990	1990	FAIR	Y N

Accessories

Description	Class	Size SqFt	Eff Yr Blt	RMV	Quantity
No accessory data available					

SKETCH/AREA TABLE ADDENDUM

SUBJECT INFO

File No.: R29823 Parcel No.: 082W15D 04100
 Property Address: 7641 RAYONA DR SE
 City: SALEM County: MARION State: OR ZipCode: 97317
 Owner:
 Client: Client Address:
 Appraiser Name: Inspection Date:

SKETCH

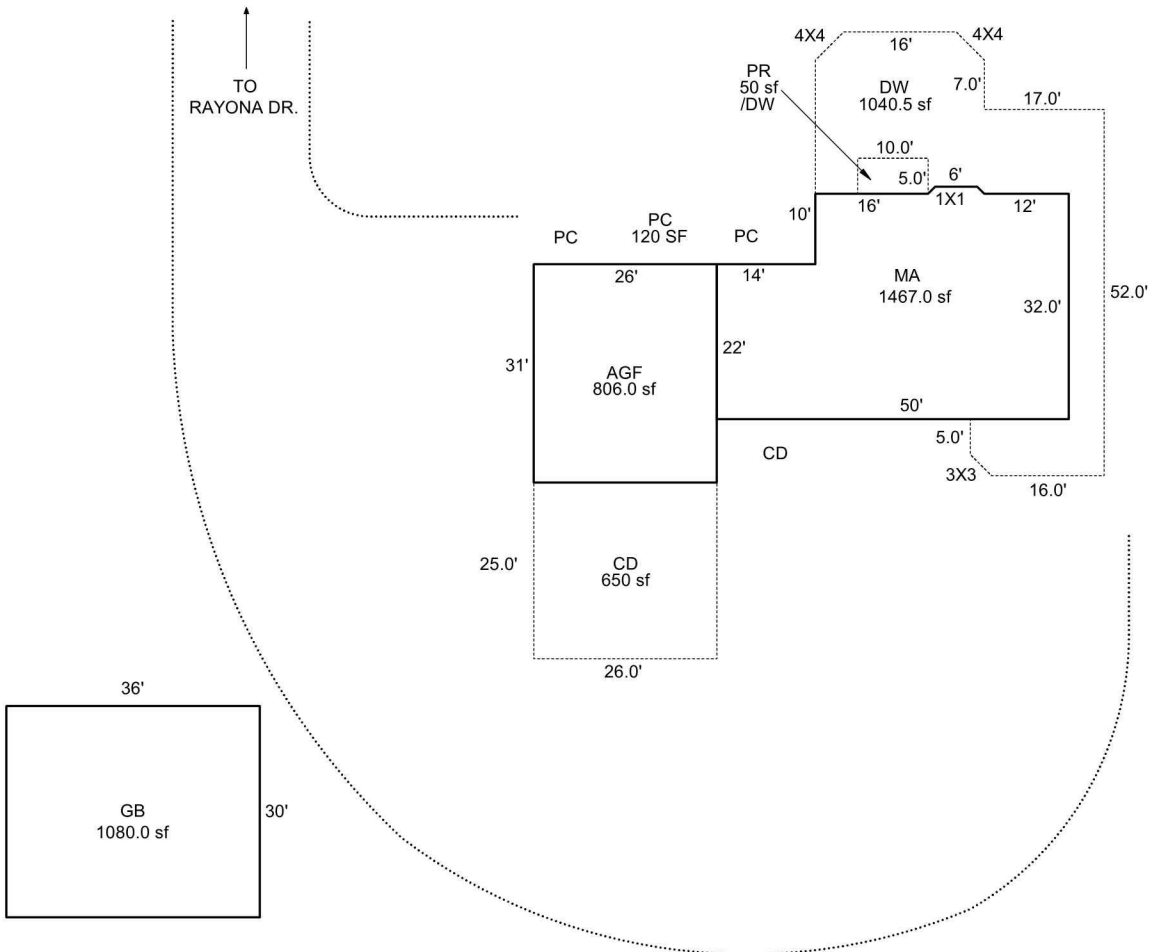

R29823
082W15D 04100
SCALE = 1:20

Sketch by Apex Sketch

AREA CALCULATIONS SUMMARY

Code	Description	Factor	Net Size	Perimeter	Net Totals
GBA1	GB	1.0	1080.0	132.0	1080.0
GLA1	MA	1.0	1467.0	164.8	1467.0
GAR	AGF	1.0	806.0	114.0	806.0
P/P	DW	1.0	1040.5	230.4	
	CD	1.0	650.0	102.0	
	PR	1.0	50.0	30.0	1740.5

COMMENT TABLE 1

DRAWN BY SH 2-4-10
 Updated to add AGF and CD 12/17/10 Jane
 UPDATED BY CJURAN 07/29/2021

COMMENT TABLE 2

#T40 ML 07/28/2021

COMMENT TABLE 3

CYCLE

Net LIVABLE	cnt	1	(rounded)	1,467
Net BUILDING	cnt	1	(rounded)	1,080



R29823 House E DW PR
2021-07-28 L2



R29823 GB 25 X 26
2021-07-28 L2



R29823 AGF CD
2021-07-28 L2



R29823 House E side
2021-07-28 L2