

Summary Lead Appr: WW 11.26.24 Clerk: Lead Clerk: Appr: GRH Print Date:

9/24/2024

Acct ID: 531752 MTL: 083W08BC00700 Date: 11/19/24 Appr: GRH Prop Class: 401 RMV Prop Class: 401
Situs: 4428 CROISAN RIDGE WAY S SALEM OR 97306 MaSaNh: 06 06 004 Unit: 147914 Year: 2024

Last Date Appraised: 01/24/2024 Appraiser: WENDY WILLIAMS Retag: Y N Tag info: 2024 - Tags/Permit (Miscellaneous)

Owner: BANDY J GILLIES RT Roll Type: R

Cycle: Tag Sales Verification Other: Inspection level: 1 2 3 4 LCB TTO INSP AV: 296290

RMV Land: 257800 RMV Imp: 379890 RMV Total: 637690 MAV: 97000 MSAV: 0 SAV: 0

Comment: 24-25: L2 1.24.24 WW
23-24: L2 07.25.23 WW

Notations New MA @ 100%.

No notation data available.

OSDs

Count	Code	Description	RMV	Code Area	Exception
1	MKTN	OSD - NO LANDSCAPE	30000	92430	14590

Land

Good m/m

Site: 1 Code Area: 92430 Size: 2.00 Acres Use Code: 004 Zone: NREST SAV Use: Exception: 0
 Class: 4BDS Value Source: Rural at MKT Description: FOUR BENCH DRY SPECIAL SOUTH RMV: 227800 Exception: Y N
 Adjustment(s): Fire Patrol: Description:
 Comments: 01-02: REAPPRAISAL //07-08: PT OF R31751,R31752 AND R31756 - LAND LOCKED

Improvements - Residence / Manufactured Structures

Bldg: 1 Code Area: 92430 Stat Class: 151 - Year Blt: 2023 Eff Year Blt: 2023 Sq.Ft: 2372 % Complete: 55
 Desc: One Story Only Dimensions: RMV: 306670 100
 Func Obsc: 100 Econ %: 100 Other %: 100 Exception: 149100 Adjust: Adjust RMV: 0

Floors

Type	Class	Display Group	Floor Size	Beds	Baths	Yr Blt	Eff Yr Blt	Inventory	Exception	Y	N
First Floor	5 -	Finished	2372	3	FB-2/ HB-1	2023	2023	ROOF, BATH - 2, BATH+, BTH - 1, FP - 1, KIT+, HVAC+	Exception	Y	N
Garage Attached	5 -	Finished	780	0	0	2023	2023	ROOF	Exception	Y	N

AVRG

Accessories

Description	Class	Size SqFt	Eff Yr Blt	RMV	Quantity
No accessory data available					

Bldg: 2 Code Area: 92430 Stat Class: 148 Year Blt: 2023 Eff Year Blt: 2023 Sq.Ft: 0 % Complete: 55
 Desc: Res other improvements Dimensions: RMV: 73220 100
 Func Obsc: 100 Econ %: 100 Other %: 100 Exception: 35600 Adjust: Adjust RMV: 0

Floors

Type	Class	Display Group	Floor Size	Beds	Baths	Yr Blt	Eff Yr Blt	Inventory	Exception	Y	N
Garage Oversized Detached	4	Finished	1620	0	0	2023	2023	ROOF	Exception	Y	N

Accessories

Description	Class	Size SqFt	Eff Yr Blt	RMV	Quantity
No accessory data available					

Improvements - Accessory Buildings

No improvement data available for all other stat class types.

SKETCH/AREA TABLE ADDENDUM

SUBJECT INFO

File No.: 531752 Parcel No.: 083W08BC00700
 Property Address: 4428 CROISAN RIDGE WAY S
 City: Salem County: Marion State: OR ZipCode: 97302
 Owner:
 Client: Client Address:
 Appraiser Name: Inspection Date:

SKETCH

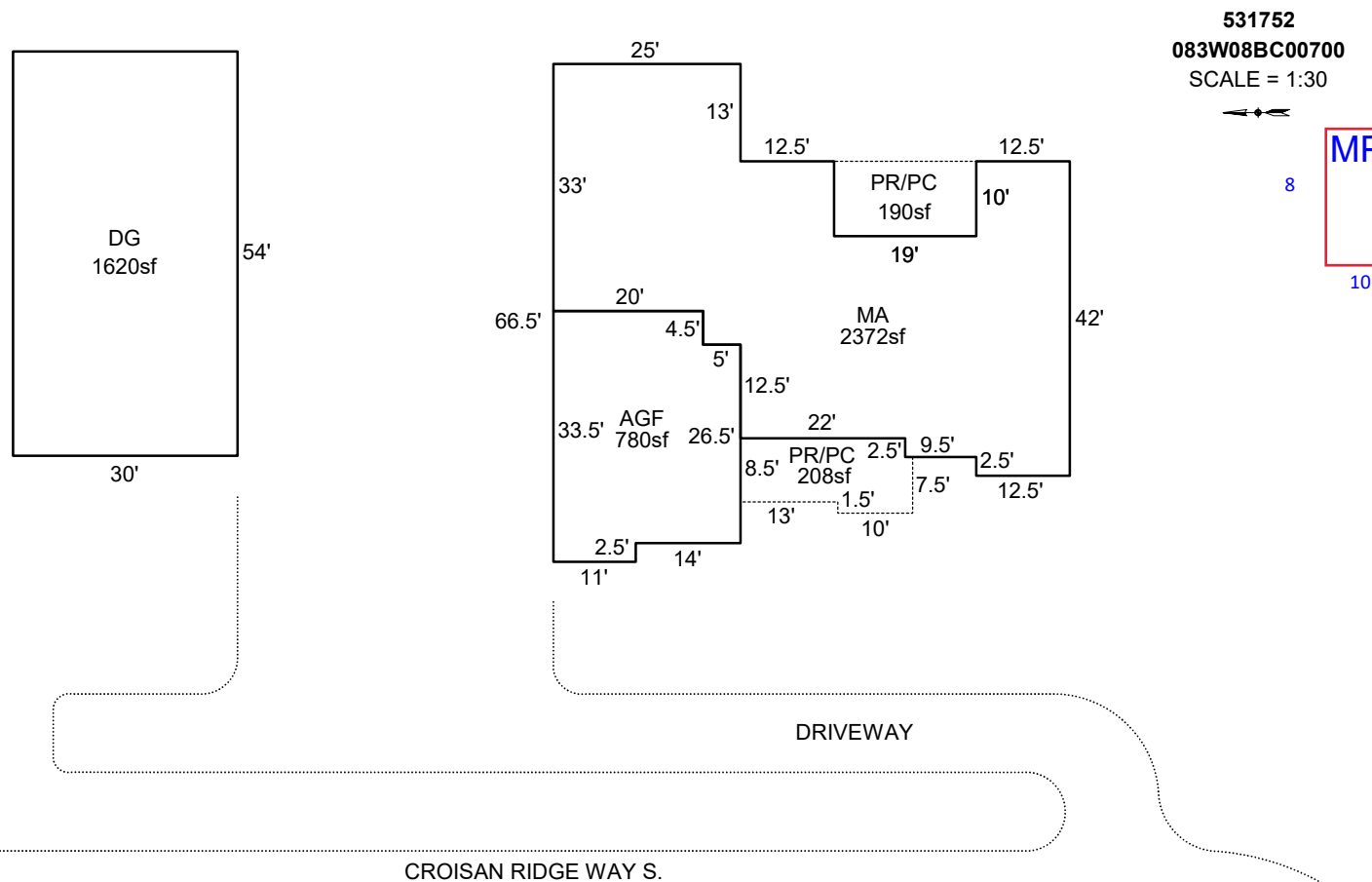

AREA CALCULATIONS SUMMARY

Code	Description	Factor	Net Size	Perimeter	Net Totals
GBA1	DG	1.0	1620.0	168.0	1620.0
GLA1	MA	1.0	2371.8	268.0	2371.8
GAR	AGF	1.0	780.0	117.0	780.0
P/P	PR/PC	1.0	190.0	58.0	
	PR/PC	1.0	208.0	66.0	398.0

COMMENT TABLE 1

APEX BY CJURAN 10/17/2023 23-006950 DG
 APEX BY CJURAN 10/17/2023 23-006947 MA

COMMENT TABLE 2

GPH 11/14/24

COMMENT TABLE 3

TAGS L3

Net LIVABLE	cnt	1	(rounded)		2,372
Net BUILDING	cnt	1	(rounded)		1,620

