

Acct ID: 563307 MTL: 082W23A001700 Date: **10/24** Appr: **CLUKE** Prop Class: 401 RMV Prop Class: 401
 Situs: 6072 KASA LN SE AUMSVILLE OR 97325 MaSaNh: 01 06 000 Unit: 114302 Year: 2024
 Last Date Appraised: 01/09/2024 Appraiser: CLINT LUKE Retag: **N** Tag info: 2025 - Tags/Permit (Completion)
 Owner: MILTON, CORY Roll Type: R
 Cycle: **Tag** Sales Verification Other: _____ Inspection level: 1 2 3 **4** LCB TTO INSP AV: 423152
 RMV Land: 325700 RMV Imp: 520190 RMV Total: 845890 MAV: 412082 MSAV: 0 SAV: 0
 Comment: 24-25 L3 1/9/24 CLUKE
 LEVEL 4 C19 5-6-20 JS29

INPUT
11-15-24
CLUKE

Notations **23-008957 GB FINALED 3/4/24**

No notation data available.

OSDs

Count	Code	Description	RMV	Code Area	Exception
1	MKTA	OSD - AVERAGE	45000	05558	0

Land

Site: 2	Code Area: 05558	Size: 1.23 Acres	Use Code: 004	Zone: NREST	SAV Use:	Exception: 0
Class: 4HD	Value Source: Rural at MKT	Description: FOUR HILL DRY	RMV: 103650	Exception: Y	N	
Adjustment(s): GSOIL	Fire Patrol:	Description:				
Comments: 21-22: #29 CYCLE C19, NO CHG //17-18: DISQ 3.14 ACRES FARM USE//05-06: CHG OF RECALCULATION LAND TABLE PER #29						
Site: 3	Code Area: 05558	Size: 1.91 Acres	Use Code: 004	Zone: NREST	SAV Use:	Exception: 0
Class: 2BDS S	Value Source: Rural at MKT	Description: TWO BENCH DRY SOUTH SPECIAL	RMV: 177050	Exception: Y	N	
Adjustment(s): GSOIL	Fire Patrol:	Description:				
Comments: 21-22: #29 CYCLE C19, NO CHG //17-18: DISQ 3.14 ACRES FARM USE//05-06: CHG OF RECALCULATION LAND TABLE PER #29						

Improvements - Residence / Manufactured Structures

Bldg: 1	Code Area: 05558	Stat Class: 141	Year Blt: 2022	Eff Year Blt: 2022	Sq.Ft: 2444	% Complete: 100
Desc: One Story Only	Dimensions:	RMV: 497420				
Func Obsc: 100	Econ %: 100	Other %: 100	Exception: 0	Adjust:	Adjust RMV: 0	

Floors

Type	Class	Display Group	Floor Size	Beds	Baths	Yr Blt	Eff Yr Blt	Inventory	Exception:
First Floor	4	Finished	2444	3	FB-2/ HB-1	2022	2022	BATH - 2, HVAC, KIT, ROOF, BTH - 1	Y N
Garage Attached	4	Finished	856	0	0	2022	2022	ROOF	Y N

Accessories

Description	Class	Size SqFt	Eff Yr Blt	RMV	Quantity
YARD IMPROVEMENTS AVERAGE	4	0	2022	27900	1

Improvements - Accessory Buildings

Bldg: 2	Code Area: 05558	Stat Class: 351	Year Blt: 2023	Eff Year Blt: 2023	Sq.Ft: 1728	% Complete: 50
Desc: General Purpose Building (GB)	Dimensions: 48x36	RMV: 20340				
Func Obsc: 100	Econ %: 100	Other %: 100	Exception: 9890	Adjust:	Adjust RMV: 0	

Floors

Type	Class	Display Group	Floor Size	Beds	Baths	Yr Blt	Eff Yr Blt	Inventory	Exception:
General Purpose Bldg	5	Finished	1728	0	0	2023	2023	AVG	Y N

Accessories

Description	Class	Size SqFt	Eff Yr Blt	RMV	Quantity
No accessory data available					

Bldg: 3	Code Area: 05558	Stat Class: 355	Year Blt: 2023	Eff Year Blt: 2023	Sq.Ft: 720	% Complete: 100
Desc: Lean-to Heavy (LTH)	Dimensions: 36x20	RMV: 2430				
Func Obsc: 100	Econ %: 100	Other %: 100	Exception: 1180	Adjust:	Adjust RMV: 0	

Floors

Type	Class	Display Group	Floor Size	Beds	Baths	Yr Blt	Eff Yr Blt	Inventory	Exception:
Lean-to Heavy Duty	4	Finished	720	0	0	2023	2023		Y N

Accessories

Description	Class	Size SqFt	Eff Yr Blt	RMV	Quantity
No accessory data available					

SKETCH/AREA TABLE ADDENDUM

SUBJECT INFO

File No.: 563307 Parcel No.: 082W23E 01700
 Property Address: 6072 KASA LANE SE
 City: SALEM County: MARION State: OR ZipCode:
 Owner:
 Client: Client Address:
 Appraiser Name: Inspection Date:

SKETCH

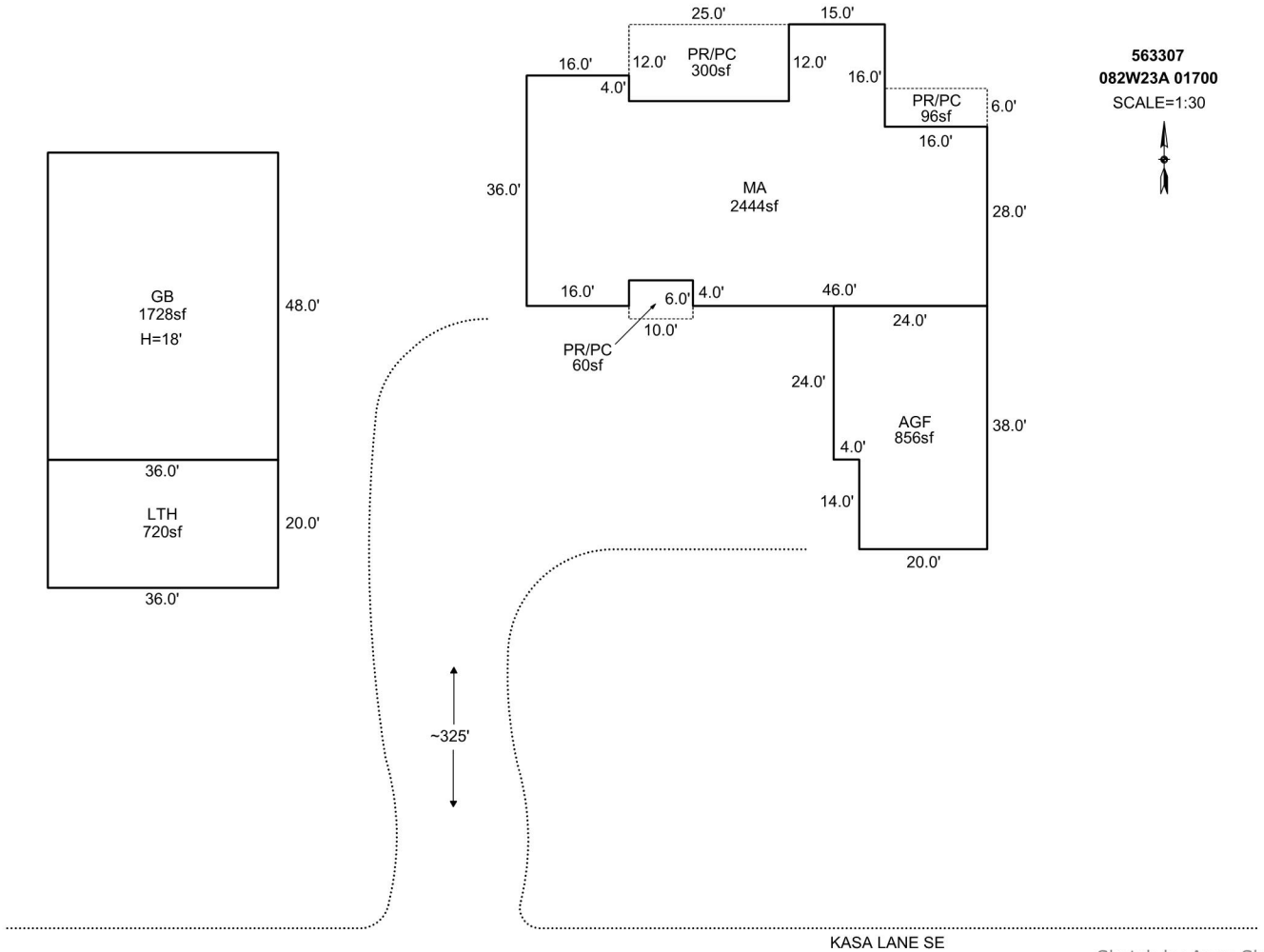

Sketch by Apex Sketch

AREA CALCULATIONS SUMMARY

Code	Description	Factor	Net Size	Perimeter	Net Totals
GBA1	GB	1.0	1728.0	168.0	
	LTH	1.0	720.0	112.0	2448.0
GLA1	MA	1.0	2444.0	248.0	2444.0
GAR	AGF	1.0	856.0	124.0	856.0
P/P	PR/PC	1.0	300.0	74.0	
	PR/PC	1.0	96.0	44.0	
	PR/PC	1.0	60.0	32.0	456.0

COMMENT TABLE 1

APEX BY CJURAN 08/23/2021 555-21-006703
 UPDATED BY CJURAN 12/13/2023 23-008957 GB

COMMENT TABLE 2

EVLE 1-9-24
EVLE 10-1-24

COMMENT TABLE 3

MISSED TAG L3
TAGS L4

Net LIVABLE	cnt	1	(rounded)	2,444
Net BUILDING	cnt	2	(rounded)	2,448