

SKETCH/AREA TABLE ADDENDUM

SUBJECT INFO

File No.: 333041 Parcel No.: 071W29 00401
 Property Address: 10850 SUNNYVIEW RD NE
 City: SALEM County: MARION State: OR ZipCode: 97301
 Owner:
 Client: Client Address:
 Appraiser Name: Inspection Date:

SKETCH

333041
071W29 00401
SCALE = 1:30

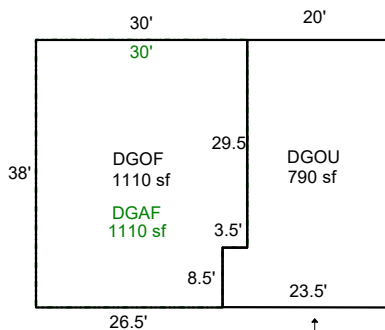

CHECK FOR LT & MPs

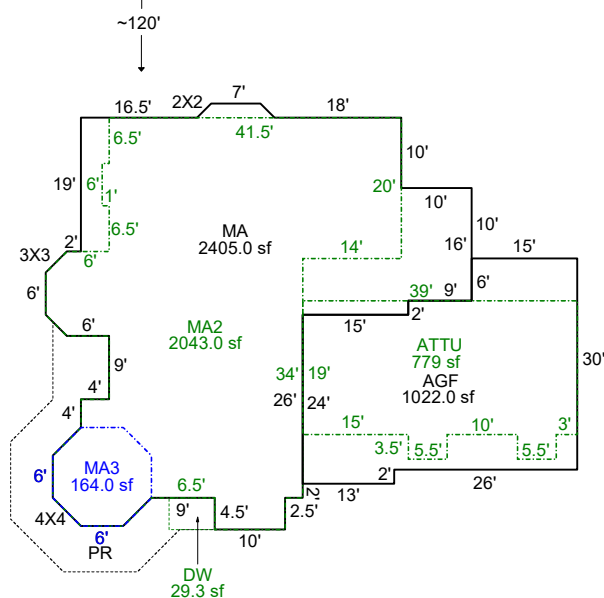

Sketch by ApexSketch

AREA CALCULATIONS SUMMARY						COMMENT TABLE 1	
Code	Description	Factor	Net Size	Perimeter	Net Totals		
GBA2	DGAF	1.0	1110.3	136.0	1110.3	DRAWN BY JRONDEMA 7/15/15 UPDATED BY CJURAN 05/08/2024 24-002251 DGF UPDATED BY CLOBERG 12/31/24	
GLA1	MA	1.0	2405.0	253.1	2405.0		
GLA2	MA2	1.0	2043.0	233.5			
	ATTU	1.0	779.5	130.0	2822.5		
GLA3	MA3	1.0	164.0	46.6	164.0		
GAR	AGF	1.0	1022.0	142.0			
	DGOF	1.0	1110.3	136.0			
	DGOU	1.0	789.3	123.0	2921.5		
P/P	PR	1.0	352.3	133.3			
	DW	1.0	29.3	22.0	381.6		
						COMMENT TABLE 2	COMMENT TABLE 3
						MLH 12/16/24	TAGS L4
		Net LIVABLE	cnt	0 (rounded)	5,392		
		Net BUILDING	cnt	1 (rounded)	1,110		