

Acct ID: 529260 MTL: 082W02C001200 Date: 12/12/24 Appr: CLW Prop Class: 401 RMV Prop Class: 401  
 Situs: 2428 74TH AVE SE SALEM OR 97317 MaSaNh: 01 06 004 Unit: 54238 Year: 2024

INPUT 1-10-25  
CLW

Last Date Appraised: 10/26/2023 Appraiser: CLINT LUKE Retag: N Tag info: 2025 - Tags/Permit (Completion)

Owner: KIRSCH, KEVIN J Roll Type: R

Cycle: Tag Sales Verification Other: \_\_\_\_\_ Inspection level: 1 2 3 4 LCB TTO INSP AV: 219640

RMV Land: 241350 RMV Imp: 321710 RMV Total: 563060 MAV: 219640 MSAV: 0 SAV: 0

Comment: 24-25: L2 10.26.23 GRH  
 23-24: L2 01.20.23 MLH//22-23: L2 09.21.21 CL  
 LEVEL 2 1.14.21 CL10

NO CHANGE POSTAG

Notations 20-004095 last INSP 1/4/21 AS OF 1/10/25  
 No notation data available.

**OSDs**

Count	Code	Description	RMV	Code Area	Exception
1	MKTA	OSD - AVERAGE	45000	92410	0

**Land**

Site: 1 Code Area: 92410 Size: 1.00 Acres Use Code: 004 Zone: NREST SAV Use: Exception: 0  
 Class: 2BDS Value Source: Rural at MKT Description: TWO BENCH DRY SOUTH SPECIAL RMV: 196350 Exception: Y N  
 S  
 Adjustment(s): GSOIL Fire Patrol: Description:  
 Comments: 02-03: REAPPRAISAL //04-05: LAND ADJUSTMENT PROJECT FOR RECALCULATION BY #31

**Improvements - Residence / Manufactured Structures**

Bldg: 1 Code Area: 92410 Stat Class: 131 + Year Blt: 2014 Eff Year Blt: 2014 Sq.Ft: 2034 % Complete: 100  
 Desc: One Story Only Dimensions: RMV: 281620  
 Func Obsc: 100 Econ %: 100 Other %: 100 Exception: 0 Adjust: Adjust RMV: 0

**Floors**

Type	Class	Display Group	Floor Size	Beds	Baths	Yr Blt	Eff Yr Blt	Inventory	Exception
First Floor	3 +	Finished	900	3	FB-2	2014	2014	BATH - 2, KIT-, ROOF, HVAC	Y N
First Floor	3 +	Finished	1134	0	0	2014	2014		Y N
Garage Attached	3 +	Finished	910	0	0	2021	2021	ROOF	Y N

**Accessories**

Description	Class	Size SqFt	Eff Yr Blt	RMV	Quantity	Exception
YARD IMPROVEMENTS FAIR	3	0	2014	8928	1	Y N

**Improvements - Accessory Buildings**

Bldg: 2 Code Area: 92410 Stat Class: 341 Year Blt: 1970 Eff Year Blt: 1970 Sq.Ft: 182 % Complete: 100  
 Desc: Multi Purpose Shed (MP) Dimensions: 14x13 RMV: 990  
 Func Obsc: 100 Econ %: 100 Other %: 100 Exception: 0 Adjust: Adjust RMV: 0

**Floors**

Type	Class	Display Group	Floor Size	Beds	Baths	Yr Blt	Eff Yr Blt	Inventory	Exception
Multi-Purpose Bldg	5	Finished	182	0	0	1970	1970	FAIR	Y N

**Accessories**

Description	Class	Size SqFt	Eff Yr Blt	RMV	Quantity	Exception
No accessory data available						

Bldg: 3 Code Area: 92410 Stat Class: 351 Year Blt: 2007 Eff Year Blt: 2007 Sq.Ft: 2880 % Complete: 100  
 Desc: General Purpose Building (GB) Dimensions: 72x40 RMV: 39100  
 Func Obsc: 100 Econ %: 100 Other %: 100 Exception: 0 Adjust: Adjust RMV: 0

**Floors**

Type	Class	Display Group	Floor Size	Beds	Baths	Yr Blt	Eff Yr Blt	Inventory	Exception
General Purpose Bldg	5	Finished	2880	0	0	2007	2007	FAIR	Y N

**Accessories**

Description	Class	Size SqFt	Eff Yr Blt	RMV	Quantity	Exception
No accessory data available						

# SKETCH/AREA TABLE ADDENDUM

## SUBJECT INFO

File No.: 529260 Parcel No.: 082W02C 01200  
 Property Address: 2428 74TH AV SE  
 City: SALEM County: MARION State: OR ZipCode: 97317  
 Owner:  
 Client: Client Address:  
 Appraiser Name: Inspection Date:

## SKETCH

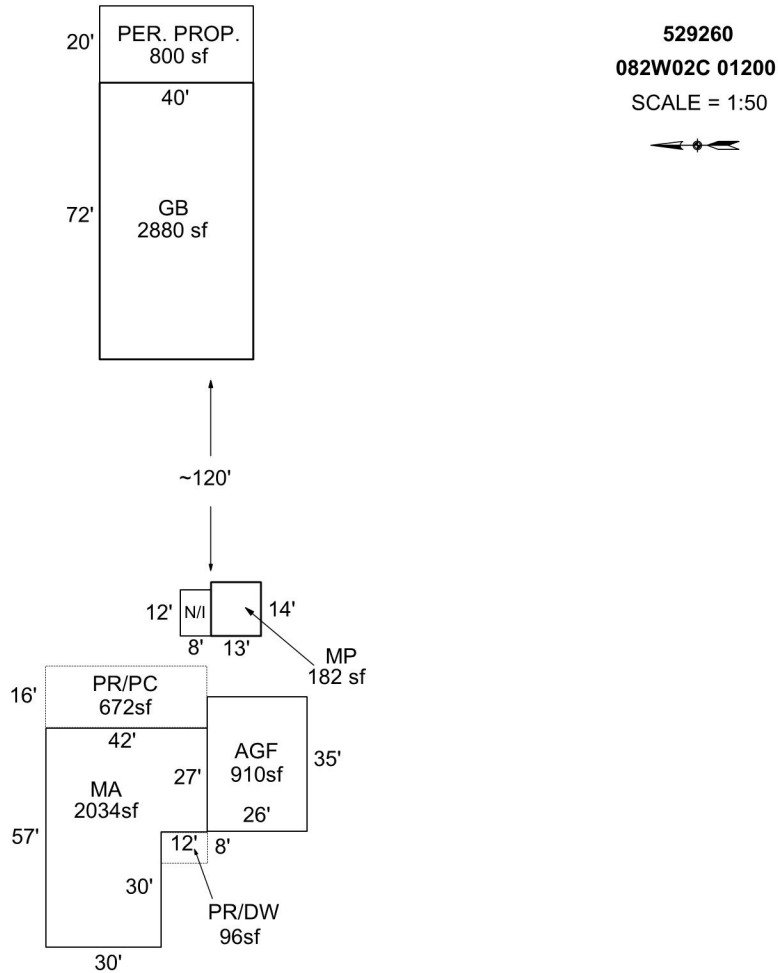

### AREA CALCULATIONS SUMMARY

Code	Description	Factor	Net Size	Perimeter	Net Totals
GBA1	MP	1.0	182.0	54.0	
	GB	1.0	2880.0	224.0	3062.0
GLA1	MA	1.0	2034.0	198.0	2034.0
GAR	AGF	1.0	910.0	122.0	910.0
P/P	PR/DW	1.0	96.0	40.0	
	PR/PC	1.0	672.0	116.0	768.0

### COMMENT TABLE 1

APEX BY CE 11/5/08  
 UPDATED BY SRAGSDALE 1/15/14  
 UPDATED BY JRONDEMA 4/28/15  
 UPDATED BY JRONDEMA 1/26/18  
 UPD BY PHU 12.15.20: 555-20-004095  
 UPDATED BY CJURAN 03/13/2023  
 UPDATED BY CJURAN 02/29/2024

### COMMENT TABLE 2

1/24/18 SR #94 TAGS  
 MLH 01/20/2023  
 GRH 10/26/2023

### COMMENT TABLE 3

TAGS L2  
 TAGS L2

Net LIVABLE	cnt	1	(rounded)	2,034
Net BUILDING	cnt	2	(rounded)	3,062



10/29/24



10/29/24