

Acct ID: 532928 MTL: 083W25B001100 Date: 12/17/24 Appr: MDL Prop Class: 501 RMV Prop Class: 501
 Situs: 6935 BATTLE CREEK RD SE SALEM OR 97317 MaSaNh: 07 06 000 Unit: 56463 Year: 2024

Last Date Appraised: 12/18/2023 Appraiser: MATT LORD Retag: Y N Tag info: 2025 - Tags/Permit (Miscellaneous)

Owner: BC SANCTUARY LLC Roll Type: R

Cycle Tag Sales Verification Other: _____ Inspection level: 1 2 3 4 LCB TTO INSP AV: 712430

RMV Land: 424280 RMV Imp: 963290 RMV Total: 1387570 MAV: 712430 MSAV: 0 SAV: 0

Comment: 24-25: L3 12.18.23 WW
 23-24: L3 12.30.22 GRH
 22-23: LEVEL 2 ML 11.10.21 // 22-23 L4 6/10/22 CLUKE

21-009784 USFB NOT started
23-000101 - NO start GARAGE *Permit for GARAGE*

Notations *25.26 USFB NO start / permit expired, Dwelling withdrawn, NO New construction*
 No notation data available.

OSDs

Count	Code	Description	RMV	Code Area	Exception
2	MKTG	OSD - GOOD	55000	92590	0

Land

Site: 1 Code Area: 92590 Size: 5.77 Acres Use Code: 005 Zone: REST SAV Use: Exception: 0
 Class: 4HD Value Source: Rural Restrictive Description: FOUR HILL DRY RMV: 119700 Exception: Y N
 Adjustment(s): H2OFR, GSOIL, IRR, FSOIL, GSOIL Fire Patrol: Description:
 Comments: 22-23 CHANGED WATER ADJUSTMENT TO FAIR

99-2000: DISQ FARM USE /00-01; REAPPRAISAL

Site: 2 Code Area: 92590 Size: 3.50 Acres Use Code: 005 Zone: REST SAV Use: Exception: 0
 Class: 4HI Value Source: Rural Restrictive Description: FOUR HILL IRR RMV: 57130 Exception: Y N
 Adjustment(s): H2OFR, GSOIL, IRR, FSOIL, GSOIL Fire Patrol: Description:
 Comments:

Site: 4 Code Area: 92590 Size: 3.35 Acres Use Code: 005 Zone: REST SAV Use: Exception: 0
 Class: 6H Value Source: Rural Restrictive Description: SIX HILL RMV: 49480 Exception: Y N
 Adjustment(s): H2OFR, GSOIL, IRR, FSOIL, GSOIL Fire Patrol: Description:
 Comments:

Site: 5 Code Area: 92590 Size: 7.98 Acres Use Code: 005 Zone: REST SAV Use: Exception: 0
 Class: 2HD Value Source: Rural Restrictive Description: TWO HILL DRY RMV: 136470 Exception: Y N
 Adjustment(s): H2OFR, GSOIL, IRR, FSOIL, GSOIL Fire Patrol: Description:
 Comments:

Site: 6 Code Area: 05590 Size: 0.38 Acres Use Code: 005 Zone: REST SAV Use: Exception: 0
 Class: 2HD Value Source: Rural Restrictive Description: TWO HILL DRY RMV: 6500 Exception: Y N
 Adjustment(s): H2OFR, GSOIL, IRR, FSOIL, GSOIL Fire Patrol: Description:
 Comments: 99-2000: DISQ FARMUSE /00-01; REAPPRAISAL

Improvements - Residence / Manufactured Structures

Bldg: 1 Code Area: 92590 Stat Class: 144 Year Blt: 1922 Eff Year Blt: 1977 Sq.Ft: 2540 % Complete: 100
 Desc: Multi Story above grade with basement Dimensions: RMV: 420490
 Func Obsc: 100 Econ %: 100 Other %: 100 Exception: 0 Adjust: Adjust RMV: 0

Floors

Type	Class	Display Group	Floor Size	Beds	Baths	Yr Blt	Eff Yr Blt	Inventory	Exception
First Floor	4	Finished	1400	1	FB-1/ HB-1	1922	1977	BATH - 1, BTH - 1, KIT-, ROOF, HVAC+, FP - 1	Y N
Attic	4	Finished	1140	3	FB-1	1922	1977	BATH - 1, HVAC+	Y N
Basement	4	Unfinished	1400	0	0	1922	1977		Y N

Accessories

Description	Class	Size SqFt	Eff Yr Blt	RMV	Quantity	Exception
YARD IMPROVEMENTS AVERAGE	4	0	1977	21483	1	Y N

Improvements - Accessory Buildings

Bldg: 2 Code Area: 92590 Stat Class: 352 Year Blt: 2005 Eff Year Blt: 2016 Sq.Ft: 9894 % Complete: 100
 Desc: Utility Building (UB) Dimensions: RMV: 524700
 Func Obsc: 100 Econ %: 100 Other %: 100 Exception: 0 Adjust: Adjust RMV: 0

Floors

Type	Class	Display Group	Floor Size	Beds	Baths	Yr Blt	Eff Yr Blt	Inventory	
Utility Building	6	Finished	9894	0	FB-2	2005	2016	BATH - 2, GOOD	Exception: Y N

Accessories

Description	Class	Size SqFt	Eff Yr Blt	RMV	Quantity	
FINISHED OFFICE IN A FARM BUILDING	6	9893	2016	287144	0	Exception: Y N

Bldg: 3 Code Area: 92590 Stat Class: 341 Year Blt: 2007 Eff Year Blt: 2007 Sq.Ft: 324 % Complete: 100
 Desc: Multi Purpose Shed (MP) Dimensions: 18x18 RMV: 13850
 Func Obsc: 100 Econ %: 100 Other %: 100 Exception: 0 Adjust: Adjust RMV: 0

Floors

Type	Class	Display Group	Floor Size	Beds	Baths	Yr Blt	Eff Yr Blt	Inventory	
Multi-Purpose Bldg	6	Finished	324	0	0	2007	2007	EXCLT	Exception: Y N

Accessories

Description	Class	Size SqFt	Eff Yr Blt	RMV	Quantity
No accessory data available					

Bldg: 4 Code Area: 92590 Stat Class: 341 Year Blt: 2007 Eff Year Blt: 2007 Sq.Ft: 288 % Complete: 100
 Desc: Multi Purpose Shed (MP) Dimensions: 12x24 RMV: 4250
 Func Obsc: 100 Econ %: 100 Other %: 100 Exception: 0 Adjust: Adjust RMV: 0

Floors

Type	Class	Display Group	Floor Size	Beds	Baths	Yr Blt	Eff Yr Blt	Inventory	
Multi-Purpose Bldg	4	Finished	288	0	0	2007	2007	FAIR	Exception: Y N

Accessories

Description	Class	Size SqFt	Eff Yr Blt	RMV	Quantity
No accessory data available					

SKETCH/AREA TABLE ADDENDUM

SUBJECT INFO

File No.: 532928 Parcel No.: 083W25B 01100
 Property Address: 6935 BATTLE CREEK RD SE
 City: SALEM County: State: OR ZipCode: 97317
 Owner:
 Client: Client Address:
 Appraiser Name: Inspection Date:

SKETCH

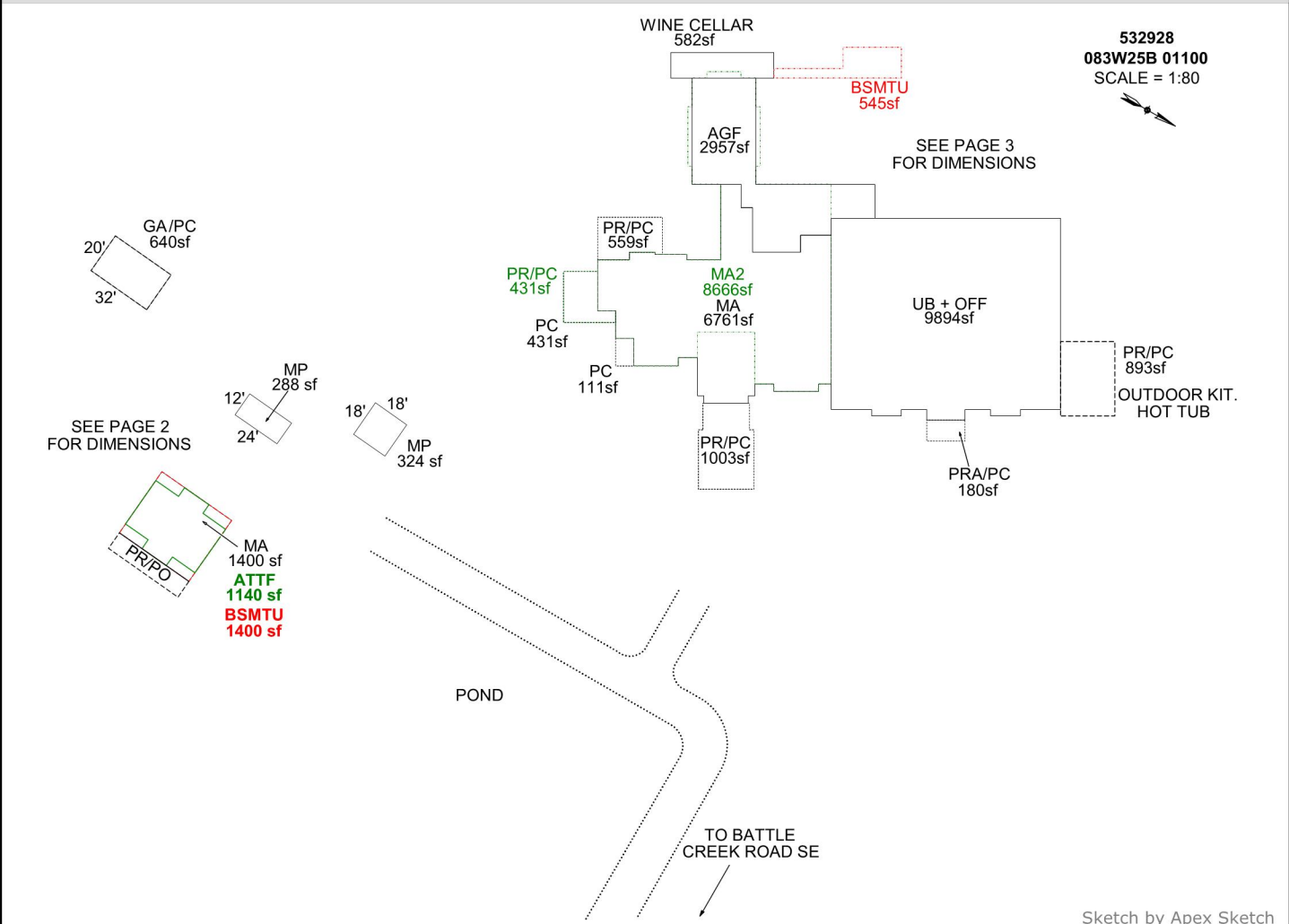

Sketch by Apex Sketch

AREA CALCULATIONS SUMMARY

Code	Description	Factor	Net Size	Perimeter	Net Totals
GBA1	MP	1.0	288.0	72.0	
	MP	1.0	324.0	72.0	
	UB + OFF	1.0	9894.0	418.0	
	WINE CELLAR	1.0	582.0	121.0	
GLA1	GA	1.0	640.0	104.0	11728.0
	MA	1.0	1400.0	150.0	
	ATTF	1.0	1140.0	150.0	
GLA2	MA	1.0	6760.5	464.0	9300.5
	MA2	1.0	8665.5	595.0	8665.5
BSMT	BSMTU	1.0	1400.0	150.0	
	BSMTU	1.0	545.0	149.0	1945.0
GAR	AGF	1.0	2956.5	336.0	2956.5
P/P	PR/PC	1.0	892.5	121.0	
	PR/PC	1.0	559.3	103.0	
	PRA/PC	1.0	180.0	56.0	
	PR/PC	1.0	430.8	97.0	
	5 addl items				
	Net LIVABLE	cnt	4 (rounded)		17,966
	Net BUILDING	cnt	5 (rounded)		11,728

COMMENT TABLE 1

UPDATED BY JRONDEMA 3/26/19
 UPDATED BY CJURAN 12/22/2021
 UPDATED BY CJURAN 08/03/2022 555-22-009782
 UPDATED BY CJURAN 10/05/2022 555-22-007384
 UPDATED BY CJURAN 10/02/2023 23-000101 GAZ

COMMENT TABLE 2

#35 12/05/20218
 12/04/2019
 #10 CL 02/24/2021

COMMENT TABLE 3

TAGS
 RE-TAG
 -

SKETCH/AREA TABLE ADDENDUM

SUBJECT INFO

File No.: 532928 Parcel No.: 083W25B 01100
 Property Address: 6935 BATTLE CREEK RD SE
 City: SALEM County: State: OR ZipCode: 97317
 Owner:
 Client: Client Address:
 Appraiser Name: Inspection Date:

SKETCH

532928

083W25B 01100

SCALE = 1:20



SEE PAGE ONE FOR ALL BUILDINGS

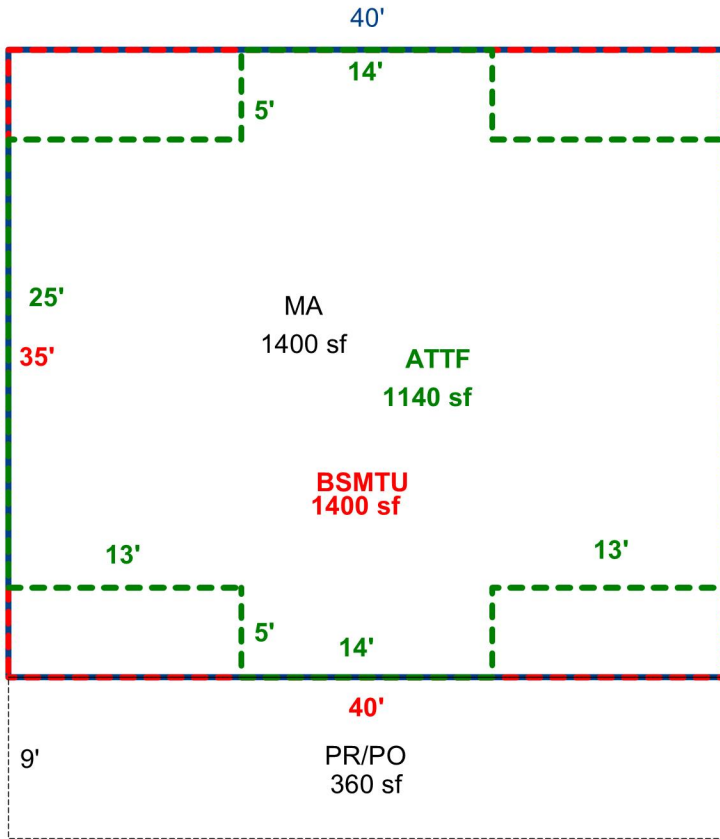

Sketch by Apex Sketch

AREA CALCULATIONS SUMMARY

Code	Description	Factor	Net Size	Perimeter	Net Totals
GLA1	MA	1.0	1400.0	150.0	
	ATTF	1.0	1140.0	150.0	2540.0
BSMT	BSMTU	1.0	1400.0	150.0	1400.0
P/P	PR/PO	1.0	360.0	98.0	360.0

COMMENT TABLE 1

UPDATED BY JRONDEMA 3/26/19
 UPDATED BY CJURAN 12/22/2021
 UPDATED BY CJURAN 08/03/2022 555-22-009782
 UPDATED BY CJURAN 10/05/2022 555-22-007384
 UPDATED BY CJURAN 10/02/2023 23-000101 GAZ

COMMENT TABLE 2

#35 12/05/20218
 12/04/2019
 #10 CL 02/24/2021

COMMENT TABLE 3

TAGS
 RE-TAG
 -

Net LIVABLE cnt 2 (rounded) 2,540

SKETCH/AREA TABLE ADDENDUM

SUBJECT INFO

File No.: 532928 Parcel No.: 083W25B 01100
 Property Address: 6935 BATTLE CREEK RD SE
 City: SALEM County: State: OR ZipCode: 97317
 Owner:
 Client: Client Address:
 Appraiser Name: Inspection Date:

SKETCH

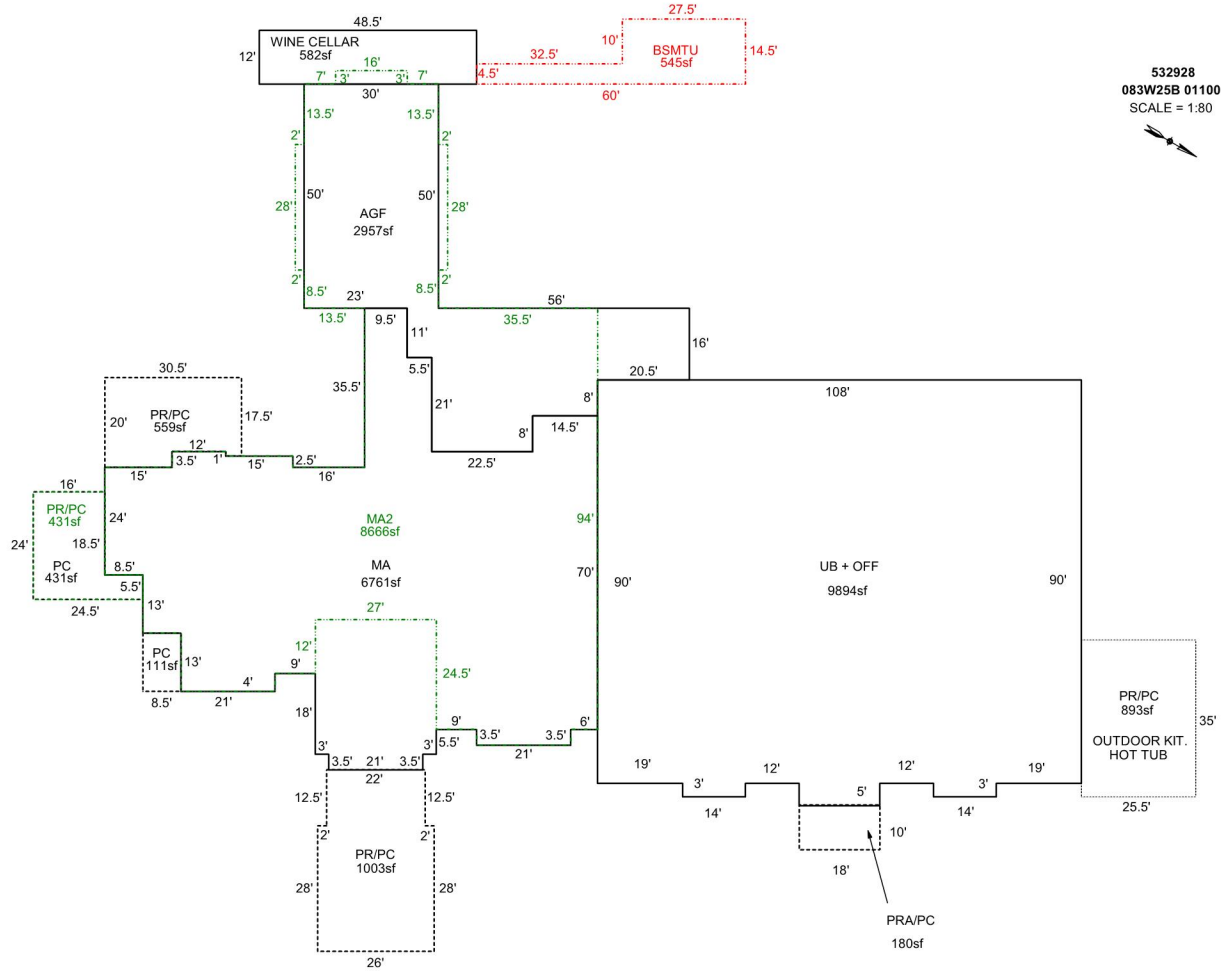

532928
083W25B 01100
SCALE = 1:80



Sketch by Apex Sketch

AREA CALCULATIONS SUMMARY

Code	Description	Factor	Net Size	Perimeter	Net Totals
GBA1	UB + OFF	1.0	9894.0	418.0	
	WINE CELLAR	1.0	582.0	121.0	10476.0
GLA1	MA	1.0	6760.5	464.0	6760.5
GLA2	MA2	1.0	8665.5	595.0	8665.5
BSMT	BSMTU	1.0	545.0	149.0	545.0
GAR	AGF	1.0	2956.5	336.0	2956.5
P/P	PRA/PC	1.0	180.0	56.0	
	PR/PC	1.0	892.5	121.0	
	PR/PC	1.0	1003.0	133.0	
	PC	1.0	110.5	43.0	
	PC	1.0	430.8	97.0	
	PR/PC	1.0	430.8	97.0	
	PR/PC	1.0	559.3	103.0	3606.8
	Net LIVABLE	cnt	2 (rounded)		15,426
	Net BUILDING	cnt	2 (rounded)		10,476

COMMENT TABLE 1

UPDATED BY JRONDEMA 3/26/19
 UPDATED BY CJURAN 12/22/2021
 UPDATED BY CJURAN 08/03/2022 555-22-009782
 UPDATED BY CJURAN 10/05/2022 555-22-007384
 UPDATED BY CJURAN 10/02/2023 23-000101 GAZ

COMMENT TABLE 2

#35 12/05/20218
 12/04/2019
 #10 CL 02/24/2021

COMMENT TABLE 3

TAGS
 RE-TAG
 -



R32928 ART STUDIO 12.05.18



R32928 MA E SIDE 12.05.18



R32928 MP 12x24 12.05.18



R32928 MP 18x18 12.05.18



R32928 UB FRONT 12.05.18



R32928 UB N SIDE 12.05.18



R32928 UB REAR MID 12.05.18



R32928 UB REAR 12.05.18



R32928 UB SHORTER SIDE 12.05.18



R32928 UB SIDE 12.05.18



R32928 ART STUDIO 12.05.18



R32928 MA E SIDE 12.05.18



R32928 MP 12x24 12.05.18



R32928 MP 18x18 12.05.18



R32928 UB FRONT 12.05.18



R32928 UB N SIDE 12.05.18



R32928 UB REAR MID 12.05.18



R32928 UB REAR 12.05.18



R32928 UB SHORTER SIDE 12.05.18



R32928 UB SIDE 12.05.18



R32928 UGB FRONT 12.05.18



R32928 UGB N SIDE 12.05.18



R32928 UGB REAR MID 12.05.18



R32928 UGB REAR 12.05.18



R32928 UGB SHORTER SIDE 12.05.18



R32928 UGB SIDE 12.05.18



R32928 UB- (3)
2021-02-24 L2



R32928 UB- (5)
2021-02-24 L2



R32928 UB- (9)
2021-02-24 L2



R32928 UB- (2)
2021-02-24 L2



R32928 UB- (5)
2021-02-24 L2



R32928 UB- (8)
2021-02-24 L2



R32928 UB- (1)
2021-02-24 L2



R32928 UB- (4)
2021-02-24 L2



R32928 UB- (7)
2021-02-24 L2



R32928 UB- (11)
2021-02-24 L2



R32928 UB- (10)
2021-02-24 L2











Acct ID: 532928 MTL: 083W25B001100 Date: **12-18-23** Appr: **WW** Prop Class: 501 RMV Prop Class: 501
 Situs: 6935 BATTLE CREEK RD SE SALEM OR 97317 **1-25** MaSaNh: 06 06 000 Unit: 56463 Year: 2023
 Last Date Appraised: 12/30/2022 Appraiser: WENDY WILLIAMS Retag: **Y** N Tag info: 2024 - Tags/Permit (Completion)
 Owner: **BC SANCTUARY LLC** Roll Type: R
 Cycle: **Tag** Sales Verification Other: _____ Inspection level: 1 2 **3** 4 LCB TTO INSP **12-18-23 gate** AV: 691680
 RMV Land: 534180 RMV Imp: 1096500 RMV Total: 1630680 MAV: 691680 MSAV: 0 **12-22-23 letter** SAV: 0
 Comment: 23-24: L3 12.30.22 GRH **1-25-24 gate**
 22-23: LEVEL 2 ML 11.10.21 // 22-23 L4 6/10/22 CLUKE **1-29-24**

No inspections, no response
Retag 25

8/21/23 nothing yet spw planning - check end of year and retag if still nothing permit wont expire until 7/2024

Notations

No notation data available.
23-000101 Pond Pavilion
22-007384 Covered patio
OSDs 01-009784 6 bed 14 bath

1st: 6761 sf
 bth-4, fp-3, kit,
 outdoor kit,
 bbq, roof, hvac
 +
 2nd: 8881 sf,
 bath-7, bth-4,
 bath+2
 AGF: 2957
 BSMTGU: 582

Count	Code	Description	RMV	Code Area	Exception
2	MKTG	OSD - GOOD	55000	92590	0

Land

Site: 1 Code Area: 92590 Size: 5.77 Acres Use Code: 005 Zone: REST SAV Use: _____ Exception: 0
 Class: 4HD Value Source: Rural Restrictive Description: FOUR HILL DRY RMV: 148760 Exception: Y N
 Adjustment(s): H2OFR, GSOIL, IRR, FSOIL, GSOIL Fire Patrol: _____ Description: _____
 Comments: 22-23 CHANGED WATER ADJUSTMENT TO FAIR
 99-2000: DISQ FARM USE /00-01; REAPPRAISAL

Site: 2 Code Area: 92590 Size: 3.50 Acres Use Code: 005 Zone: REST SAV Use: _____ Exception: 0
 Class: 4HI Value Source: Rural Restrictive Description: FOUR HILL IRR RMV: 75640 Exception: Y N
 Adjustment(s): H2OFR, GSOIL, IRR, FSOIL, GSOIL Fire Patrol: _____ Description: _____
 Comments: _____

Site: 4 Code Area: 92590 Size: 3.35 Acres Use Code: 005 Zone: REST SAV Use: _____ Exception: 0
 Class: 6H Value Source: Rural Restrictive Description: SIX HILL RMV: 65500 Exception: Y N
 Adjustment(s): H2OFR, GSOIL, IRR, FSOIL, GSOIL Fire Patrol: _____ Description: _____
 Comments: _____

Site: 5 Code Area: 92590 Size: 7.98 Acres Use Code: 005 Zone: REST SAV Use: _____ Exception: 0
 Class: 2HD Value Source: Rural Restrictive Description: TWO HILL DRY RMV: 180680 Exception: Y N
 Adjustment(s): H2OFR, GSOIL, IRR, FSOIL, GSOIL Fire Patrol: _____ Description: _____
 Comments: _____

Site: 6 Code Area: 05590 Size: 0.38 Acres Use Code: 005 Zone: REST SAV Use: _____ Exception: 0
 Class: 2HD Value Source: Rural Restrictive Description: TWO HILL DRY RMV: 8600 Exception: Y N
 Adjustment(s): H2OFR, GSOIL, IRR, FSOIL, GSOIL Fire Patrol: _____ Description: _____
 Comments: 99-2000: DISQ FARMUSE /00-01; REAPPRAISAL

Improvements - Residence / Manufactured Structures

Bldg: 1 Code Area: 92590 Stat Class: 144 Year Blt: 1922 Eff Year Blt: 1977 Sq.Ft: 2540 % Complete: 100
 Desc: Multi Story above grade with basement Dimensions: _____ RMV: 443470
 Func Obsc: 100 Econ %: 100 Other %: 100 Exception: 0 Adjust: _____ Adjust RMV: 0

Floors

Type	Class	Display Group	Floor Size	Beds	Baths	Yr Blt	Eff Yr Blt	Inventory	Exception
First Floor	4	Finished	1400	1	FB-1/ HB-1	1922	1977	BATH - 1, BTH - 1, KIT-, ROOF, HVAC+, FP	Exception: Y N
Attic	4	Finished	1140	3	FB-1	1922	1977	BATH - 1, HVAC+	Exception: Y N
Basement	4	Unfinished	1400	0	0	1922	1977		Exception: Y N

Accessories

Description	Class	Size SqFt	Eff Yr Blt	RMV	Quantity	Exception
YARD IMPROVEMENTS AVERAGE	4	0	1977	22113	1	Exception: Y N

Improvements - Accessory Buildings

Bldg: 2 Code Area: 92590 Stat Class: 352 Year Blt: 2005 Eff Year Blt: 2016 Sq.Ft: 9893 % Complete: 100
 Desc: Utility Building (UB) Dimensions: _____ RMV: 627130
 Func Obsc: 100 Econ %: 100 Other %: 100 Exception: 0 Adjust: _____ Adjust RMV: 0

Floors

Type	Class	Display Group	Floor Size	Beds	Baths	Yr Blt	Eff Yr Blt	Inventory	Exception
Utility Building	6	Finished	9893	0	FB-2	2005	2016	BATH - 2, AVG	Exception: Y N

Accessories

Description	Class	Size SqFt	Eff Yr Blt	RMV	Quantity
FINISHED OFFICE IN A FARM BUILDING	6	9893	2016	287144	0

Exception: Y N

Bldg: 3	Code Area: 92590	Stat Class: 341	Year Blt: 2007	Eff Year Blt: 2007	Sq.Ft: 648	% Complete: 100
Desc: Multi Purpose Shed (MP)				Dimensions: 18x18		RMV: 20590
Func Obsc: 100	Econ %: 100	Other %: 100	Exception: 0		Adjust:	Adjust RMV: 0

Floors

Type	Class	Display Group	Floor Size	Beds	Baths	Yr Blt	Eff Yr Blt	Inventory	Exception: Y N
Finished Office	6	Finished	324	0	0	2008	2008	FAIR	Y N
Multi-Purpose Bldg	6	Finished	324	0	0	2007	2007		Y N

check MP excel

Accessories

Description	Class	Size SqFt	Eff Yr Blt	RMV	Quantity
No accessory data available					

Bldg: 4	Code Area: 92590	Stat Class: 341	Year Blt: 2007	Eff Year Blt: 2007	Sq.Ft: 288	% Complete: 100
Desc: Multi Purpose Shed (MP)				Dimensions: 12x24		RMV: 5310
Func Obsc: 100	Econ %: 100	Other %: 100	Exception: 0		Adjust:	Adjust RMV: 0

Floors

Type	Class	Display Group	Floor Size	Beds	Baths	Yr Blt	Eff Yr Blt	Inventory	Exception: Y N
Multi-Purpose Bldg	4	Finished	288	0	0	2007	2007	FAIR	Y N

Accessories

Description	Class	Size SqFt	Eff Yr Blt	RMV	Quantity
No accessory data available					



SKETCH/AREA TABLE ADDENDUM

SUBJECT INFO

File No.: 532928 Parcel No.: 083W25B 01100
 Property Address: 6935 BATTLE CREEK RD SE
 City: SALEM County: State: OR ZipCode: 97317
 Owner:
 Client: Client Address:
 Appraiser Name: Inspection Date:

SKETCH

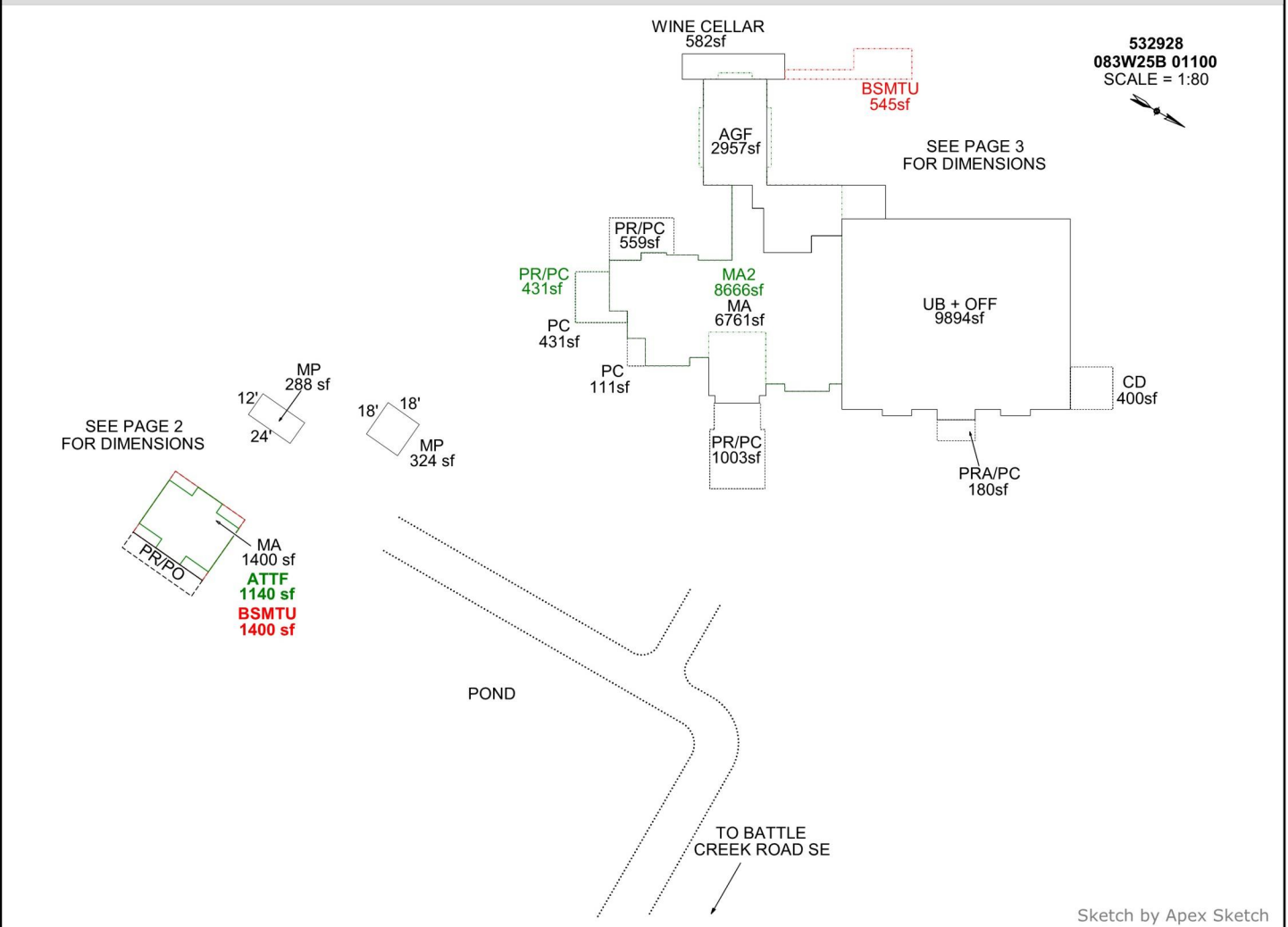

AREA CALCULATIONS SUMMARY

Code	Description	Factor	Net Size	Perimeter	Net Totals
GBA1	MP	1.0	288.0	72.0	
	MP	1.0	324.0	72.0	
	UB + OFF	1.0	9894.0	418.0	
	WINE CELLAR	1.0	582.0	121.0	11088.0
GLA1	MA	1.0	1400.0	150.0	
	MA	1.0	6760.5	464.0	
	ATTF	1.0	1140.0	150.0	9300.5
GLA2	MA2	1.0	8665.5	595.0	8665.5
BSMT	BSMTU	1.0	545.0	149.0	
	BSMTU	1.0	1400.0	150.0	1945.0
GAR	AGF	1.0	2956.5	336.0	2956.5
	P/P	PR/PO	1.0	360.0	98.0
	PRA/PC	1.0	180.0	56.0	
	PC	1.0	430.8	97.0	
	PR/PC	1.0	430.8	97.0	
	PR/PC	1.0	1003.0	133.0	
	3 addl items				
	Net LIVABLE	cnt	4 (rounded)		17,966
	Net BUILDING	cnt	4 (rounded)		11,088

COMMENT TABLE 1

UPDATED BY JRONDEMA 3/26/19
 UPDATED BY CJURAN 12/22/2021
 UPDATED BY CJURAN 08/03/2022 555-22-009782

COMMENT TABLE 2

#35 12/05/20218
 12/04/2019
 #10 CL 02/24/2021

COMMENT TABLE 3

TAGS
 RE-TAG
 -

SKETCH/AREA TABLE ADDENDUM

SUBJECT INFO

File No.: 532928 Parcel No.: 083W25B 01100
 Property Address: 6935 BATTLE CREEK RD SE
 City: SALEM County: State: OR ZipCode: 97317
 Owner:
 Client: Client Address:
 Appraiser Name: Inspection Date:

SKETCH

532928

083W25B 01100

SCALE = 1:20



SEE PAGE ONE FOR ALL BUILDINGS

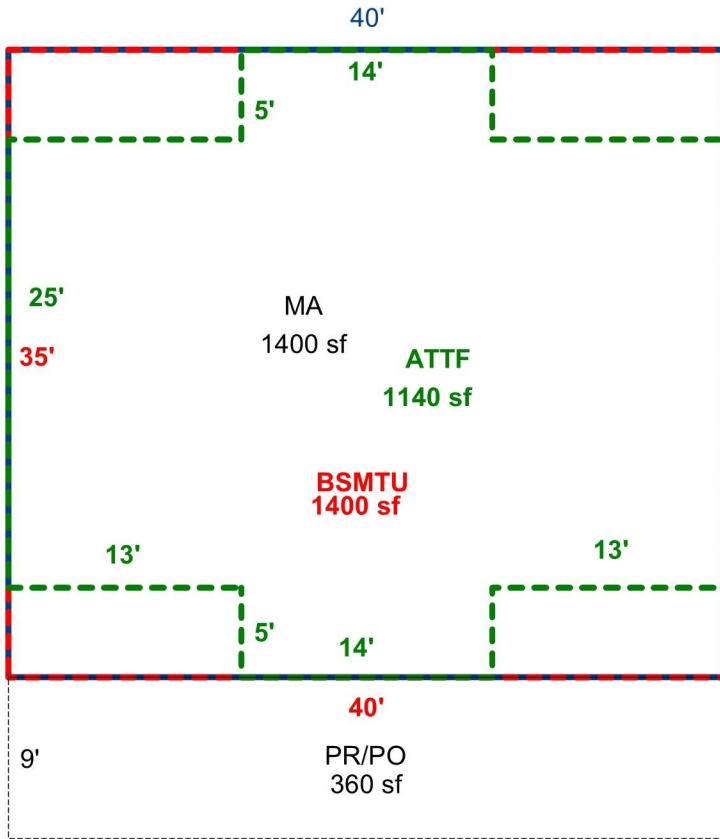

Sketch by Apex Sketch

AREA CALCULATIONS SUMMARY

Code	Description	Factor	Net Size	Perimeter	Net Totals
GLA1	MA	1.0	1400.0	150.0	
	ATTF	1.0	1140.0	150.0	2540.0
BSMT	BSMTU	1.0	1400.0	150.0	1400.0
P/P	PR/PO	1.0	360.0	98.0	360.0

COMMENT TABLE 1

UPDATED BY JRONDEMA 3/26/19
 UPDATED BY CJURAN 12/22/2021
 UPDATED BY CJURAN 08/03/2022 555-22-009782

COMMENT TABLE 2

#35 12/05/20218
 12/04/2019
 #10 CL 02/24/2021

COMMENT TABLE 3

TAGS
 RE-TAG
 -

Net LIVABLE cnt 2 (rounded) 2,540

SKETCH/AREA TABLE ADDENDUM

SUBJECT INFO

File No.: 532928 Parcel No.: 083W25B 01100
 Property Address: 6935 BATTLE CREEK RD SE
 City: SALEM County: State: OR ZipCode: 97317
 Owner:
 Client: Client Address:
 Appraiser Name: Inspection Date:

SKETCH

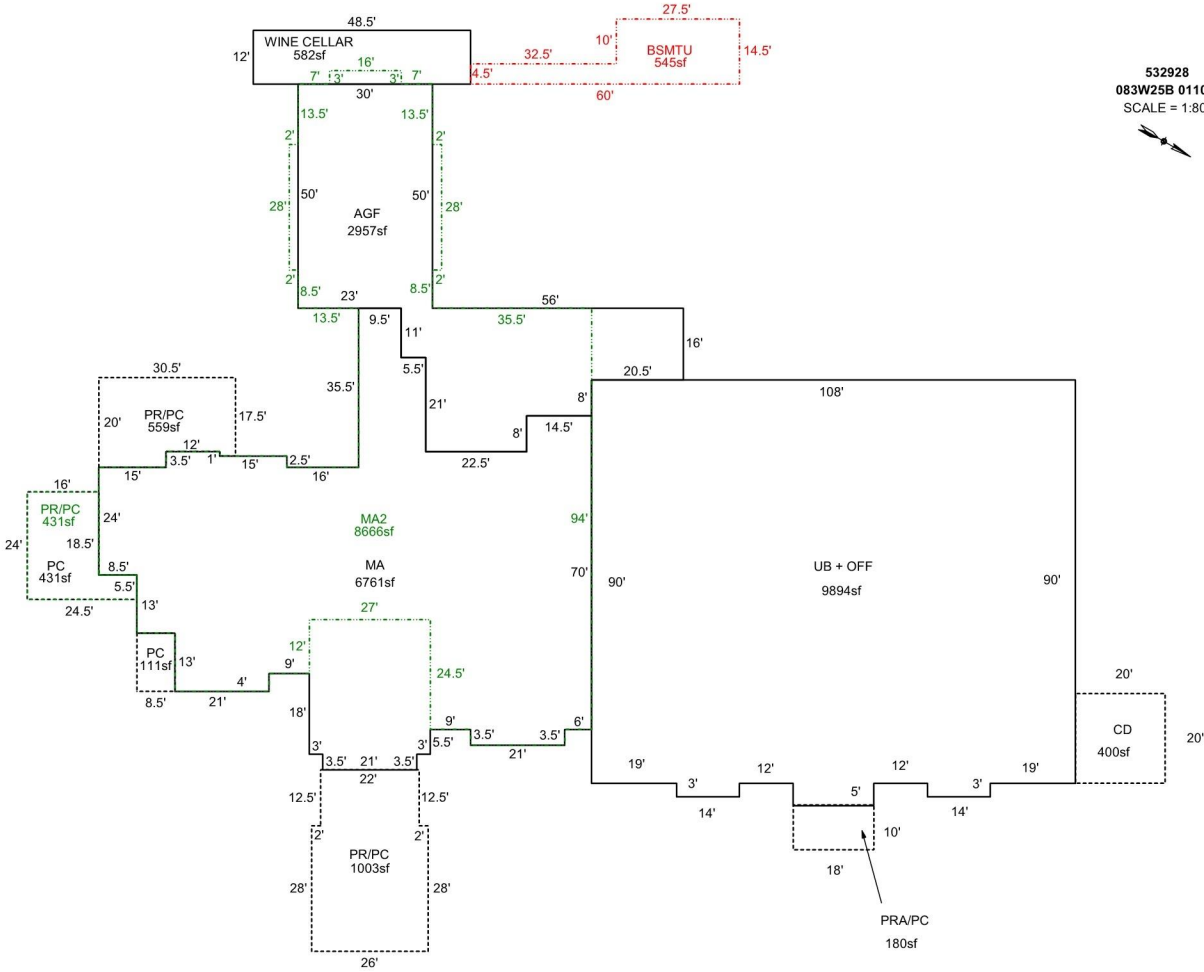

AREA CALCULATIONS SUMMARY

Code	Description	Factor	Net Size	Perimeter	Net Totals
GBA1	UB + OFF	1.0	9894.0	418.0	
	WINE CELLAR	1.0	582.0	121.0	10476.0
GLA1	MA	1.0	6760.5	464.0	6760.5
GLA2	MA2	1.0	8665.5	595.0	8665.5
BSMT	BSMTU	1.0	545.0	149.0	545.0
GAR	AGF	1.0	2956.5	336.0	2956.5
P/P	PRA/PC	1.0	180.0	56.0	
	CD	1.0	400.0	80.0	
	PR/PC	1.0	1003.0	133.0	
	PC	1.0	110.5	43.0	
	PC	1.0	430.8	97.0	
	PR/PC	1.0	430.8	97.0	
	PR/PC	1.0	559.3	103.0	3114.3
	Net LIVABLE	cnt	2 (rounded)		15,426
	Net BUILDING	cnt	2 (rounded)		10,476

COMMENT TABLE 1

UPDATED BY JRONDEMA 3/26/19
 UPDATED BY CJURAN 12/22/2021
 UPDATED BY CJURAN 08/03/2022 555-22-009782

COMMENT TABLE 2

#35 12/05/20218
 12/04/2019
 #10 CL 02/24/2021

COMMENT TABLE 3

TAGS
 RE-TAG
 -

SKETCH/AREA TABLE ADDENDUM

SUBJECT INFO

File No.: 532928 Parcel No.: 083W25B 01100
 Property Address: 6935 BATTLE CREEK RD SE
 City: SALEM County: State: OR ZipCode: 97317
 Owner:
 Client: Client Address:
 Appraiser Name: Inspection Date:

SKETCH

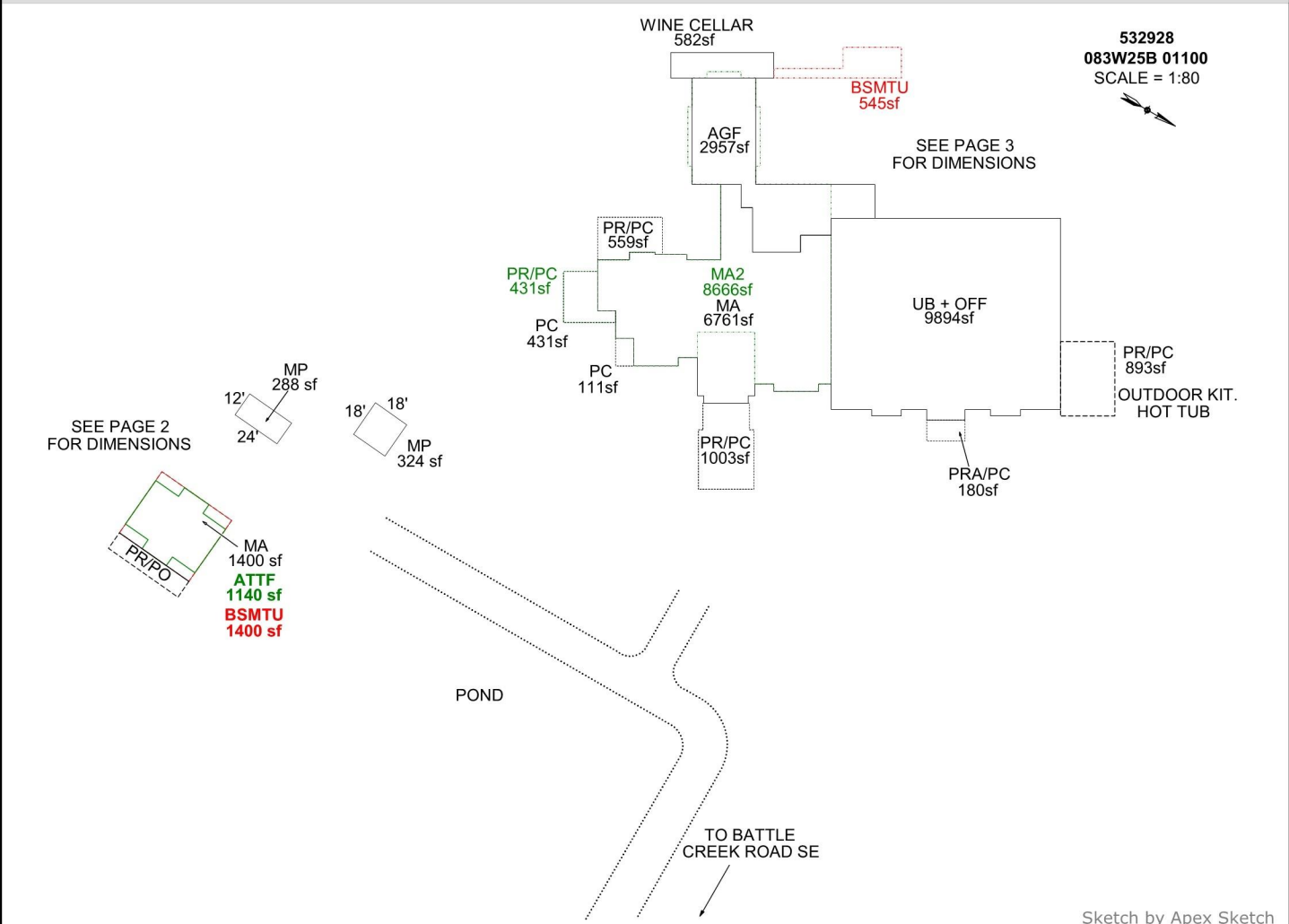

Sketch by Apex Sketch

AREA CALCULATIONS SUMMARY

COMMENT TABLE 1

Code	Description	Factor	Net Size	Perimeter	Net Totals
GBA1	MP	1.0	288.0	72.0	
	MP	1.0	324.0	72.0	
	UB + OFF	1.0	9894.0	418.0	
	WINE CELLAR	1.0	582.0	121.0	11088.0
GLA1	MA	1.0	1400.0	150.0	
	ATTF	1.0	1140.0	150.0	
	MA	1.0	6760.5	464.0	9300.5
GLA2	MA2	1.0	8665.5	595.0	8665.5
	BSMTU	1.0	545.0	149.0	
BSMT	BSMTU	1.0	1400.0	150.0	1945.0
	AGF	1.0	2956.5	336.0	2956.5
GAR	PRA/PC	1.0	180.0	56.0	
	PC	1.0	430.8	97.0	
P/P	PR/PC	1.0	430.8	97.0	
	PR/PC	1.0	1003.0	133.0	
	PR/PO	1.0	360.0	98.0	
	3 addl items				
	Net LIVABLE	cnt	4 (rounded)		17,966
	Net BUILDING	cnt	4 (rounded)		11,088

UPDATED BY JRONDEMA 3/26/19
 UPDATED BY CJURAN 12/22/2021
 UPDATED BY CJURAN 08/03/2022 555-22-009782
 UPDATED BY CJURAN 10/05/2022 555-22-007384

COMMENT TABLE 2

COMMENT TABLE 3

#35 12/05/20218
 12/04/2019
 #10 CL 02/24/2021

TAGS
 RE-TAG
 -

SKETCH/AREA TABLE ADDENDUM

SUBJECT INFO

File No.: 532928 Parcel No.: 083W25B 01100
 Property Address: 6935 BATTLE CREEK RD SE
 City: SALEM County: State: OR ZipCode: 97317
 Owner:
 Client: Client Address:
 Appraiser Name: Inspection Date:

SKETCH

532928

083W25B 01100

SCALE = 1:20



SEE PAGE ONE FOR ALL BUILDINGS

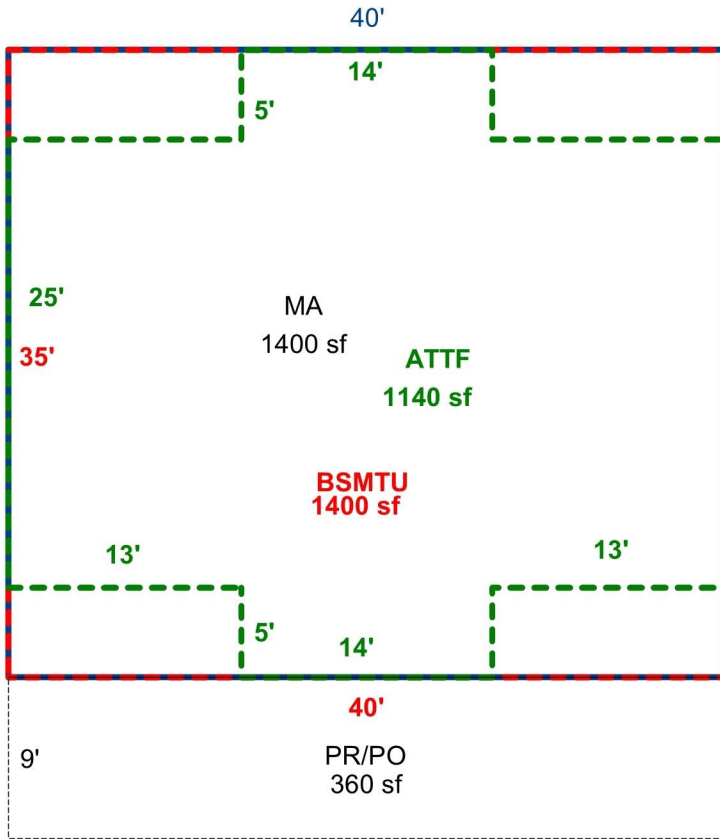

Sketch by Apex Sketch

AREA CALCULATIONS SUMMARY

Code	Description	Factor	Net Size	Perimeter	Net Totals
GLA1	MA	1.0	1400.0	150.0	
	ATTF	1.0	1140.0	150.0	2540.0
BSMT	BSMTU	1.0	1400.0	150.0	1400.0
P/P	PR/PO	1.0	360.0	98.0	360.0

COMMENT TABLE 1

UPDATED BY JRONDEMA 3/26/19
 UPDATED BY CJURAN 12/22/2021
 UPDATED BY CJURAN 08/03/2022 555-22-009782
 UPDATED BY CJURAN 10/05/2022 555-22-007384

COMMENT TABLE 2

#35 12/05/20218
 12/04/2019
 #10 CL 02/24/2021

COMMENT TABLE 3

TAGS
 RE-TAG
 -

Net LIVABLE cnt 2 (rounded) 2,540

SKETCH/AREA TABLE ADDENDUM

SUBJECT INFO

File No.: 532928 Parcel No.: 083W25B 01100
 Property Address: 6935 BATTLE CREEK RD SE
 City: SALEM County: State: OR ZipCode: 97317
 Owner:
 Client: Client Address:
 Appraiser Name: Inspection Date:

SKETCH

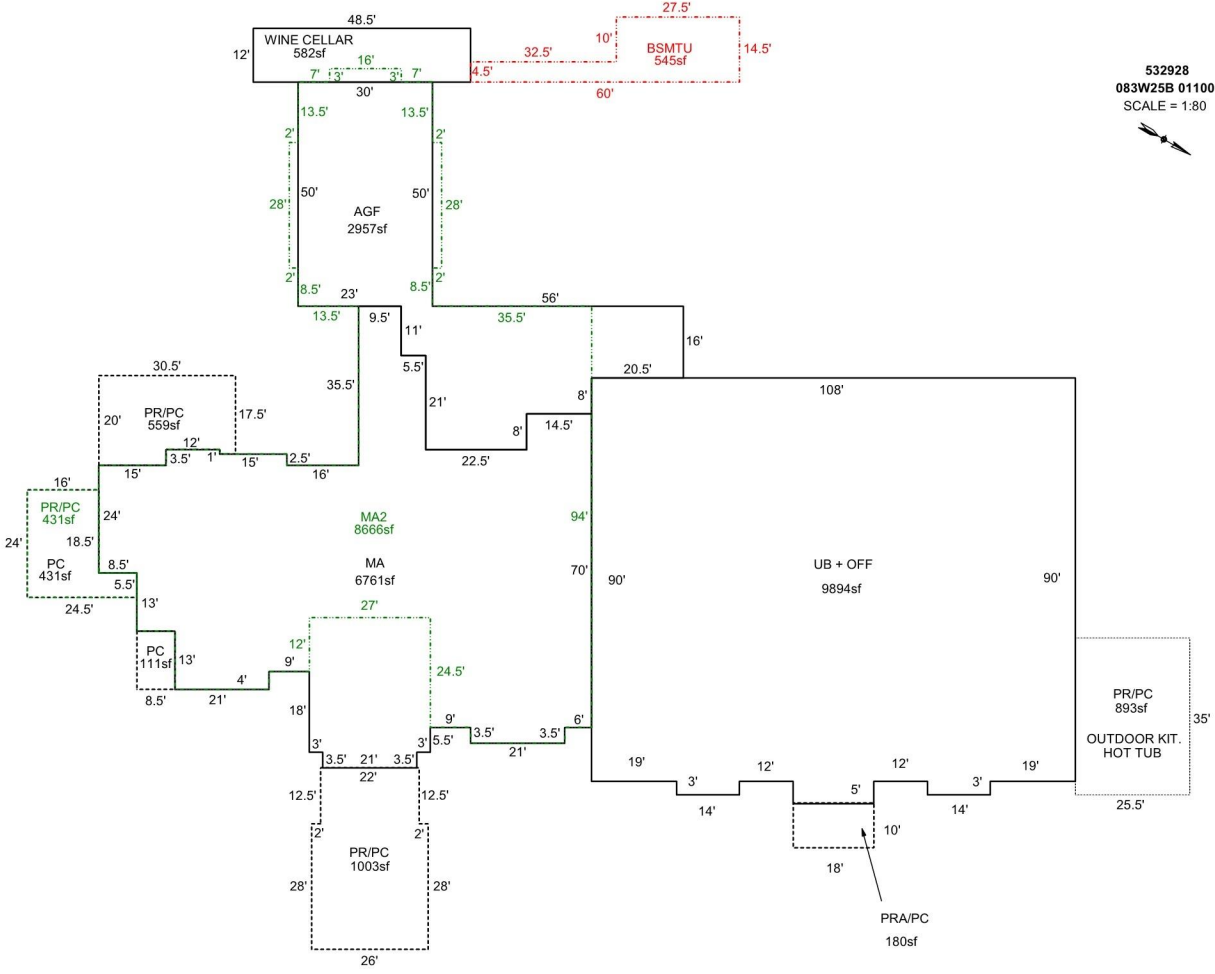

AREA CALCULATIONS SUMMARY

Code	Description	Factor	Net Size	Perimeter	Net Totals
GBA1	UB + OFF	1.0	9894.0	418.0	
	WINE CELLAR	1.0	582.0	121.0	10476.0
GLA1	MA	1.0	6760.5	464.0	6760.5
GLA2	MA2	1.0	8665.5	595.0	8665.5
BSMT	BSMTU	1.0	545.0	149.0	545.0
GAR	AGF	1.0	2956.5	336.0	2956.5
P/P	PRA/PC	1.0	180.0	56.0	
	PR/PC	1.0	892.5	121.0	
	PR/PC	1.0	1003.0	133.0	
	PC	1.0	110.5	43.0	
	PC	1.0	430.8	97.0	
	PR/PC	1.0	430.8	97.0	
	PR/PC	1.0	559.3	103.0	3606.8
	Net LIVABLE	cnt	2 (rounded)		15,426
	Net BUILDING	cnt	2 (rounded)		10,476

COMMENT TABLE 1

UPDATED BY JRONDEMA 3/26/19
 UPDATED BY CJURAN 12/22/2021
 UPDATED BY CJURAN 08/03/2022 555-22-009782
 UPDATED BY CJURAN 10/05/2022 555-22-007384

COMMENT TABLE 2

#35 12/05/20218
 12/04/2019
 #10 CL 02/24/2021

COMMENT TABLE 3

TAGS
 RE-TAG
 -

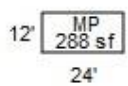
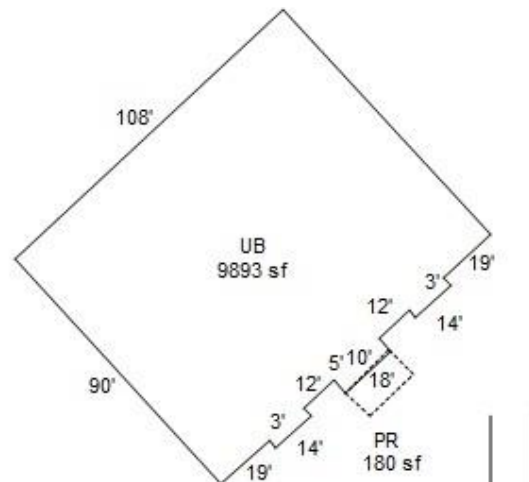

"SEE PAGE TWO FOR HOME DIMENSIONS"

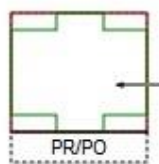

- MA
1400 sf
- ATTF
1140 sf
- BSMTU
1400 sf

POND

GRAVEL DRIVE

083W25B 01100

R32928

SEE PAGE TWO FOR HOME DIMENSIONS

SCALE=1/75

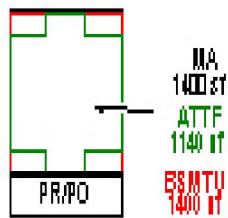
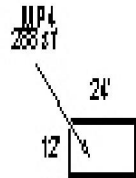
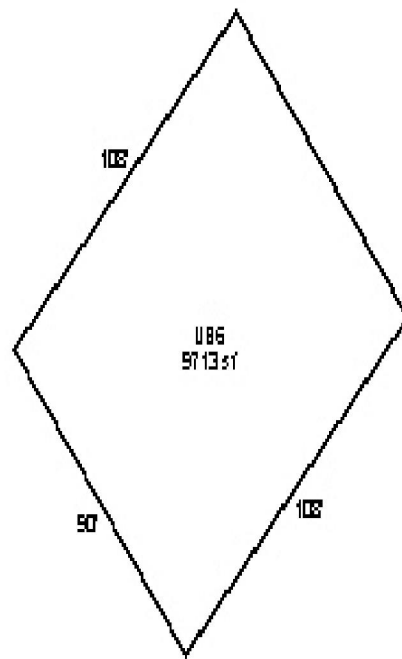

POND

GRAVEL DRIVE



"SEE PAGE ONE FOR ALL BUILDINGS"

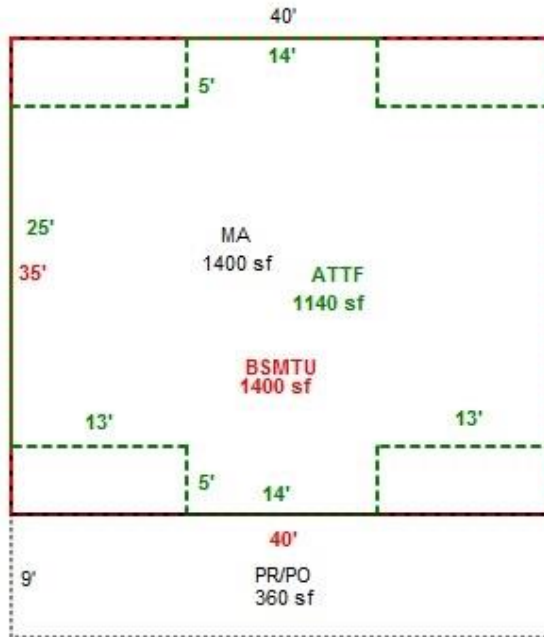

083W25B 01100

R32928

SEE PAGE ONE FOR ALL BUILDINGS

SCALE=1/20

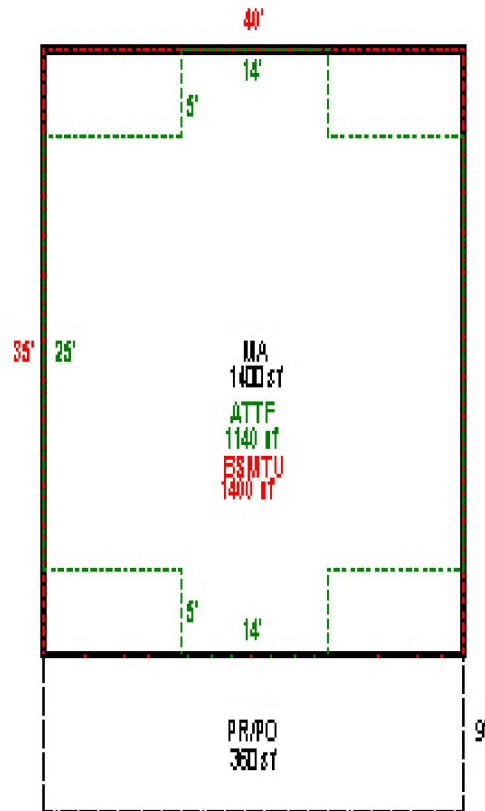

SKETCH/AREA TABLE ADDENDUM

SUBJECT INFO

File No.: 532928 Parcel No.: 083W25B 01100
 Property Address: 6935 BATTLE CREEK RD SE
 City: SALEM County: State: OR ZipCode: 97317
 Owner:
 Client: Client Address:
 Appraiser Name: Inspection Date:

SKETCH

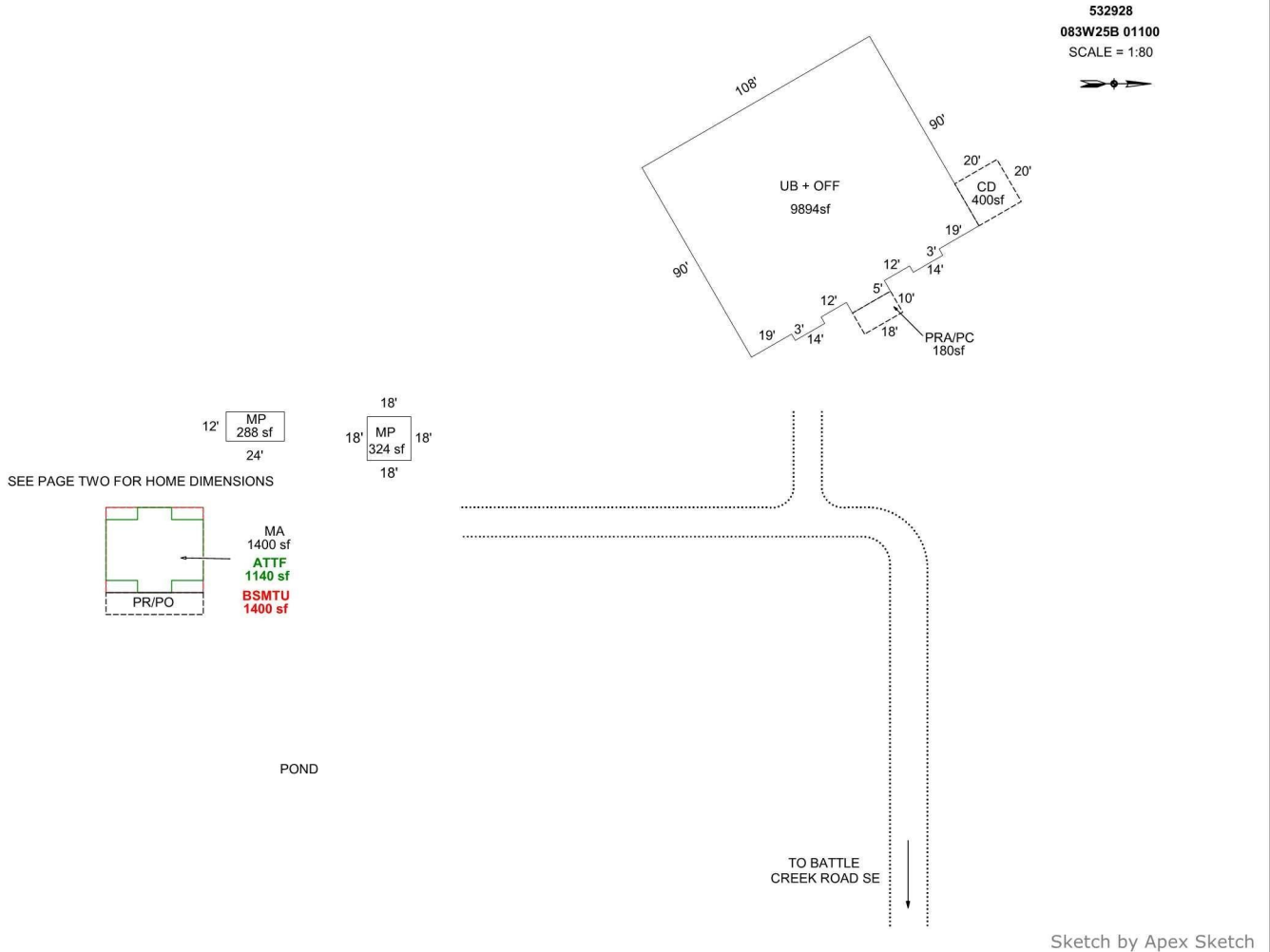

AREA CALCULATIONS SUMMARY

Code	Description	Factor	Net Size	Perimeter	Net Totals
GBA1	MP	1.0	288.0	72.0	
	MP	1.0	324.0	72.0	
	UB + OFF	1.0	9894.0	418.0	10506.0
GLA1	MA	1.0	1400.0	150.0	
	ATTF	1.0	1140.0	150.0	2540.0
BSMT	BSMTU	1.0	1400.0	150.0	1400.0
P/P	PR/PO	1.0	360.0	98.0	
	CD	1.0	400.0	80.0	
	PRA/PC	1.0	180.0	56.0	940.0
	Net LIVABLE	cnt	2 (rounded)		2,540
	Net BUILDING	cnt	3 (rounded)		10,506

COMMENT TABLE 1

UPDATED BY JRONDEMA 3/26/19
 UPDATED BY CJURAN 12/22/2021

COMMENT TABLE 2

#35 12/05/20218
 12/04/2019
 #10 CL 02/24/2021

COMMENT TABLE 3

TAGS
 RE-TAG
 -

SKETCH/AREA TABLE ADDENDUM

SUBJECT INFO

File No.: 532928 Parcel No.: 083W25B 01100
 Property Address: 6935 BATTLE CREEK RD SE
 City: SALEM County: State: OR ZipCode: 97317
 Owner:
 Client: Client Address:
 Appraiser Name: Inspection Date:

SKETCH

532928

083W25B 01100

SCALE = 1:20



SEE PAGE ONE FOR ALL BUILDINGS

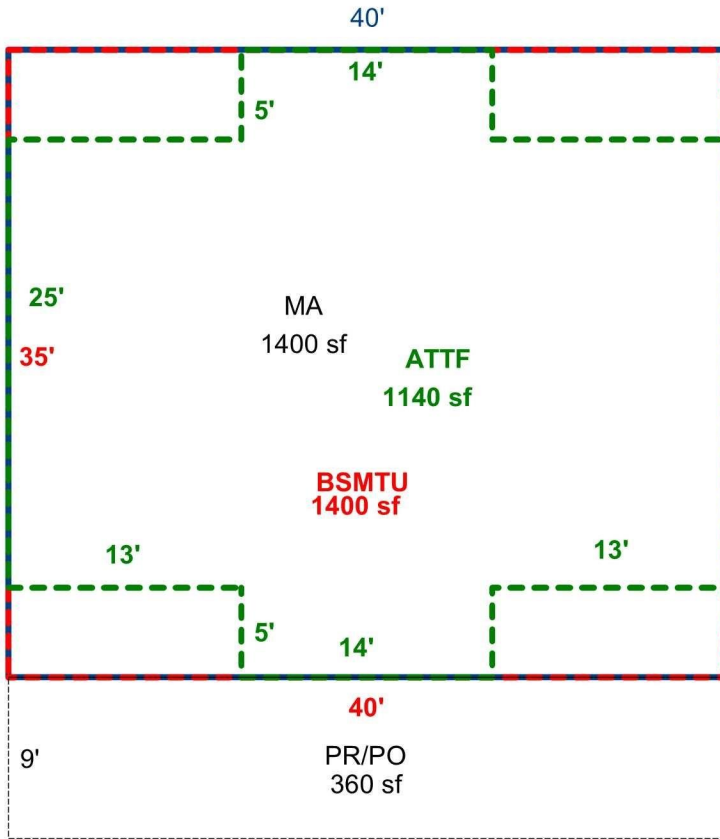

Sketch by Apex Sketch

AREA CALCULATIONS SUMMARY

Code	Description	Factor	Net Size	Perimeter	Net Totals
GLA1	MA	1.0	1400.0	150.0	
	ATTF	1.0	1140.0	150.0	2540.0
BSMT	BSMTU	1.0	1400.0	150.0	1400.0
P/P	PR/PO	1.0	360.0	98.0	360.0

COMMENT TABLE 1

UPDATED BY JRONDEMA 3/26/19
 UPDATED BY CJURAN 12/22/2021

COMMENT TABLE 2

#35 12/05/20218
 12/04/2019
 #10 CL 02/24/2021

COMMENT TABLE 3

TAGS
 RE-TAG
 -

Net LIVABLE cnt 2 (rounded) 2,540



R32928 ART STUDIO 12.05.18



R32928 MA E SIDE 12.05.18



R32928 MP 12x24 12.05.18



R32928 MP 18x18 12.05.18



R32928 UB FRONT 12.05.18



R32928 UB N SIDE 12.05.18



R32928 UB REAR MID 12.05.18



R32928 UB REAR 12.05.18



R32928 UB SHORTER SIDE 12.05.18



R32928 UB SIDE 12.05.18



R32928 ART STUDIO 12.05.18



R32928 MA E SIDE 12.05.18



R32928 MP 12x24 12.05.18



R32928 MP 18x18 12.05.18



R32928 UB FRONT 12.05.18



R32978 UB N SIDE 12.05.18



R32928 UB REAR MID 12.05.18



R32928 UB REAR 12.05.18



R32928 UB SHORTER SIDE 12.05.18



R32928 UB SIDE 12.05.18



R32928 UGB FRONT 12.05.18



R32978 UGB N SIDE 12.05.18



R32928 UGB REAR MID 12.05.18



R32928 UGB REAR 12.05.18



R32928 UGB SHORTER SIDE 12.05.18



R32928 UGB SIDE 12.05.18



R32928 UB- (3)
2021-02-24 L2



R32928 UB- (6)
2021-02-24 L2



R32928 UB- (9)
2021-02-24 L2



R32928 UB- (2)
2021-02-24 L2



R32928 UB- (5)
2021-02-24 L2



R32928 UB- (8)
2021-02-24 L2



R32928 UB- (1)
2021-02-24 L2



R32928 UB- (4)
2021-02-24 L2



R32928 UB- (7)
2021-02-24 L2



R32928 UB- (11)
2021-02-24 L2



R32928 UB- (10)
2021-02-24 L2



2021. 11. 10















