

Acct ID: 528158 MTL: 081W040001800 Date: **12-3-24** Appr: **Gene** Prop Class: 559 RMV Prop Class: 559  
 Situs: 11414 WALDO HILLS DR SE SALEM OR 97317 MaSaNh: 01 06 000 Unit: 22837 **Impd 24 12-16-24 Gene** Year: 2024  
 Last Date Appraised: 09/01/2016 Appraiser: CLINT LUKE Retag: **0** Tag info: 2025 - NEW CONSTRUCTION (Outbuilding)  
 Owner: SCHUDEL ENTERPRISES LLC Roll Type: R  
 Cycle **Tag** Sales Verification Other: \_\_\_\_\_ Inspection level: **1** 3 4 LCB TTO INSP AV: 320281  
 RMV Land: 909600 RMV Imp: 174070 RMV Total: 1083670 MAV: 216780 MSAV: 148061 SAV: 272034  
 Comment: **NOTHING YET ROAD 2026**

**Notations** **24-003605 AG EX 40x60**

RP/MS	Code	Description
MS	ZONED	FARM EFU ZONED
MS	ZONED	FARM EFU ZONED
MS	ZONED	FARM EFU ZONED

**OSDs** **Chris 2/7/25**

Count	Code	Description	RMV	Code Area	Exception
1	SAN	SA OSD - NO LANDSCAPE	30000	04580	0

**Land**

Site: 1	Code Area: 04580	Size: 144.29 Acres	Use Code: 005	Zone: REST	SAV Use: 011	Exception: 0
Class: 2HD	Value Source: Farm Use - EFU	Description: TWO HILL DRY			RMV: 793600	Exception: Y N
Adjustment(s): GSOIL		Fire Patrol:		Description:		
Comments: Liability year - 1974 / 21-22: PER #103 CHG LAND SCH FOR WOODLOT / 00-01; UPDATED MARKET VALUE, 4200188						
Site: 2	Code Area: 04580	Size: 9.00 Acres	Use Code: 005	Zone: REST	SAV Use: 011	Exception: 0
Class: 4HD	Value Source: Farm Use - EFU	Description: FOUR HILL DRY			RMV: 45000	Exception: Y N
Adjustment(s): GSOIL		Fire Patrol:		Description:		
Comments: Liability year - 1976 / 00-01; UPDATED MARKET VALUE, 4200188						
Site: 3	Code Area: 04580	Size: 1.00 Acres	Use Code: 005	Zone: REST	SAV Use: 011	Exception: 0
Class:	Value Source: Farm Homesite	Description:			RMV: 5000	Exception: Y N
Adjustment(s): GSOIL		Fire Patrol:		Description:		
Comments: Liability year - 2009 / 01-02: ADD TWO NEW HOMESITES AND OSD'S						
Site: 5	Code Area: 04580	Size: 7.20 Acres	Use Code: 005	Zone: REST	SAV Use: 011	Exception: 0
Class: WOOD	Value Source: Woodlot	Description: FARM WOODLOT			RMV: 36000	Exception: Y N
Adjustment(s): GSOIL		Fire Patrol:		Description:		
Comments: Liability year - 1987 / 17-18: PER #94, ADJUST SOIL CLASSES, ELIMINATE 3 HOMESITES WITH OSD'S / 09-10: HOMESITE PROJECT, CHG OSDA.RUR TO OSDN.RUR// 05-06: RECALC SETUP;#10 5/20/04 00 -01; UPDATED MARKET VALUE, 4200188						

**Improvements - Residence / Manufactured Structures**

Bldg: 1	Code Area: 04580	Stat Class: 467	Year Blt: 1977	Eff Year Blt: 1977	Sq.Ft: 1792	% Complete: 100
Desc: MANUF STRUCT, CLASS 6, 26' THROUGH 28' WIDE DOUBLE			Dimensions: 64x28		RMV: 46810	
Func Obsc: 100	Econ %: 100	Other %: 100	Exception: 0	Adjust:	Adjust RMV: 0	

**Floors**

Type	Class	Display Group	Floor Size	Beds	Baths	Yr Blt	Eff Yr Blt	Inventory	Exception
First Floor	6	Finished	1792	3	FB-2	1977	1977	BATH - 2, FP - 1, KIT, HVAC+, ROOF+, SKIRT	Y N

**Accessories**

Description	Class	Size SqFt	Eff Yr Blt	RMV	Quantity	Exception
DECK	6	112	1977	493	0	Y N
ROOF EXTENSION OR PATIO COVER	6	112	1977	650	0	Y N

Bldg: 1	Code Area: 04580	Stat Class: 457	Year Blt: 1987	Eff Year Blt: 1987	Sq.Ft: 1232	% Complete: 100
Desc: MANUF STRUCT, CLASS 5, 26' THROUGH 28' WIDE DOUBLE			Dimensions: 44x28		RMV: 32310	
Func Obsc: 100	Econ %: 100	Other %: 100	Exception: 0	Adjust:	Adjust RMV: 0	

**Floors**

Type	Class	Display Group	Floor Size	Beds	Baths	Yr Blt	Eff Yr Blt	Inventory	Exception
First Floor	5	Finished	1232	0	FB-2	1987	1987	BATH - 2, KIT-, HVAC+, ROOF+, SKIRT	Y N

**Accessories**

Description	Class	Size SqFt	Eff Yr Blt	RMV	Quantity	Exception
DECK	5	272	1987	1197	0	Y N
ROOF EXTENSION OR PATIO COVER	5	272	1987	1578	0	Y N

**Improvements - Accessory Buildings**

Bldg: 1 Code Area: 04580 Stat Class: 351 Year Blt: 1988 Eff Year Blt: 1988 Sq.Ft: 864 % Complete: 100  
 Desc: General Purpose Building (GB) Dimensions: 36x24 RMV: 4220  
 Func Obsc: 100 Econ %: 100 Other %: 100 Exception: 0 Adjust: Adjust RMV: 0

**Floors**

Type	Class	Display Group	Floor Size	Beds	Baths	Yr Blt	Eff Yr Blt	Inventory	
General Purpose Bldg	4	Finished	864	0	0	1988	1988	FAIR	Exception: Y N

NC

**Accessories**

Description	Class	Size SqFt	Eff Yr Blt	RMV	Quantity
No accessory data available					

Bldg: 2 Code Area: 04580 Stat Class: 342 Year Blt: 1993 Eff Year Blt: 1993 Sq.Ft: 6000 % Complete: 100  
 Desc: Metal Component Building (MC) Dimensions: 100x60 RMV: 78730  
 Func Obsc: 100 Econ %: 100 Other %: 100 Exception: 0 Adjust: Adjust RMV: 0

**Floors**

Type	Class	Display Group	Floor Size	Beds	Baths	Yr Blt	Eff Yr Blt	Inventory	
Metal Componet Bldg	6	Finished	6000	0	0	1993	1993	FAIR	Exception: Y N

NC

**Accessories**

Description	Class	Size SqFt	Eff Yr Blt	RMV	Quantity
No accessory data available					

Bldg: 3 Code Area: 04580 Stat Class: 355 Year Blt: 1993 Eff Year Blt: 1993 Sq.Ft: 1380 % Complete: 100  
 Desc: Lean-to Heavy (LTH) Dimensions: 46x30 RMV: 4470  
 Func Obsc: 100 Econ %: 100 Other %: 100 Exception: 0 Adjust: Adjust RMV: 0

**Floors**

Type	Class	Display Group	Floor Size	Beds	Baths	Yr Blt	Eff Yr Blt	Inventory	
Lean-to Heavy Duty	4	Finished	1380	0	0	1993	1993	FAIR	Exception: Y N

NC

**Accessories**

Description	Class	Size SqFt	Eff Yr Blt	RMV	Quantity
No accessory data available					

Bldg: 4 Code Area: 04580 Stat Class: 351 Year Blt: 1983 Eff Year Blt: 1983 Sq.Ft: 1024 % Complete: 100  
 Desc: General Purpose Building (GB) Dimensions: 32x32 RMV: 2580  
 Func Obsc: 100 Econ %: 100 Other %: 100 Exception: 0 Adjust: Adjust RMV: 0

**Floors**

Type	Class	Display Group	Floor Size	Beds	Baths	Yr Blt	Eff Yr Blt	Inventory	
General Purpose Bldg	4	Finished	1024	0	0	1983	1983		Exception: Y N

NC

**Accessories**

Description	Class	Size SqFt	Eff Yr Blt	RMV	Quantity
No accessory data available					

Bldg: 5 Code Area: 04580 Stat Class: 341 Year Blt: 1983 Eff Year Blt: 1983 Sq.Ft: 156 % Complete: 100  
 Desc: Multi Purpose Shed (MP) Dimensions: 13x12 RMV: 610  
 Func Obsc: 100 Econ %: 100 Other %: 100 Exception: 0 Adjust: Adjust RMV: 0

**Floors**

Type	Class	Display Group	Floor Size	Beds	Baths	Yr Blt	Eff Yr Blt	Inventory	
Multi-Purpose Bldg	4	Finished	156	0	0	1983	1983		Exception: Y N

NC

**Accessories**

Description	Class	Size SqFt	Eff Yr Blt	RMV	Quantity
No accessory data available					

Bldg: 6 Code Area: 04580 Stat Class: 341 Year Blt: 1983 Eff Year Blt: 1983 Sq.Ft: 144 % Complete: 100  
 Desc: Multi Purpose Shed (MP) Dimensions: 12x12 RMV: 730  
 Func Obsc: 100 Econ %: 100 Other %: 100 Exception: 0 Adjust: Adjust RMV: 0

**Floors**

Type	Class	Display Group	Floor Size	Beds	Baths	Yr Blt	Eff Yr Blt	Inventory	
Multi-Purpose Bldg	4	Finished	144	0	0	1983	1983	FAIR	Exception: Y N

NC

**Accessories**

Description	Class	Size SqFt	Eff Yr Blt	RMV	Quantity
No accessory data available					

Bldg: 7 Code Area: 04580 Stat Class: 351 Year Blt: 1983 Eff Year Blt: 1983 Sq.Ft: 784 % Complete: 100

Desc: General Purpose Building (GB)

Dimensions: 56x14

RMV: 3610

Func Obsc: 100

Econ %: 100

Other %: 100

Exception: 0

Adjust:

Adjust RMV: 0

NC

**Floors**

Type	Class	Display Group	Floor Size	Beds	Baths	Yr Blt	Eff Yr Blt	Inventory	Exception: Y N
General Purpose Bldg	5	Finished	784	0	0	1983	1983	FAIR	

**Accessories**

Description	Class	Size SqFt	Eff Yr Blt	RMV	Quantity
No accessory data available					

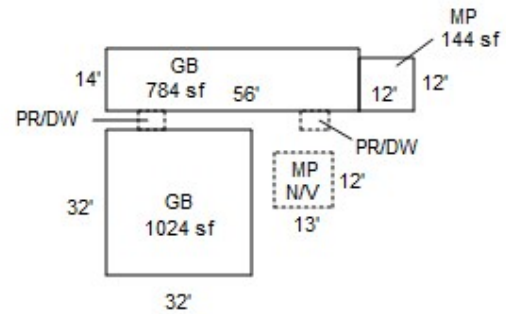

R28158  
081W04 01800  
SCALE=1:60



APPROX 2900' BETWEEN GBs AND MC/MS

