

Acct ID: 533719 MTL: 083W18C000300 Date: **12/3/24** Appr: **GRH** Prop Class: 551 RMV Prop Class: 451  
 Situs: 3941 VITAE SPRINGS RD S SALEM OR 97306 MaSaNh: 06 06 000 Unit: 30230 Year: 2024

Last Date Appraised: 09/20/2023 Appraiser: WENDY WILLIAMS Retag: Y N Tag info: 2025 - Tags/Permit (Outbuilding)  
 Owner: LAMONT-WITTE FAM TR & Roll Type: R  
 Cycle: **Tag** Sales Verification Other: \_\_\_\_\_ Inspection level: 1 2 3 4 LCB TTO INSP **owner plans to build AGEX 22-001989** AV: 525914  
 RMV Land: 686610 RMV Imp: 985403 RMV Total: 1672013 MAV: 488630 MSAV: 37284 SAV: 69352  
 Comment: 24-25: L2 09.20.23 WW  
 23-24: L2 12.2.22 GRH  
 LEVEL 2 10.1.20 SR94

**N/C**

**Notations**

**22-001989 50X30 AGEX FOR FLOWERS 23-24: NOT STARTED GRH 24-25: TTO PLANS TO BUILD IN 2024 WW**  
**FARM OK NURSERY AND LIVESTOCK**

RP/MS	Code	Description
RP	ZONED	FARM EFU ZONED

**OSDs**

Count	Code	Description	RMV	Code Area	Exception
1	SAG	SA OSD - GOOD	55000	92430	0
1	SPSA	SA SEPTIC	12000	92430	0

**Land**

Site: 1	Code Area: 92430	Size: 18.15 Acres	Use Code: 005	Zone: REST	SAV Use: 011	Exception: 0
Class: 4HD	Value Source: Farm Use - EFU	Description: FOUR HILL DRY	RMV: 414720	Exception: Y N		
Adjustment(s):	VWGR, GSOIL	Fire Patrol:	Description:			
Comments:	Liability year - 1981 / 19-20: PER #35 ADD OSD.SEPTIC FOR WORKER SHELTER// 2011-12: APPROVED FOR FARM USE 98-99 DISQ 16 ACRES, 99-2000: 8 AC DISQ FARM USE, THIS LAND SEGMENT INCLUDES THE HOUSE, 01-02; REAPPRAISAL, COMBINED LAND SEGMENTS, TOTAL 25 ACRES					
Site: 3	Code Area: 92430	Size: 1.00 Acres	Use Code: 005	Zone: REST	SAV Use: 011	Exception: 0
Class: 4HD	Value Source: Farm Homesite	Description: FOUR HILL DRY	RMV: 57850	Exception: Y N		
Adjustment(s):	VWGR, GSOIL	Fire Patrol:	Description:			
Comments:	Liability year - 2010 / 2011-12: ALL BUT 4.5 ACRES APPROVED FOR FARM USE, WAS NOT SA FROM 98-99 THRU 2010-11// 98-99 DISQ 16 ACRES, 99-2000: 8 AC DISQ FARM USE, THIS LAND SEGMENT INCLUDES THE HOUSE, 01-02; REAPPRAISAL, COMBINED LAND SEGMENTS, TOTAL 25 ACRES					
Site: 4	Code Area: 92430	Size: 5.85 Acres	Use Code: 005	Zone: REST	SAV Use: 011	Exception: 0
Class: 2HD	Value Source: Farm Use - EFU	Description: TWO HILL DRY	RMV: 147040	Exception: Y N		
Adjustment(s):	VWGR, GSOIL	Fire Patrol:	Description:			
Comments:	Liability year - 1981					

**Improvements - Residence / Manufactured Structures**

Bldg: 1	Code Area: 92430	Stat Class: 144 +	Year Blt: 1991	Eff Year Blt: 2001	Sq.Ft: 3952	% Complete: 100	
Desc:	Multi Story above grade with basement					Dimensions:	RMV: 654440
Func Obsc: 100	Econ %: 100	Other %: 100	Exception: 0	Adjust:	Adjust RMV: 0		

**Floors**

Type	Class	Display Group	Floor Size	Beds	Baths	Yr Blt	Eff Yr Blt	Inventory	Exception
First Floor	4 +	Finished	1424	1	FB-1/ HB-1	1991	2001	BATH - 1, BTH - 1, KIT+, HVAC+, FP - 2, ROOF	Y N
Second Floor	4 +	Finished	1424	3	FB-2	1991	2001	BATH - 2, ROOF, HVAC+	Y N
Basement	4 +	Finished	1104	0	0	1991	2001	HVAC+	Y N

**Accessories**

Description	Class	Size SqFt	Eff Yr Blt	RMV	Quantity
YARD IMPROVEMENTS GOOD	4	0	2001	33108	1
Exception: Y N					

Bldg: 2	Code Area: 92430	Stat Class: 148	Year Blt: 1991	Eff Year Blt: 1991	Sq.Ft: 0	% Complete: 100	
Desc:	Res other improvements					Dimensions:	RMV: 150670
Func Obsc: 100	Econ %: 100	Other %: 100	Exception: 0	Adjust:	Adjust RMV: 0		

**Floors**

Type	Class	Display Group	Floor Size	Beds	Baths	Yr Blt	Eff Yr Blt	Inventory	Exception
Garage Detached	4	Finished	864	0	0	1991	1991	ROOF	Y N
Garage Basement	4	Unfinished	864	0	0	1991	1991		Y N

**Accessories**

Description	Class	Size SqFt	Eff Yr Blt	RMV	Quantity
No accessory data available					

Bldg: 4	Code Area: 92430	Stat Class: 121	Year Blt: 2018	Eff Year Blt: 2018	Sq.Ft: 840	% Complete: 100
---------	------------------	-----------------	----------------	--------------------	------------	-----------------

Desc: One Story Only

Dimensions:

RMV: 169590

Func Obsc: 100

Econ %: 100

Other %: 100

Exception: 0

Adjust:

Adjust RMV: 0

**Floors**

Type	Class	Display Group	Floor Size	Beds	Baths	Yr Blt	Eff Yr Blt	Inventory	Exception: Y N
First Floor	2	Finished	840	0	FB-1	2018	2018	BATH - 1, KIT+, ROOF, HVAC	Y N
Garage Basement	2	Unfinished	840	0	0	2018	2018		Y N

**Accessories**

Description	Class	Size SqFt	Eff Yr Blt	RMV	Quantity	Exception: Y N
YARD IMPROVEMENTS AVERAGE	2	0	2018	9114	1	Y N

**Improvements - Accessory Buildings**

Bldg: 5 Code Area: 92430 Stat Class: 357 Year Blt: 2016 Eff Year Blt: 2016 Sq.Ft: 1840 % Complete: 100  
 Desc: Frost Control Dimensions: 46x10, 46x10, 46x10 RMV: 5348  
 Func Obsc: 100 Econ %: 100 Other %: 100 Exception: 0 Adjust: Adjust RMV: 0

**Floors**

Type	Class	Display Group	Floor Size	Beds	Baths	Yr Blt	Eff Yr Blt	Inventory	Exception: Y N
Frost Control	4	Finished	460	0	0	2016	2016		Y N
Frost Control	4	Finished	460	0	0	2019	2019		Y N
Frost Control	4	Finished	460	0	0	2019	2019		Y N
Frost Control	4	Finished	460	0	0	2016	2019		Y N

**Accessories**

Description	Class	Size SqFt	Eff Yr Blt	RMV	Quantity
No accessory data available					

Bldg: 6 Code Area: 92430 Stat Class: 357 Year Blt: 2022 Eff Year Blt: 2022 Sq.Ft: 800 % Complete: 100  
 Desc: Frost Control Dimensions: 50x16 RMV: 5355  
 Func Obsc: 100 Econ %: 100 Other %: 100 Exception: 0 Adjust: Adjust RMV: 0

**Floors**

Type	Class	Display Group	Floor Size	Beds	Baths	Yr Blt	Eff Yr Blt	Inventory	Exception: Y N
Frost Control	5	Finished	800	0	0	2022	2022		Y N

**Accessories**

Description	Class	Size SqFt	Eff Yr Blt	RMV	Quantity
No accessory data available					

# SKETCH/AREA TABLE ADDENDUM

## SUBJECT INFO

File No.: 533719 Parcel No.: 083W18C 00300  
 Property Address: 3941 VITAE SPRINGS RD S  
 City: SALEM County: MARION State: OR ZipCode: 97306  
 Owner:  
 Client: Client Address:  
 Appraiser Name: Inspection Date:

## SKETCH

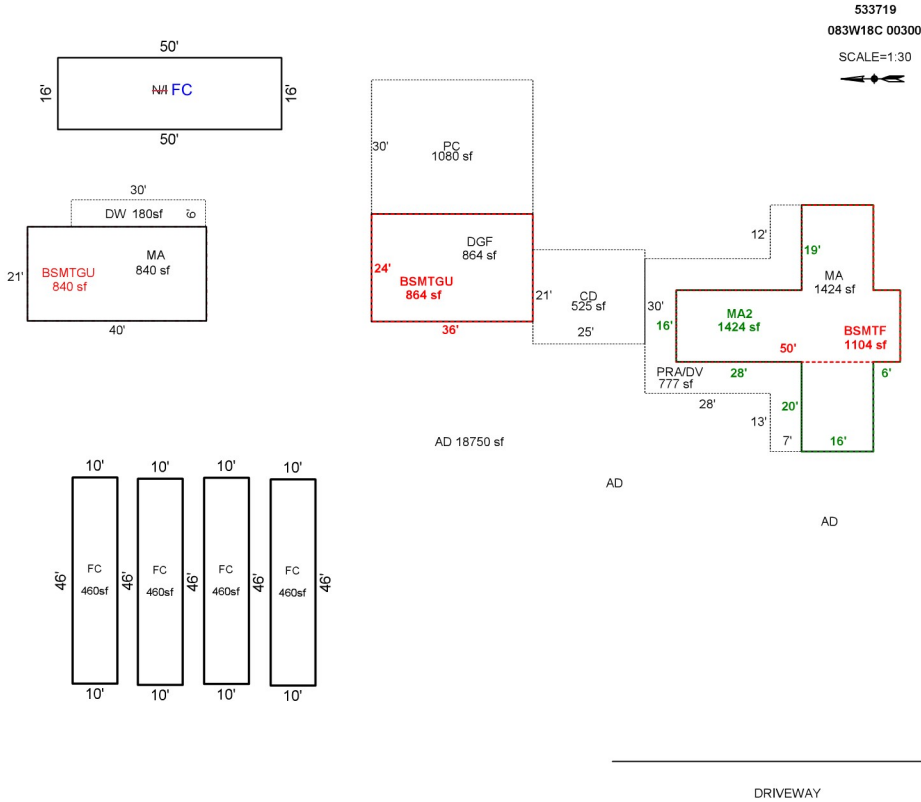

VITAE SPRINGS

Sketch by ApexSketch

### AREA CALCULATIONS SUMMARY

Code	Description	Factor	Net Size	Perimeter	Net Totals
GBA1	FC	1.0	460.0	112.0	
	FC	1.0	460.0	112.0	
	FC	1.0	460.0	112.0	
	FC	1.0	460.0	112.0	1840.0
GLA1	MA	1.0	1424.0	210.0	
	MA	1.0	840.0	122.0	2264.0
GLA2	MA2	1.0	1424.0	210.0	1424.0
BSMT	BSMTF	1.0	1104.0	170.0	
	BSMTGU	1.0	840.0	122.0	1944.0
GAR	DGF	1.0	864.0	120.0	
	BSMTGU	1.0	864.0	120.0	1728.0
P/P	PRA/DV	1.0	777.0	236.0	
	CD	1.0	525.0	92.0	
	PC	1.0	1080.0	132.0	
	DW	1.0	180.0	72.0	2562.0
	Net LIVABLE	cnt	3 (rounded)		3,688
	Net BUILDING	cnt	4 (rounded)		1,840

### COMMENT TABLE 1

Apex 5/14/2010 Jane  
 UPDATED BY JRONDEMA 3/11/19  
 UPD BY PHU 06.10.20  
 UPDATED BY WWILLIAMS 08.21.23

### COMMENT TABLE 2

12.19.19 NM #35: TAGS

9/20/23 WW

TAGS L2

*GRH 12/3/24 TAGS L2*

### COMMENT TABLE 3