

SKETCH/AREA TABLE ADDENDUM

SUBJECT INFO

File No.: 328425 Parcel No.: 091W10AA05200
 Property Address: 1683 MOUNTAIN DR
 City: STAYTON County: Marion State: OR ZipCode: 97383
 Owner:
 Client: Client Address:
 Appraiser Name: Inspection Date:

SKETCH

N/V

328425
091W10AA05200
SCALE: 1:30

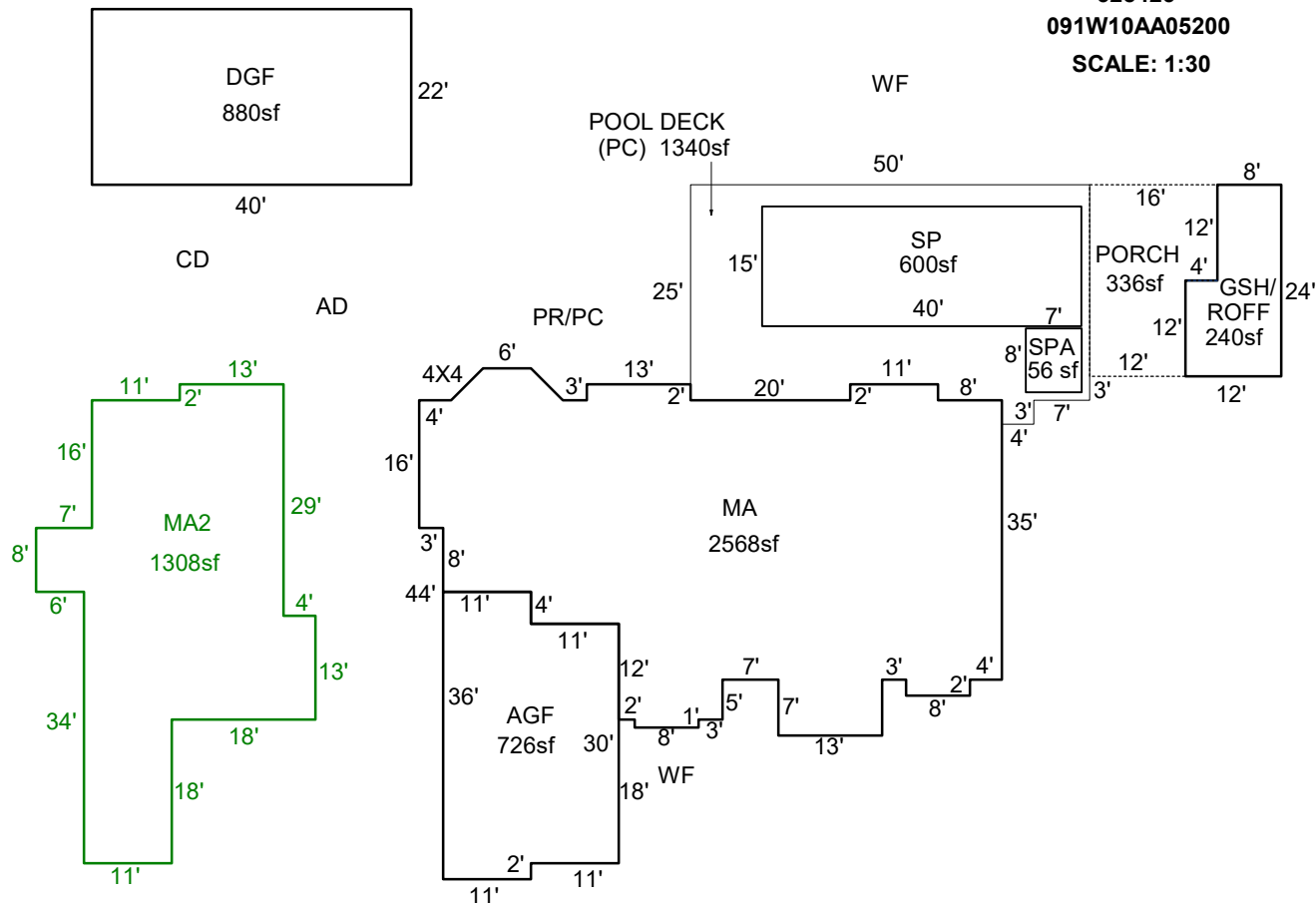

Sketch by ApexSketch

AREA CALCULATIONS SUMMARY

Code	Description	Factor	Net Size	Perimeter	Net Totals
GBA	GSH/	1.0	240.0	72.0	240.0
GLA1	MA	1.0	2568.0	257.3	2568.0
GLA2	MA2	1.0	1308.0	190.0	1308.0
GAR	AGF	1.0	726.0	116.0	
	DGF	1.0	880.0	124.0	1606.0
LAND	POOL DECK	1.0	1340.0	164.0	1340.0
OTH	SPA	1.0	56.0	30.0	
	SP	1.0	600.0	110.0	656.0

COMMENT TABLE 1

DRAWN BY SL
 UPDATED BY SH 4-6-09
 UPDATED BY RESTILL 6/29/16

COMMENT TABLE 2

COMMENT TABLE 3

Net LIVABLE cnt 2 (rounded) 3,876
 Net BUILDING cnt 1 (rounded) 240